

MAXIMIZING CBN GRINDING EFFICIENCY WITH A ROTARY DRESSING SYSTEM

Transitioning from the conventional grinding wheel to a ceramic-bonded cBN grinding wheel represents a significant **leap in the material removal rate** and **overall grinding performance**.

However, to fully capitalize these advantages, consideration must be given to the dressing process. cBN wheels feature advanced abrasive properties, demanding tailored dressing techniques for optimal outcomes. Achieving those requires **precise infeed control** and **minimizing dresser wear** to delicately remove only a few micrometers from the wheel during the dressing process.

This level of precision can only be achieved by implementing acoustic (TDC) or power-controlled monitoring of the dressing process with a rotary dresser.

Norton Winter provides complete dressing systems engineered for **outstanding strength** and **stability**. Our solutions ensure optimal **efficiency** and **cost-effectiveness**, delivering a precise and uniform grind for every use.



PACKAGE OFFERING

Package	Package #1	Package #2	Package #3	Package #4
Notes	ID Grinding <40mm		ID/Top Grinding >40mm, or Front Dressing	OD Grinding
Dresser	69014123247 6A9 (15mm)	66260218468 11V2 (16mm)	66260240897 6A9 (40mm)	69014194133 DDS (120mm)
Spindle	66260383986		60157661468	66260265349
Holder	66260265359		66260272550	66260265357
Cable / Plug	Comes already w/ 3m cable		66260303071 (4m)	66260265352 (7m)
Converter	60157667611		66260303070	66260270422
Analyzer (MotorView)	66260270423		66260268781	
Maintenance	60157693129			

Saint-Gobain Abrasives GmbH
 Birkenstraße 45 - 49
 50389 Wesseling
 Germany

Technology: 0049 177 5258 032
 Dresser: 0049 178 5258 692

For more information contact your local Norton Winter representative:
norton-winterspindle@saint-gobain.com

www.nortonabrasives.com
www.youtube.com/NortonAbrasiveEMEA

Norton Winter is a registered trademark of Saint-Gobain.
 Form # 4480

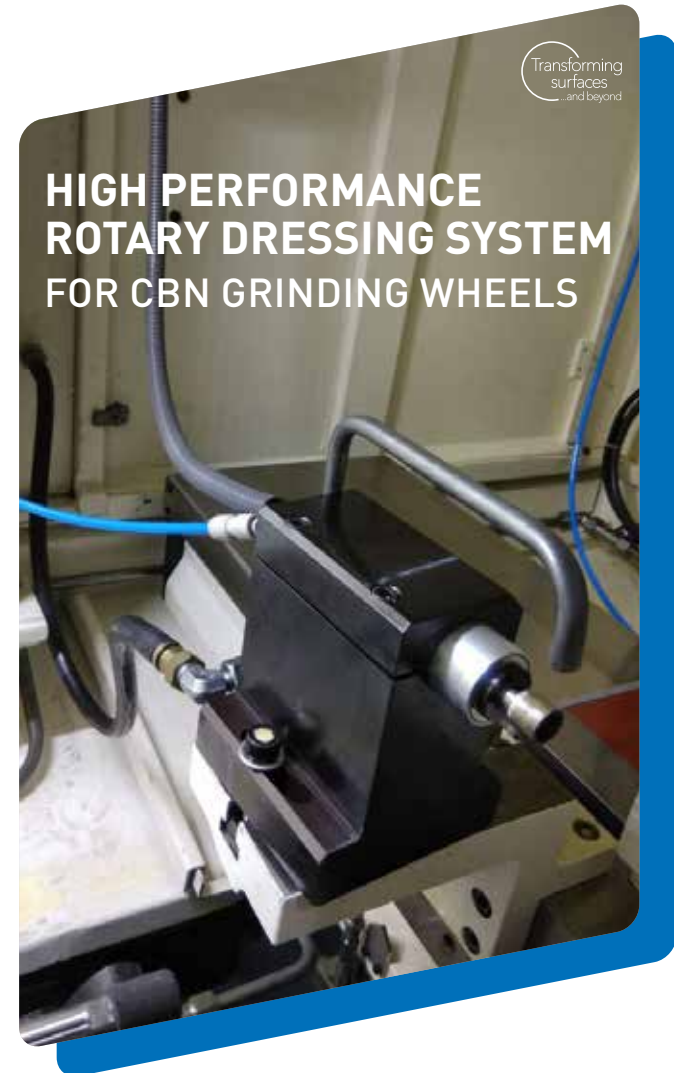

HIGH PERFORMANCE ROTARY DRESSING SYSTEM FOR CBN GRINDING WHEELS

Transforming surfaces and beyond



CASE STUDY 1

Bearing inner ring

Material	100Cr6
Operation	Internal grinding with oscillation
Coolant	Emulsion
Grinding/dressing speed (Vc/Vcd)	80m/s
Stock material	0,35-0,50mm
Wheel dimensions	30 x 12 x 10mm
Wheel specification	cBN B46
Surface finishing	Ra 0,5µm

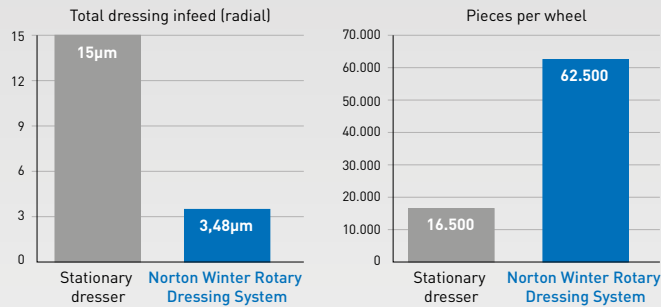

Benefits:

- Grinding wheel lifetime increased by 375%
- Grinding wheel cost reduction of 70%
- Lower power consumption and less heat introduced after dressing
- More stable process throughout the lifetime of the wheel

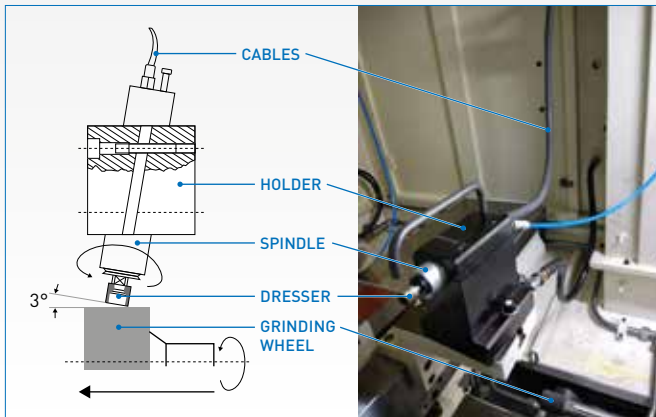

DRESSING SPINDLES AND SERVICE



- **Compact design**, allowing for seamless installation in nearly all standard grinding machines. Available in 3 distinct types to cater to **various needs** and **applications**.
- Fully compatible with existing converters.
- Alternatively, we offer complete systems that include converters and viewers and feature **user-friendly** menus for **easy navigation** and **data analysis** during installation.
- Comprehensive repair and maintenance services are available to ensure the **longevity of the spindles**, guaranteeing **sustained performance** over time.

Grinding with cBN grinding wheels

Dressed topography:	Worn topography:
• Grit protrusion low	• Grit protrusion high
• Active surface roughness low	• Active surface roughness high
• Grinding force high	• Grinding force low

Our application engineers are at your service, ready to conduct optimized dressing processes on your machine using the Saint-Gobain portable dressing system.



DRESSER TYPES

Form: 6A9/5 Dimensions: 15 x 13 x 7 mm Form: 11V2/5 Dimensions: 18 x 20 x 7 mm

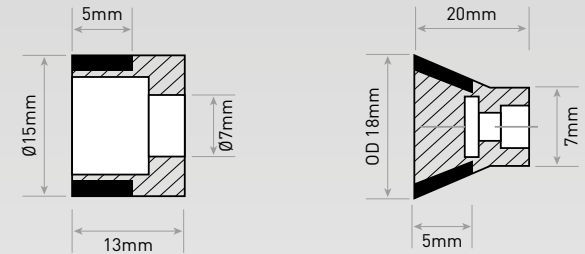

Form: 6A9/5 Dimensions: 40 x 16 x 20 mm

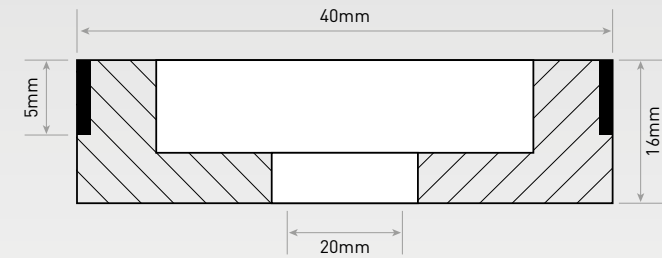

DDS Dimensions: 120 x 1 x 40 mm

