

OWNER'S MANUAL

HANDHELD ELECTRIC SAW

Model: CE414-350SS



Scan for a
Digital Copy of the
Owner's Manual

CAUTION: Read all safety and operating instructions before using this equipment.
This manual **MUST** accompany the equipment at all times.

REDEFINING
JOBSITE MUSCLE™

REV 07/23

Norton Clipper warrants all products manufactured by it against defects in workmanship or materials for a period of six (6) months from the date of the shipment to the customer.

To activate your warranty for all Norton Clipper products visit the **Product Registration** page on the website and register your machine.

The responsibility of Norton Clipper under this warranty is limited to replacement or repair of defective parts at a point designated by it, of such part as shall appear to us upon inspection at such point, to have been defective in material or workmanship, with expense for transportation borne by the customer.

In no event shall Norton Clipper be liable for consequential or incidental damages arising out of the failure of any product to operate properly.

Integral units such as **gasoline engines, electric motors, batteries, tires, transmissions, etc.**, are excluded from this warranty and are subject to the prime manufacturer's warranty. This warranty is in lieu of all other warranties, expressed or implied, and all such other warranties are hereby disclaimed.

Important: Before placing equipment in operation, record the following information:

UPC #: (starts with 701846-xxxxx)	MODEL #:
<input type="text"/>	<input type="text" value="CE414-350SS"/>
SERIAL #:	PURCHASE DATE:
<input type="text"/>	<input type="text"/>
PURCHASED FROM:	ADDRESS/CITY/STATE/ZIP:
<input type="text"/>	<input type="text"/>

Before using this equipment, make sure that the person using it has read and understands the instructions in this Owner's Manual.

⚠ WARNING ⚠

The engine exhaust from this product contains chemicals known to the State of California to cause cancer, birth defects or other reproductive harm.

Scan for
**PRODUCT REGISTRATION
AND INFORMATION**



nortonsga.us/ClipperReg

WARRANTY	1
SAFETY PRECAUTIONS HAZARD ICONS	3-4
SILICA AND DUST WARING.....	5
CALIFORINA PROPOSITION 65 MESSAGE.....	5
SAFETY WARINGS	6-13
PPE (Personal Protection Equipment) and Work Clothing.....	8-9
KICKBACK AND RELATED WARNINGS.....	12-13
GENERAL DESCRIPTION	14-17
SPECIFICATIONS.....	14
ITEMS INCLUDED WITH CE414-350SS	15
FUNCTIONAL FEATURES.....	15-16
POWER TRIGGER USAGE.....	17
ELECTRICAL SAFETY SYSTEM	17
ASSEMBLY	18-24
INSTALLING/REMOVING THE BLADE	18-19
ADJUSTING THE BLADE GUARD	20
WATER CONNECTIONS	20-21
ELECTRICAL CONNECTIOS.....	21-23
OPERATION	24-29
CHECK LIST	24
BLADES.....	25
PREMISSIBLE CUTTING AREA AND DANGER FROM KICKBACK/DRAWING ALONG	26
CUTTING TECHNIQUE.....	27-
CUTTING METALS.....	27
CUTTING CONCRETE/MASONRY MATERIALS	27
STEP CUTTING.....	28-29
MAINTENANCE AND SERVICE	30-33
CLEANING.....	30
MAINTENANCE SCHEDULE	31
REPLACING THE CARBON BRUSH.....	31-33
USING THE KICK STAND.....	33
TROUBLE SHOOTING.....	34
PARTS BREAKDOWN	35-43
MOTOR ASSEMBLY	36
BLADE GUARD ASSEMBLY	37
FORWARD HANDLE ASSEMBLY	38
GEAR BOX ASSEMBLY.....	39-40
REAR HANDLE ASSEMBLY	41
MAIN ASSEMBLY	42-43

Important warnings and pieces of advice are indicated on the machine with icons.

HAZARD ICONS



Danger! Failure to comply with the instructions could cause accidents with potentially life-threatening injuries



Caution! Failure to comply with the instructions could result in damage to the equipment or other material damage



Carefully read the operating instructions. This applies before taking the equipment into operation and before any cleaning maintenance, or assembly work.



Always wear the prescribed clothing.



Always wear sturdy shoes with good grip.



Wear safety gloves. This applies to all work with or on the equipment



Before use, put on helmet, ear defenders and a visor.



Switch off the motor!



Noise level $L_{WA} = 100$ dB(A).



Never continue work with damaged cutting discs.



Only use cutting discs approved for a speed of ≥ 3.900 rpm (min^{-1})



Attention: Kickback!

Notes in chap. **Kickback and Related Warnings** on page 12 must be observed under all circumstances!



Warning: Danger of fire electrical shock



Attention: Danger of fire from sparks.



Wear breathing protection.



Do not use circular saw blades.



Keep all guards in place when operating any piece of equipment



Keep Hands, Feet, Hair, and Clothing way from all rotating parts.









Never tamper with the governor components of settings to increase the maximum speed. Severe personal injury and damage to the motor or equipment can result if operated at speed above maximum. Always obey the maximum speed rating of blade.



Do Not Lift the Saw By The Cutting Head or Blade Guard

Important warnings and pieces of advice are indicated on the machine with icons.

SAFETY ICONS

 Read operator's instructions.	 Read OSHA and ANSI B7.1. Visit the industry safety page: www.safetyUAMA.org
 Eye protection must be worn.	 Ear protection must be worn.
 Protect your lungs against dust.	 Hand protection must be worn.
 Rotation direction of the blade.	  Pump On Pump Off

WARNING

DUST AND SILICA WARNING

Grinding/cutting/drilling of masonry, concrete, metal, and other materials can generate dust, mists and fumes containing chemicals known to cause serious or fatal injury or illness, such as respiratory disease, cancer, birth defects or other reproductive harm. If you are unfamiliar with the risks associated with the particular process and/or material being cut or the composition of the tool being used, review the material safety data sheet and/or consult your employer, the material manufacturer/supplier, governmental agencies such as OSHA and NIOSH and other sources on hazardous materials and make certain to comply with all product warnings and instructions for the safe and effective use of the material being cut. California and some other authorities, for instance, have published lists of substances known to cause cancer, reproductive toxicity, or other harmful effects.

Control dust, mist, and fumes at the source where possible. In this regard use good work practices and follow the recommendations of the manufacturer/supplier, OSHA/NIOSH, and occupational and trade associations. Water should be used for dust suppression when wet cutting is feasible. When the hazards from inhalation of dust, mists and fumes cannot be eliminated through engineering controls such as vacuum and/or water mist, the operator and any bystanders should always wear a respirator approved by NIOSH/MSHA for the material being cut.

CALIFORNIA PROPOSITION 65 MESSAGE

Some dust created by power sanding, sawing, grinding, drilling, and other construction activities contain chemicals known (to the State of California) to cause cancer, birth defects or other reproductive harm. Some examples of these chemicals are:

- Lead, from lead-based paints
- Crystalline silica, from bricks and cement and other masonry products
- Arsenic and chromium, from chemically treated lumber

For Addition Information Consult the Following Sources:

<http://www.osha.gov/dsg/topics/silicacrystalline/index.html>

<http://www.cdc.gov/niosh/consilic.html>

<http://oehha.ca.gov/prop65/law/P65law72003.html>

<http://www.dir.ca.gov/Title8/sub4.html>

Use Approved:



Eye Protection



Hearing Protection



**Respiratory
Protection**



Head Protection



The engine exhaust from this product contains chemicals known to the State of California to cause cancer, birth defects or other reproductive harm

108934

SAFETY WARNINGS

This power tool must only be used to cut or shorten metals (hot cut) and mineral materials, such as concrete, masonry products (brick, block, pavers), with a diamond blade cutting blade approved for the material and only for the working situation indicated in **Power Tool Usage**: chapter **Error! Reference source not found.**

This power tool can be used for indoor or outdoor work.

Use of this power tool for any other purpose, such as sawing of wood and to remove or grind off a material with the side surfaces of the blade is **forbidden** and is unsafe. Use of cutting tools, such as wood saw blades (which have a positive rake angle) or knives, must not be installed or used with this product.

USE only Norton Clipper Diamond Blades that are designed for use with Electric Handheld Saws and the material being cut. For assistance with the correct Diamond Blade for use with your CE414-350 contact customer service at 1-800-554-8003. Using low quality blades or misapplication of the blade for the material being cut can cause any electrical saw to draw higher amperage and will over time result in any electrical motor damage which is not covered under warranty.



WARNING *Read all safety warnings and all instructions. Failure to follow the warnings and instructions may result in electric shock, fire and/or severe injury.*

Save all warnings and instructions for future reference.

The term "power tool" in the warnings refers to your electric power saw.

1. Work area safety

- a. **Keep work area clean and well lit.** *Cluttered or dark areas invite accidents.*
- b. **Do not operate power tools in explosive atmospheres, such as in the presence of flammable liquids, gases, or dust.** *Power tools create sparks which may ignite the dust or fumes.*
- c. **Keep children and bystanders away while operating a power tool.** *Distractions can cause you to lose control.*

2. Electrical safety

- a. **Power tool plugs must match the outlet. Never modify the plug in any way. Do not use any adapter plugs with earthed (grounded) power tools.** *Unmodified plugs and matching outlets will reduce risk of electric shock.*
- b. **Avoid body contact with earthed (grounded) surfaces, such as pipes, radiators, ranges, and refrigerators.** *There is increased risk of electric shock if your body is earthed or grounded.*
- c. **Do not expose power tools to rain or wet conditions.** *Water entering a power tool will increase the risk of electric shock or equipment failure.*
- d. **Do not abuse the power cord. Never use the power cord for carrying, pulling or unplugging the power tool. Keep cord away from heat, oil, sharp edges, or moving parts.** *Damaged or entangled cords increase the risk of electric shock.*
- e. **While operating a power tool outdoors, use an extension cord suitable for outdoor use.** *Use of an extension cord suitable for outdoor use, and of the correct length and gauge reduces the risk of electric shock.*
- f. **If operating a power tool in a damp location is unavoidable, use a ground fault circuit interrupter (GFCI) protected supply.** *Use of an GFCI reduces the risk of electric shock. The CE414-350 is equipped with a GFCI ensure that it is operating properly before use.*

3. Personal safety

- a. **Stay alert, watch what you are doing and use common sense when operating a power tool. Do not use a power tool while you are tired or under the influence of drugs, alcohol, or**

medication. *A moment of inattention while operating power tools may result in serious personal injury.*

- b. **Use personal protective equipment. Always wear eye protection.** *Protective equipment such as dust mask, non-skid safety shoes, hard hat, or hearing protection used for appropriate conditions will reduce personal injuries.*
- c. **Prevent unintentional starting. Ensure the switch is in the off position before connecting to power source and/or battery pack, picking up or carrying the tool.** *Carrying power tools with your finger on the power switch or energising power tools that have the switch on invites accidents. Keep your finger off the power switch until you are ready to use the tool and all conditions for use are safe.*
- d. **Remove any adjusting key or wrench before turning the power tool on.** *A wrench or a key left attached to a rotating part of the power tool may result in personal injury.*
- e. **Do no overreach. Always keep proper footing and balance.** *This enables better control of the power tool in unexpected situations.*
- f. **Dress properly. Do not wear loose clothing or jewellery. Keep your hair, clothing and gloves away from moving parts.** *Loose clothes, jewellery or long hair can be caught in moving parts and may result in injury.*
- g. **If devices are provided for the connection of dust extraction and collection systems, ensure these are connected and properly used.** *Use of dust collection can reduce dust-related hazards.*

4. Power tool use and care

- a. **Do not force the power tool. Use the correct power tool for your application.** *The correct power tool will do the job better and safer at the rate for which it was designed.*
- b. **Do not use the power tool if the power switch does not turn it on and off.** *Any power tool that cannot be controlled with the power switch is dangerous and must be repaired before use.*
- c. **Disconnect the power plug from the power source and/or the battery pack from the power tool before making any adjustments, changing accessories, or storing power tools.** *Such preventative safety measures reduce the risk of starting the power tool accidentally.*
- d. **Store unused power tools out of the reach of children and do not allow persons unfamiliar with the power tool or these instructions to operate the power tool.** *Power tools are dangerous in the hands of untrained users.*
- e. **Maintain power tools. Check for misalignment or binding of moving parts, breakage of parts and any other condition that may affect the power tool's operation. If damaged, have the power tool repaired before use.** *Many accidents are caused by poorly maintained power tools.*
- f. **Keep cutting tools sharp and clean.** *Properly maintained cutting tools with sharp cutting edges are less likely to bind and are easier to control.*
- g. **Use power tool, accessories, and tool bits etc. in accordance with these instructions, taking into account the working conditions and the work to be performed.** *Use of the power tool for operations different from these intended could result in hazardous situation.*

5. Service

- a. **Have your power tool serviced by a qualified repair person using only identical replacement parts.** *This ensure the safety of the power tool is maintained.*



You Are Responsible for Your Safety!!!

1. Before mounting any blade on the saw, the blade should be inspected for any damage which might have occurred during shipment, handling, or previous use.
2. The blade collars and arbors should be cleaned and examined for damage before mounting the blade.
3. The blade must be properly fitted over the arbor with the relief side of the collars facing the blade.
4. The blade shaft nut must be tightened securely against the outside blade shaft collar.
5. The blade must be operated within the specified maximum operating speed listed on the blade.
6. Wet cut whenever possible.
7. The blade guard must be in place with the nose guard down and locked when the saw is running.
8. The operator should wear safety glasses and any other appropriate safety equipment.
9. When starting the saw, the operator should stand away and to the side of the blade.
10. If for any reason the saw should stall in the cut, remove the material from the blade. Check the outside blade shaft collar and nut for tightness. Inspect the blade for damage before restarting the saw. Use caution when resuming a cut. Be certain that the blade is in alignment with the previous cut.
11. Do not force the blade into the cut by pushing the material into the blade too fast.



You Are Responsible For Your Safety!!!

PPE (Personal Protection Equipment) and Work Clothing

To prevent injuries, please make sure that you wear the proper approved clothing and protective equipment.



Clothes should be tight-fitting (no labels), but not hindering. When performing any work, wear a working suit of firm materials with sufficient flame resistance so that cannot catch fire by sparks flying (materials of leather, cotton after flame-inhibiting treatment or heavy close-meshed linen fabrics).

Check the information in the work clothes and ensure that no flammable materials and no easily melting materials like polyester or nylon are contained in the clothes. The working clothes must never be contaminated with flammable substances such as petrol or similar.

Never wear scarves, ties, jewelry, or other clothes that may get caught in the cutting disc or blade, or objects in the environment, or the power tool. Tie back long hair and secure it under a helmet.



Wear a protective helmet during any work. Use personal hearing protection.

Eye/face protection is mandatory pursuant to ANSI Z 87.1.



Wear approved safety shoes with steel toes and a good grip.



Wear protective gloves with non-slip palms.



Use approved respiratory protection meeting a minimum of N95 rating for dry cutting as protection from dust.

Transport



- Before carrying or moving the power tool (even for short distances), always switch off the motor, wait until the cutting disc has stopped rotating, and disconnect the power supply. Carry the power tool by the top handle and have the cutting blade facing down and to the rear. Never carry the power tool by the power cable.
- Never drag or pull the power tool by the power cable.
- Never carry or transport the power tool with the cutting disc or blade turning.

Advice: We recommend that you keep the original packaging to protect the equipment against transport damage in case you ever need to ship it or transport it.

Before Use



- Before assembly, cleaning, maintenance, and repair, always turn off the motor.
- Wear protective gloves for any work.
- The power tool requires regular maintenance. Only perform such maintenance and repair work on your own that are described in these operating instructions and that you consider yourself skilled at performing. Any other work must only be performed by specialist workshops authorized by the manufacturer.
- Only perform repairs with original spare parts.
- Danger of accident and injury! Never modify the power tool, as this may impair safety!

Before Start Up



- Before start-up, check the entire power tool for operationally safe conditions. In addition to the notes in the operating and maintenance notes (□ chap. 8), check the following items:
- GFCI switch must be reset before starting.
- In case of irregularities, visible damage, improper settings or limited function, the power tool must not be started. In such cases, have the power tool inspected by specialist workshops authorized by the manufacturer.

When Starting



- Only use the power tool if it is in completely assembled condition.
- Hold the tool securely and firmly when starting.
- Always start up on level ground and securely hold the power tool.
- Perform the starting process as described in chap. 6 on page 24.

Electrical Safety



- Keep at least 9.8 feet (3 meters) distance from any flammable material when operating this machine.
- Plug the power tool into the appropriate matching grounded outlet with the matching voltage (115v/60Hz/1). Do not attempt to adapt the plug head to use with a non-matching outlet.
- Avoid contact with earthed or grounded surfaces to avoid electric shock.
- Keep the power tool away from water. Do not leave the machine outside where it may be rained upon. Water exposure will increase the risk of electric shock.
- Do not pressure wash or wash the machine. Water exposure will increase the risk of electric shock.
- Do not carry the tool by the power cord. Do not use the machine if the cord is damaged. A damaged cord will increase the risk of electric shock. If damaged have the cord repaired by a certified technician immediately.
- Use extension cables with the correct length and gauge. Refer to section 4.1 and view the recommended extension cable chart if not known what type of extension cable to use.
- Keep extension cables unrolled during use to maintain the power tool's efficiency.
- Only use undamaged extension cables to reduce the risk of electric shock.
- When operating the power tool, make sure the power cable is always behind you.
- Do not use the power tool if the power trigger does not turn on the motor. A malfunctioning power switch should be repaired by a certified technician.

During Work



In addition to the safety provisions already listed, the following safety provisions also apply when working with the motor device:

- Secure the workplace against accidental access by third parties, ex. with warning signs. Only persons involved and wearing adequate protective equipment and clothes must be

present within 30 meters [approx. 30 yards] around the working area.

- Check the site of deployment for possible dangers.
 - Spark formation during cutting means that work must never be performed close to potentially explosive due to shortages.
 - No electrical lines, water or gas pipes or flammable substances must be placed in the area to be cut.
 - Objects that may fall off or topple over during work must be secured or removed from the working environment first.
 - Prepare the workplace so that secure operator mobility is possible.
- The work piece to be cut must be free of foreign bodies such as screws, nails or stones.
- When working in residential areas, observe the noise protection provisions.
- Work carefully, considerately, and calmly and do not endanger others.
 - Ensure good sight and light conditions.
 - Always remain within calling distance of other persons who may administer first aid in emergencies.
 - Schedule work breaks.
 - Be attentive towards possible danger sources and take the corresponding preventive measures. Consider that use of hearing protection limits perception of sounds. Signal sounds, calls, etc. that announce danger may also be missed.
 - Observe tripping dangers and obstacles. Never work on unstable grounds.
 - Always hold the power tool with both hands and always ensure a safe and firm stance.
 - Never cut standing on a ladder.
 - Guide the power tool so that no body part is located in the extended swivel range of the cut-off wheel.
 - Do not hold the work piece in your hand and bring it into contact with the wheel.
 - Bring the rotating cut-off wheel into contact to the work piece.
 - Never touch the floor or other objects with the cut-off wheel running.
 - Do not use the power tool to level off and shovel away objects.
- Switch off the motor when the power tool starts to behave noticeably differently.

Kickback and Related Warnings



Kickback is a sudden reaction to a pinched or snagged rotating wheel. Pinching or snagging causes rapid stalling of the rotating wheel which in turn causes the uncontrolled power tool to be forced in the direction opposite of the wheel's rotation at the point of the binding.

For example, if an abrasive wheel is snagged or pinched by the workpiece, the edge of the wheel that is entering into the pinch point can dig into the surface of the material causing the wheel to climb out or kick out. The wheel may either jump toward or away from the operator, depending on direction of the wheel's movement at the point of pinching. Abrasive wheels may also break under these conditions.

WARNING: Avoid cutting in the upper quadrant of the blade, especially when beginning the cut. This area is highly likely to lead to kickback.

WARNING: When cutting plastics, do not allow the plastic to melt. If the plastic melts, it can stick to the blade, leading to kickback.

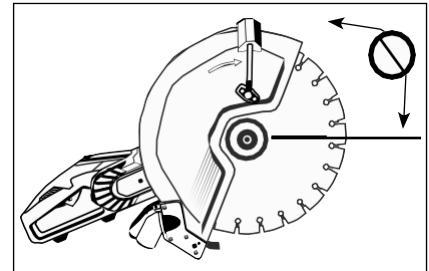

Kickback is the result of power tool misuse and/or incorrect operating procedures or conditions and can be avoided by taking proper precautions as given below:

- Maintain a firm grip on the power tool and position your body and arm to allow you to resist kickback forces. Always use auxiliary handle, if provided, for maximum control over kickback or torque reaction during start-up. The operator can control torque reactions or kickback forces if proper precautions are taken.
- Never place your hand near the rotating accessory. Accessory may kickback over your hand.
- Do not position your body in line with the rotating wheel. Kickback will propel the tool in direction opposite to the wheel's movement at the point of snagging.
- Use special care when working corners, sharp edges etc. Avoid bouncing and snagging the accessory. Corners, sharp edges or bouncing tend to snag the rotating accessory and cause loss of control or kickback.
- Do not attach a saw chain, woodcarving blade, segmented diamond wheel with a peripheral gap greater than 10 mm or toothed saw blade. Such blades create frequent kickback and loss of control.
- Do not "jam" the wheel or apply excessive pressure. Do not attempt to make an excessive depth of cut. Overstressing the wheel increases the loading and susceptibility to twisting or binding of the wheel in the cut and the possibility of kickback or wheel breakage.
- When wheel is binding or when interrupting a cut for any reason, switch off the power tool and hold the power tool motionless until the wheel comes to a complete stop. Never attempt to remove the wheel from the cut while the wheel is in motion otherwise kickback may occur. Investigate and take corrective action to eliminate the cause of wheel binding.
- Do not restart the cutting operation in the workpiece. Let the wheel reach full speed and carefully

re-enter the cut. The wheel may bind, walk up or kickback if the power tool is restarted in the workpiece.

- Support panels or any oversized workpiece to minimize the risk of wheel pinching and kickback. Large workpieces tend to sag under their own weight. Supports must be placed under the workpiece near the line of cut and near the edge of the workpiece on both sides of the wheel. Use extra caution when making a “pocket cut” into existing walls or other blind areas. The protruding wheel may cut gas or water pipes, electrical wiring

TECHNICAL DATE

Model	C414-350	
Motor	Brush Motor	
Horsepower	4.1	
Watts	3,100	
Power	Amp	15
Voltage	V	115
Hertz	hz	60
GFCI	YES	
IC Soft Start	YES	
Thermal Overload Protection	YES	
Electronic Clutch	YES	
LED Indicator Lights	YES	
Cord Length w/GFCI	ft / m	9.8' (3m)
Spindle Diameter	in / mm	0.787 (20mm)
Spindle Diameter with Bushing	in / mm	1 (25.4)
Blade Shaft Speed	rpm	3,900
Blade Flange Diameter	in / mm	4 (100)
Sound of Motor Without Cutting Blade	dB	100 dB
Maximum Blade Diameter	in / mm	14 (350)
Cutting Depth w/14" Diamond Blade	in / mm	5 (125)
Dimensions	Height x Width x Length in / mm	11.1 (282) h x 11.3 (286) w x 28.7 (730) l
Weight without cutting diamond blade	lb / kg	22.4 (10.2)

Recommended Extension Cables	
12 AWG	50'
10 AWG	75'
8 AWG	100'

 **Use Only Genuine Norton Diamond Blades**

ITEMS INCLUDED WITH CE414-350SS

- Machine CE414-350
- Tool: Universal Wrench
- Air Filter (Pack of 6)
- Operating instructions

FUNCTIONAL FEATURES

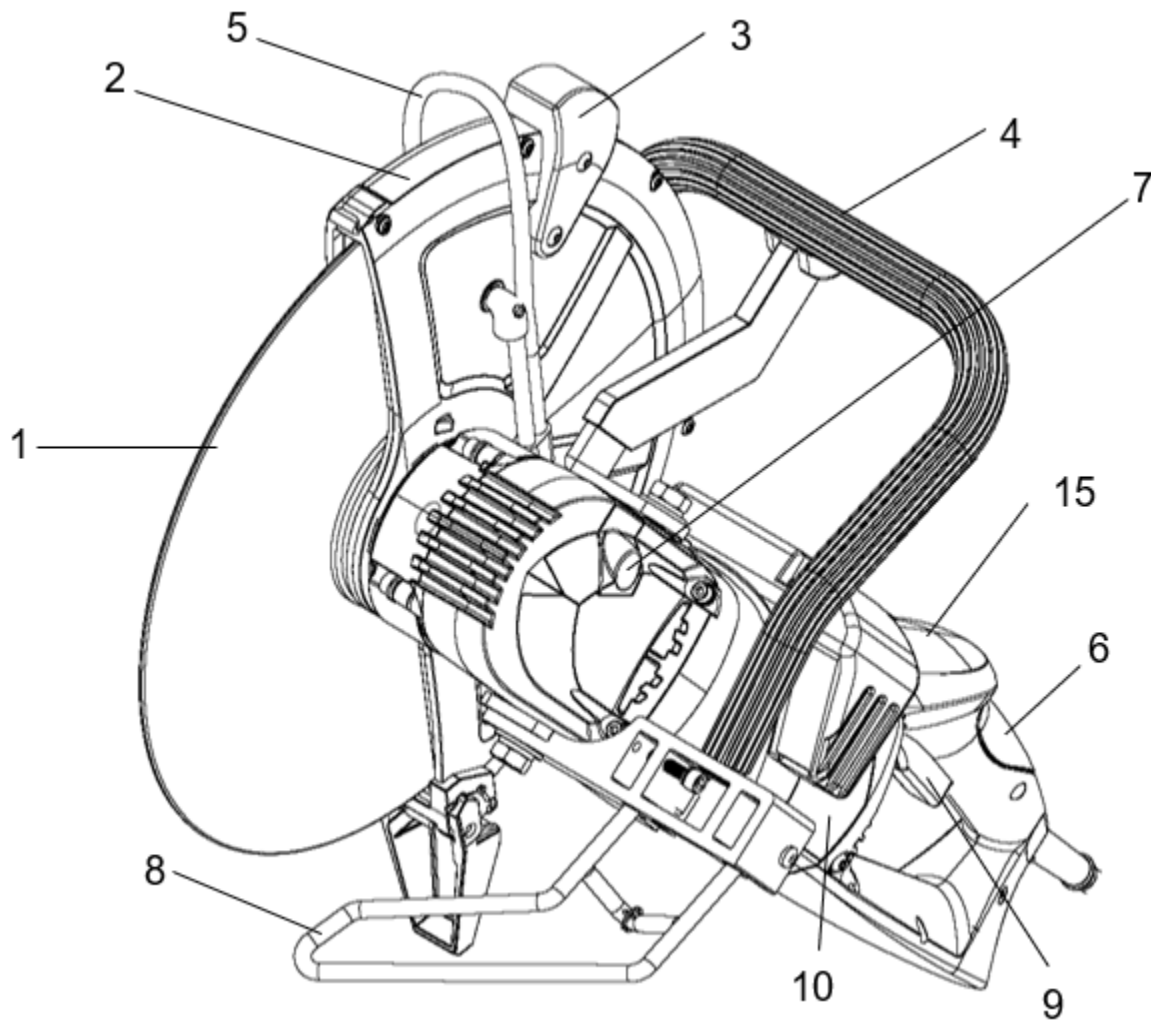

CE414-350SS Operator's Front Left

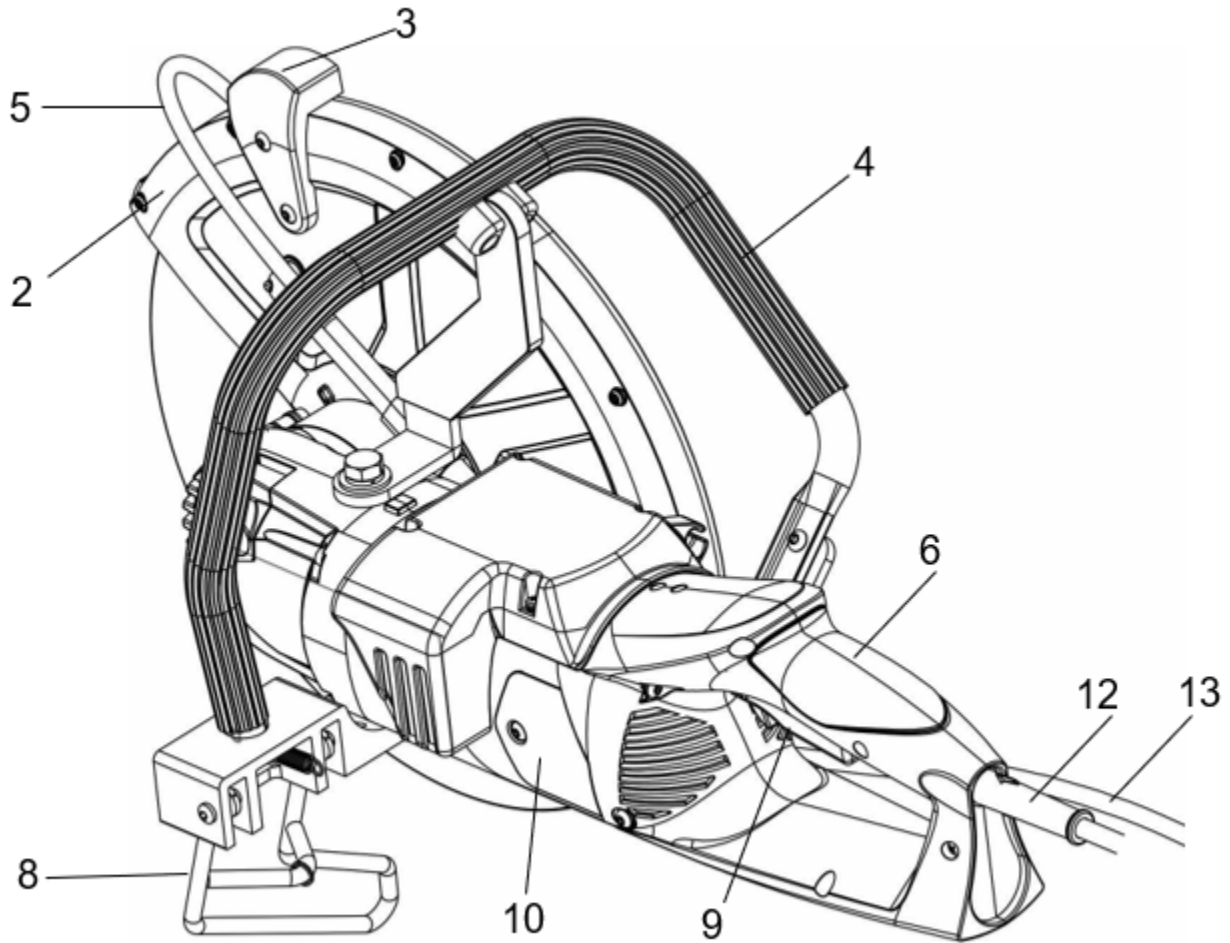

CE414-350SS Operator's Rear Left

1. Cutting Blade	9. Trigger Assemble
2. Blade Guard	10. Carbon Brush Cover
3. Grip for Blade Guard Adjustment	11. Blade Shaft Screw
4. Top Handle	12. Power Cable
5. Water Hose	13. Water Hose to Coupling
6. Rear Handle	14. Water Coupling Connection (Wet Cutting)
7. Spindle Lock Button	15. Power and Overload Indicator
8. Kick Stand	16. Power Trigger Lock

POWER TRIGGER USAGE

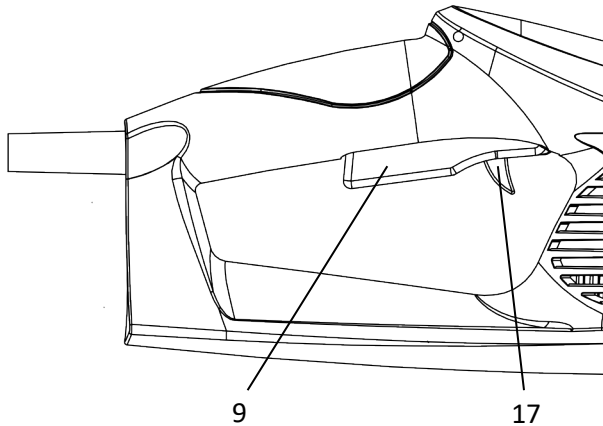

Testing functionality of power trigger

- To test the power trigger, connect the machine to the correct power supply, grasp the handle to position your fingers next to the power trigger. Using the index finger and push to disengage the lock trigger (17), shown on the left. With the lock disengaged, pull the power trigger up (9) and then release. The motor should turn on and then off when the trigger is released.
- If the motor does not turn off or blade does not stop spinning, have the switch assembly serviced immediately by a certified technician. In the meantime, discontinue use of the power saw.
- The power trigger lock should also be tested. This time pull the power trigger only (9). If the motor turns on, then the lock trigger is damaged and needs to be serviced. Have the switch assembly serviced by a certified technician. In the meantime, discontinue use of the power saw.

ELECTRICAL SAFETY SYSTEM

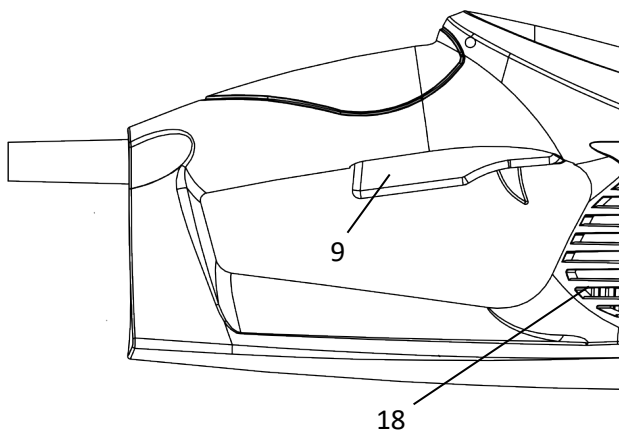

The heavy-duty power switch in the power saw is coupled with two safety features. A soft start system (18) which prevents unintentional power trips during start-up, and overloads. Source of overload can be from user applying too much cutting force or from the blade jamming. The overloaded state must be reset by releasing the power trigger (a) and then depressing it once again to return power to the motor. Before performing the reset, the source of overload should be corrected.

INSTALLING/REMOVING THE BLADE



Make Sure that the machine is OFF and unplugged before installing or removing the blade. **WARNING:** Do not attempt to mount a blade which does not match the Arbor size, blade guard diameter, or is not rated for use with the machine and product to be cut. Do not attempt to mount a blade which does not match the mounting hardware of the machine. Incorrect mounting will lead to eccentric running and vibrations which will be uncontrollable. The cutting discs used must correspond to the specifications from Blades section on page 25. The power tool uses a 20mm spindle is paired with an adapter blade adapter for use with 1 inch (25.4mm) bore cuttings blade. The components are assembled as shown below, along with the universal wrench (e) included with the power tool to remove the blade bolt (d).

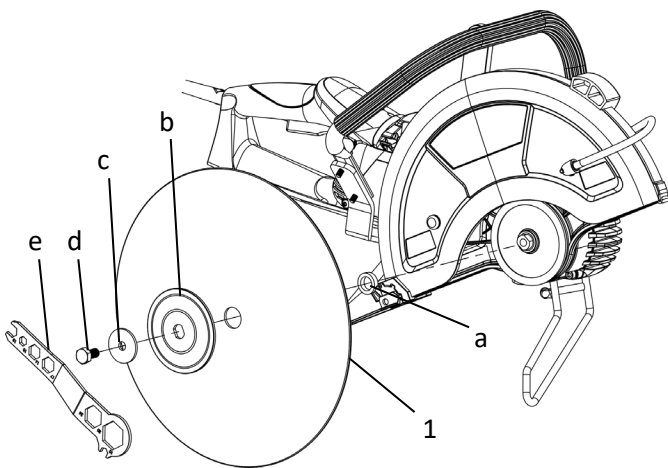

- a. 1"/20mm Adapter
 - b. Outer Flange (Lose Collar)
 - c. Large Washer
 - d. Blade Shaft Bolt (Left Hand Thread)
 - e. Universal Wrench
1. 14" Norton Clipper Diamond Blade

- For blade installation, the power tool must be put securely on the ground and unplugged. With the power tool handle facing you place left arm on the power tool body and use the correlating hand to press the spindle lock button (7) shown below. With the free hand use the universal wrench (e) to turn the blade bolt (d) clockwise, or away from you (NOTE: The Blade Shaft Bolt has a LEFT HAND THREAD, overtightening in the incorrect direction will lead to the Blade Shaft Bolt breaking and is not covered under any warranty. Apply slight downward force from the left arm onto the motor body to keep the tool from moving, if it should:

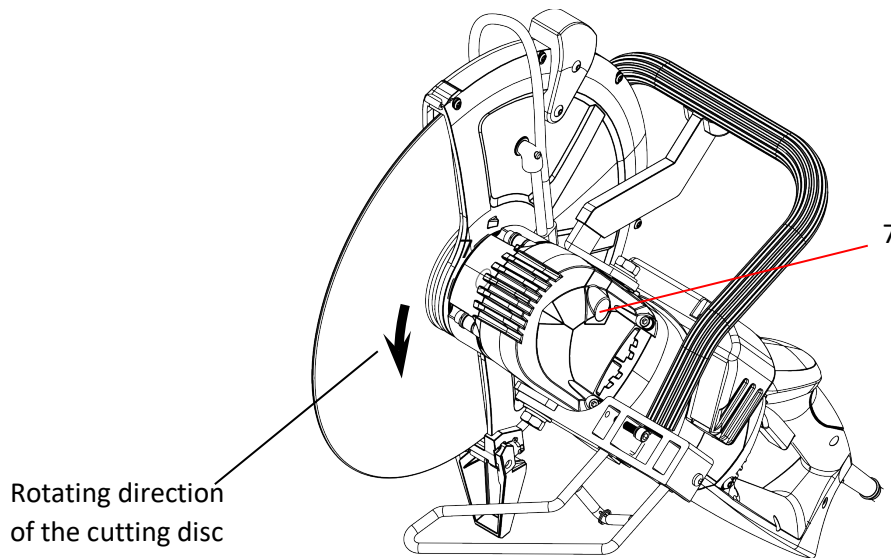

- Remove the blade bolt (d), its washer (c) and outer flange (b). Install the cutting disc (1), and make sure the bore of the disc slides onto the adapter (a) all the way. Also locate the rotational direction of the disk and match it with the diagram above's note. If you are facing the blade guard, the blade rotational direction is Clockwise. Installing the diamond blade with the incorrect direction of rotation will result in the blade not cutting properly and rounding of the diamonds.
- Once the diamond blade (1) is properly seated, reinstall the outer flange (b), washer (d) and blade bolt. Press the spindle lock button (7) again and this time use the universal wrench (e) to turn the blade bolt counter-clockwise until tight.

ADJUSTING THE BLADE GUARD

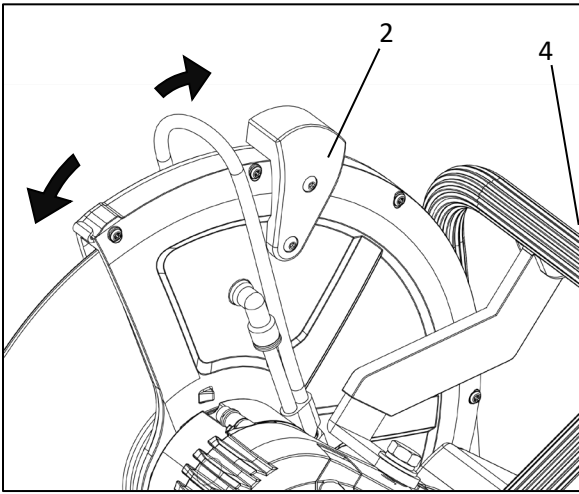

Ensure that the machine is OFF, not running, and remove the Spark Plug when making any adjustment. The blade guard shown on the left can be swivelled forward and backward in a limited area.

For adjustment of the blade guard, the power tool must be securely on the ground with the power supply disconnected. Hold the tool securely by the top handle (**Error! Reference source not found.**) with the one hand and push it firmly onto the ground. With the other hand at the handle for the blade guard adjustment (2), swivel the Blade Guard accordingly.

To keep sparks and particles from being thrown at the operator, the blade guard should always be swivelled forward as far as the working situation permits.

WATER CONNECTION

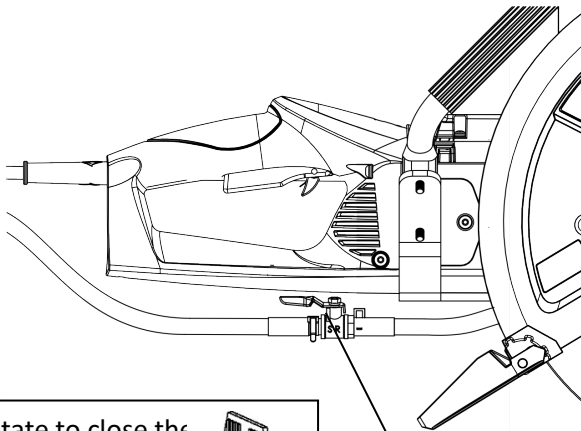

Rotate to close the valve (valve lever across)

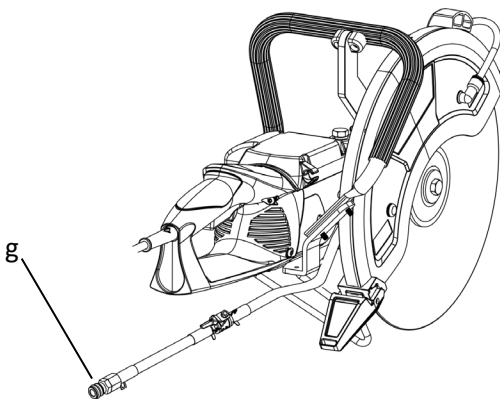

Lots of fine dust occurs when cutting mineral-based materials. We recommend using the water connection when using diamond blades suitable for the material and rated for wet cutting. When cutting with the water, visibility of the material is improved, and blade life can increase due to the cooling effect of the water.

Before Wet Cutting:

- Connect suitable water line (maximum 80 PSI) or suitable pressure tank to the coupling connection (g).
- Operate the valve lever (f) to open or close the water supply to the desired flow rate.

After Wet Cutting:

- Close the water supply, i.e., put the valve lever perpendicular to the valve body.
- Let the cutting disc run at high speed for another approx. 30 seconds to completely remove the water from the system.

Water Connection

Water is a basic requirement for diamond sawing with wet-type diamond blades. The water serves as a coolant to avoid the working surface of the diamond segments from overheating. When the diamond bit becomes overheated, both the bond matrix and even the diamonds break down, thus destroying the blade. Besides cooling, water also keeps down dust and flushes away abrasive particles.

Use a water collector with a wet vacuum to collect cooling water if nearby objects could be damaged by water. The water feed system is built into the machine. To connect with the water supply, first pull the quick-release collar to remove the female side of the water coupling. Then unscrew the nut and engage the coupling to the water hose. Now reconnect the water coupling to the male water feed valve. Press it until it clicks. The water flow is controlled by the water feed valve. The water to the blade may be finely adjusted to the required amount and no more.

NOTE: Contaminants in the water supply can easily plug up the fine water nozzles in the blade guard. Ensure that the supply water is clean. If you find that there is no water flow to the blade, then clean out the water feed system on the machine.

WARNING: Always use the GFCI (PRCD) when operating with water.

Never allow water to enter the motor or switch area as it could lead to an electric shock.

Inspect hoses and other critical parts which could deteriorate.

The maximum water pressure should not exceed 70 psi (4 bar).

Check all connections of the water feed system to ensure there are no leaks

ELECTRICAL CONNECTION

Electrical Power:

Important Before connecting the motor leads to the power supply, be sure that the voltage, cycles, and phase shown on the nameplate of the motor correspond to the available power supply. The CE414-350SS is only suitable for use with 115v/60 Hz/1 phase power and 20A circuit is recommended (using a 15A circuit can result in tripping the power source circuit breaker due to: pushing the tool too hard, using the incorrect blade for the material being cut, and/or from using too long and/or thin of gauge extension cord. Connecting to 230v may damage the motor and is not covered under warranty. In addition, using the product on low voltage circuits due to low voltage or too long or thin of extension cords will overheat and damage any electrical motor and is not covered under warranty. The CE414-350 can safely run on voltage from as low as 108v but 115-120v is recommended at all times. Ensure that the product is properly grounded per NEC (National Electrical Code), State, and Local codes and laws. If, after proper electrical connections are made, the motor will not run, press the reset button to the overload protector switch.



Failure to run the motor on the proper voltage will damage the motor and is not covered under warranty. Damage due to improperly wired motors is not covered under warranty.

Power Connections and Extension Cords

Extension cord with an electrical plug with **20-amp minimum capacity** should be used. Connecting wires should be as short as possible, one piece of good condition, and suitable for outdoor usage. In no case should the connecting wires be longer than shown in the following table:

Recommended Extension Cables	
12 AWG	50'
10 AWG	75'

Caution-When wires that are too small gauge or too long are used, loss of power, overheating, or damage to the motor will result.

- In the event of a malfunction or breakdown, grounding provides a path of least resistance for electric current to reduce the risk of electric shock. This tool is equipped with an electric cord having an equipment-grounding conductor and a grounding plug. The plug must be plugged into a matching outlet that is properly installed and grounded in accordance with all local codes and ordinances.
- Do not modify plug - if not fits the outlet, have the proper outlet installed by a qualified electrician.
- Improper connection of the equipment-grounding conductor can result in a risk of electric shock. The conductor with insulation having an outer surface that is green with or without yellow stripes is the equipment-grounding conductor. If repair or replacement of the electric cord or plug is necessary, do not connect the equipment-grounding conductor to a live terminal.
- Check with qualified electrician or service personnel if the grounding instructions are not completely understood, or if in doubt as to whether the tool is properly grounded.
- Use only 3-wire extension cords that have 3-prong grounding plugs and 3 pole receptacles that accept the tool's plug.
- Repair or replace damaged or worn cord immediately.
- Grounded, cord-connection is intended for a supply circuit having a nominal rating less than 150 V.
- This tool is intended for use on a circuit that has an outlet that looks like the one illustrated in Sketch
- A. The tool has a grounding plug that looks like the plug illustrated in Sketch A within **Figure: Outlet/Plug Grounding** below. A temporary adapter, which looks like the adapter illustrated in Sketches B and C, may be used to connect this plug to a 2-pole receptacle as shown in Sketch B if a properly grounded outlet is not available. The temporary adapter should be used only until a properly grounded outlet can be installed by a qualified electrician. The green-colored rigid ear, lug, and the like, extending from the adapter must be connected to a permanent ground such as a properly grounded outlet box.

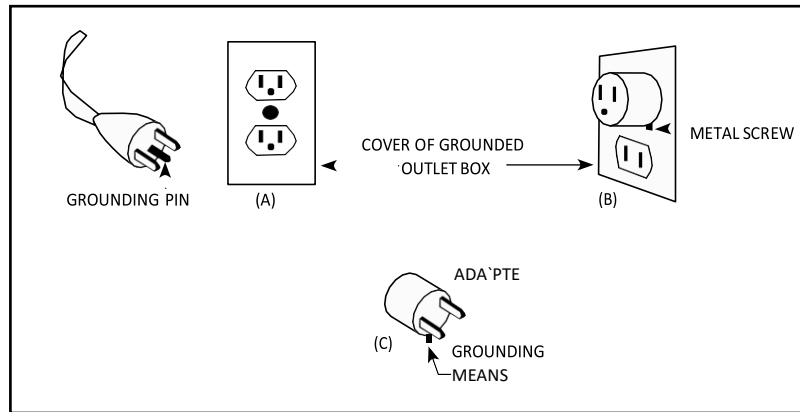



Figure: Outlet/Plug Grounding

Generators:

If a generator must be used, it must be the minimum size listed below or greater. The generator must have a 30A circuit and capable of providing a minimum of wattage at the required voltage. Under size generators will cause motor damage and is not covered under warranty. In addition, only use good quality name brand generators as low-quality generators will create internal electrical noise and clip the sine wave form which will cause the CE414-350 IC boards to malfunction, damages resulting from using under powered or low-quality generators are not covered under any warranty.

OPERATIONAL CHECK LIST



 Always observe all safety instructions and all information in this document before using this machine!

Check list for use (keywords only!) 

- Before start-up:
 - Power tool in an operationally safe condition! Operating instructions complete
 - Read and Understand Silica Dust and Prop 65 Warnings page 5
 - Prescribed PPE and Work Clothing page 8-9
 - Working area inspected and secured page 6
 - Norton Diamond Blade for Material and CE414-350S page 25
 - Blade installed Correctly page 18-19
 - Blade Guard in best position page 20
 - Read and Understand Kickback Warnings page 12-13
page 25
- During work– generally safe work: Operating instructions complete
 - Inspecting the working environment 7
 - Water connection for wet cutting page 20
 - Proper cutting technique page 25-29
- After work: Operating instructions complete
 - Cleaning and care page 30-31
 - Replacing the carbon brushes page 31-33
 - Using the flip stand page 33
 - Maintenance Operating instructions complete

BLADES



Only use Diamond Blades that correspond to the standards ANSI B7.1, EN 12413 and EN 13236 and that are perfectly undamaged. The approved maximum speed of the cutting disc must be $\geq 4,450$ rpm (min^{-1}).

For cutting of metals (hot cutting) and cutting of mineral based materials – block, brick, concrete, stone (cold cutting), different diamond blades are offered. Use only the blades that are approved for the material to be cut. Only use Diamond blades with soft bonds and low diamond concentration that are suitable for the material being cut. Using hard bonded blades (general purpose and low-priced blades) or diamond blades with high diamond concentrations or large diamonds will create additional drag on any electric motor which can over time lead to over heating/motor damage and is not covered under any warranty.

Diamond cutting blades are only approved for cutting mineral-based materials. When installing the diamond blade, always observe the rotating direction indicated on the diamond blade; otherwise, the cutting effect will reduce quickly from diamond loss.

Rotating direction of the blade in the installation process see: BLADE INSTALLATION/REMOVAL pages 18-19 for details.

Synthetic resin based thin wheel cut of blades must not be exposed to moisture. The water connection for wet cutting must not be used when using synthetic resin cut off blades. Synthetic resin blades must not be used in high humidity or in rain. Only use synthetic resin blades until the end of the best-before date imprinted on the blade blotter or shipping box.

The power tool's spindle is designed for cutting discs with an inner bore of 20 mm.

Blades with an 1" inner bore must only be installed with the spindle adapter provided with the CE414-350. Using other spindle adapters may not allow the blade to be properly secured to the machine.

Installation of blades with 1" inner bore see: □ Chap. 5.1, page 14

Blades with other inner bores must not be installed!

New blades must be tested for at least 60 seconds at the indicated maximum speed before the first cutting process. Take care that no body parts are in the path of the blade.



Use Only Genuine Norton Clipper Diamond Blades
For assistance with choosing the correct Norton Clipper
Diamond Blade for your application call customer service
at 1-800-554-8003

PREMISSIBLE CUTTING AREA AND DANGER FROM KICKBACK/DRAWING ALONG

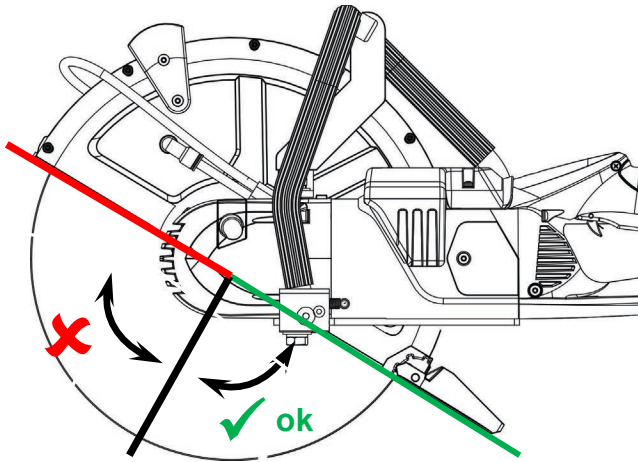

X The upper part of the blade must not be used for cutting!

✓ Only the lower part of the blade can be used for cutting!



Danger of injury from kickback!

Kickback results when the upper part of the blade is used for cutting.

The power tool can be pushed towards the user's causing loss of operator control which can result in injury.

- Never cut with the upper area of the blade!
- Take special care when inserting the blade into cutting areas already started!



Danger of injury from drawing along!

Drawing along results when the cutting path becomes very narrow or from pinching the blade and the power tool is pulled away from the operator.

The power tool can accelerate away from the operator at high speeds and can result in injury.

- Always perform cutting at full rpm and repeated insertion into the cut at points already started.
- Always support the work piece so that the cutting point does not move and so that the cutting blade is not clamped or pinched.
- When starting a cut, always carefully move the cutting blade to the work piece; do not force the blade into the work.
- Only cut one item at a time!
- Ensure that no other work piece is touched when cutting.

CUTTING TECHNIQUE

- For complex cutting processes, cutting direction, and order of the cuts to be performed must be specified in advance to prevent clamping of the cutting blade by the moving debris or injury from dropping parts.
- Always hold the power tool with both hands. Have the one hand on the rear handle, and the other hand on the top handle. Firmly grasp the handles with your hands.
- Operate the power tool at full speed whenever cutting.
- Direction change, side pressure or tilting of the power tool during cutting is forbidden and can cause kick back or drawing along – both of which can result in injury.
- When shortening work pieces use a secure support and secure the work piece against slipping and twisting. The work piece must not be held with your foot or by another person.
- Always be ready for sudden kickback of the work piece and the possibility of quickly moving away from the work area.
- Observe that debris coming out of the cut can cause injury and property damage.

CUTTING METAL



Always wear breathing protection when dry cutting.

Due to friction created by the rotating cutting blade metals are heated to extremely high temperatures. Be aware of hot flying sparks, and that the blade and material will be hot enough to cause personal injury or catch objects on fire.

- Swivel the blade guard down as far as possible for sparks to fly forward where possible, i.e. away from the user.
- Before cutting, specify and mark the cutting line, and approach the material with the blade at full speed.
- Only cut straight and vertically. Do not tilt.
- For a secure and smooth cut, it is best to push or move the power tool forward (away from the operator) in a controlled fashion (step cutting). When moving the power tool forwards, do not force the blade into the material.
- Large diameter round rods are best cut in steps.
- Thin tubes can be cut with a single sinking cut (plunge).
- Tubes with large diameters should be treated like large diameter rods. To avoid tilting and for better control of the cutting process, do not let the blade plunge into the material too far. Always cut flat around.
- I-beam or angled steel should be cut in steps.
- Steel bands or steel plates are cut like tubes, pulling flat with long cutting area.
- Material under tension (supported or material in a wall) always must be grooved slightly on the pressure side and then cut from the pulling side so that the cutting disc is not clamped.

CUTTING CONCRETE/MASONRY MATERIALS

Lots of fine dust occurs when cutting mineral materials such as block, brick, concrete, asphalt, and stone. We recommend that you use the water connection of the power tool when cutting mineral materials, and to use cutting discs suitable for wet cutting.

When cutting with water supply, the dust is bound, visual inspection is improved, and the diamond blade service life is increased by the cooling effect of the water.

Water connection for wet cutting: □ **Water Connections for Wet Cutting**, page 20

Mineral materials are torn out at the point of contact and ejected from the cutting groove by the fast rotation of the cutting blade.

- Swivel the Blade Guard down as far as possible to protect the operator from cut particles.
- Mark the cutting line and cut a groove of approx. 3/16" (5mm) deep along the entire line with the motor running at full speed. This groove will be used as a guide during subsequent cuts.
- Perform the cutting process with even movements forward and back.
- When cutting thin pieces of stone, it may not be possible to cut completely through the stone without pinching the blade. In this case cut as deep as possible and then break the stone in half on a flat support.
- For best performance step cut.
- Do not force the blade into the cut.

STEP CUTTING

Step cutting is the process of removing material in shallow steps per pass rather than a deep single full depth cutting action. Diamond blades are actually grinding wheels and grinding wheels work more efficiently with shallower passes. It is recommended to cut at 1" to 1-1/2" per pass.

Step cutting will reduce the load on any machine, increase blade life, and decrease the cutting time especially when cutting harder materials. In addition, full depth cutting will increase any electrical motor's amperage draw which will lead to overheating, motor damage, and tripping of circuit breakers.

Steps for Step Cutting with the CE414-350SS

1. Verify that the Diamond Blade being used is correct for the material being cut with the CE414-350SS
2. Follow all steps in the OPERATIONAL CHECK LIST located on page 23
3. Mark a straight cut path with a chalk line
4. When cutting run the machine at full speed with a water flow rate enough that the slurry is the consistency of a watered-down milk shake
5. Slowly lower the blade into the material about 1/4" (6mm) while keeping the blade perpendicular to the work surface

6. Slowly cut score a line along the cut path. NOTE: The forward speed can be increased but pay close attention to the sound of the motor, blade, and warning lights. If the motor starts to stall slow down your forward cutting speed. Stalling is a sign of cutting too deep, cutting too fast, applying too much downward pressure on the blade, not holding the blade straight to the cut line or perpendicular to the material, or the incorrect Diamond Blade is being used.
 - a. Keep the blade perpendicular to the material and the cut path as straight as possible
7. Remove the blade from the cut when your cutting distance is reached
8. Release the trigger and wait for the blade to stop rotating
9. Turn off the water flow
10. Move back to the starting point of the cut line
 - a. Reposition power cable out of the way of your cut line and any water puddles
 - b. Do not transport the CE414-350SS while the blade is rotating.
11. Restart the water flow to the same rate as the previous cut. Adjust the flow rate as necessary.
12. Depress the CE414-350SS power trigger and allow the machine to get up to full speed
13. While keeping the blade perpendicular to the work surface slowly lower the Diamond Blade to the depth of 1" to 1-1/4" (25 to 32mm)
14. Slowly move the blade forward along the cut line.
15. Repeat steps 7 to 14 until the cut is completed.

NOTES: Take breaks when you begin to feel fatigued.
 Do not overextend yourself or lose balance
 Pay attention to your surroundings, the machine, and blade
 Always wear proper PPE

MAINTENANCE



Maintenance, service, and repairs of all state-of-the-art power tools must be done by a qualified service technician. Some maintenance, service and repairs may require specialized tools and training. We recommend all work to be performed by the Norton Clipper selling Distributor or Norton Clipper Authorized Service Center. We also recommend that all work not described in these operating instructions and all work you are not comfortable with be performed by the Norton Clipper selling Distributor or Norton Clipper Authorized Service Center. The Norton Clipper selling Distributor or Norton Clipper Authorized Service Center technicians have the required training, experience, and equipment and can make the most cost-efficient solution available to you. He will advise and support you. For the nearest Norton Clipper selling Distributor or Norton Clipper Authorized Service Center please contact customer service at 1-800-554-8003.



Observe ALL safety instructions before beginning any maintenance, service, or repair work!



After a run-in time of approx. 5 operating hours, all screws and nuts that can be reached must be checked for tight fit and tightened again if required.

It is best to keep the power tool in a dry and safe location when not in use. Do not allow the power tool motor, switch, or electrical connections to become wet.

CLEANING AND CARE



This power tool must be cleaned thoroughly after each workday and inspected for damage; in particular the cooling air openings around the brushes, power switch, and blade guard, material deposits will form over time (in particular when wet cutting), which may impair free rotation of the cutting disc.

Only use the environmentally friendly cleaning products that are safe for Nylon, Plastics, Aluminium, and Magnesium. Never use fuel to clean!

NEVER pressure wash any electrical power tool.

- Remove material deposits from inside the blade guard with a piece of wood or similar object that will not damage the blade guard.
- Clean and inspect the blade shaft (spindle) and blade collars (flanges).
- The blade collars should be one piece, flat with recess, free of all debris and all foreign material, free of damage, and are the correct size.
- Clean the blade and check it for damage. If any damage is found, replace the blade immediately and dispose of the blade so that it cannot be reused.

MAINTENANCE SCHEDULE

Regular Service Period Performed At Every Indicated Period →		After First Hour of Work	Beginning Of Day	During Blade Change	End Of Day	Once A Week	After Failure	After Damage
		Whole Machine	Inspect For Damaged or Missing Components	X	X	X	X	X
	Clean		X			X		
Blade Collars	Clean			X				
Water Hose, Water Fittings, and Nozzles	Clean		X			X		
	Inspect		X			X		X
Reachable Hardware	Tighten					X		

REPLACING CARBON BRUSHES



This electrical power tool is powered by a high horsepower low amperage air over brush motor. Replace the brushes when the motor begins to lose power. Brushes will typically need to be replaced during the life of the saw. Replace the brushes when over 2/3 of their original length is used (when the overall length of the brushes is less than 7/16" (11.1mm)). It is normal for the brushes to wear down.

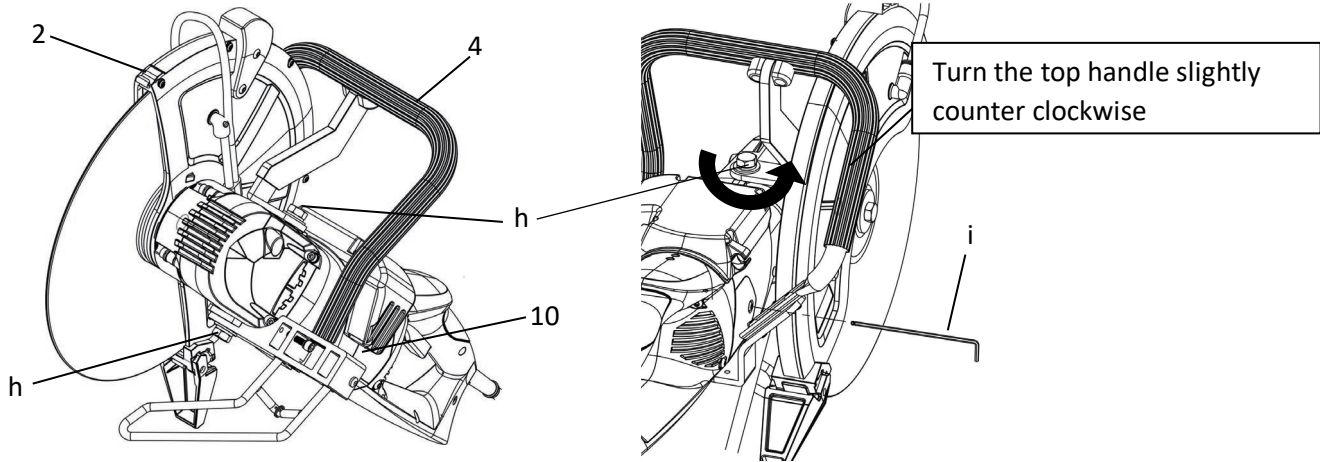

Brush replacement:

- Disconnect the electrical supply.
- Loosen the two bolts (h) slightly on the top handle.
- Turn the top handle slightly counter clockwise as shown above to give the brush cover on the protective cowl (2) side of the power tool room for removal.
- Using a 3mm hex key wrench (i) to open the carbon brush cover on both sides of the tool.

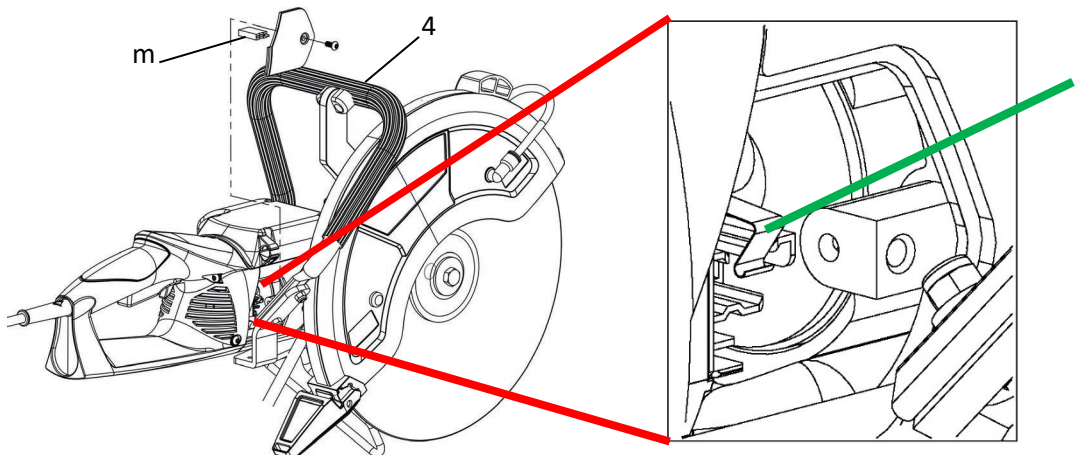

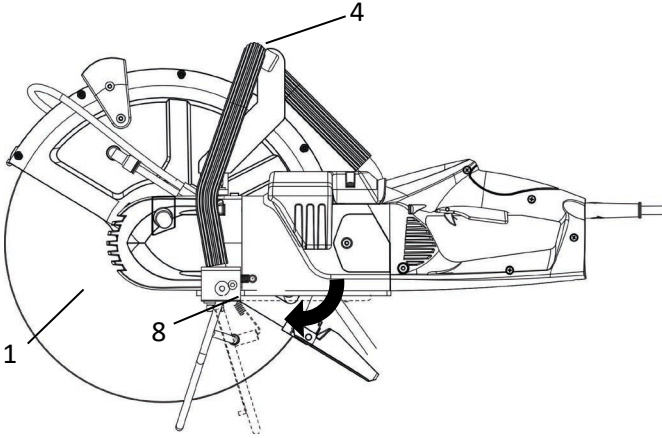

- Pull the compression spring back (j) and to the side so that it rests on either side of the carbon brush holder (k).
- Remove the carbon brushes (m). Use compressed air to remove any carbon build-up on the armature and to check for any signs of excessive wear. The armature can be rotated by hand by carefully turning the commutator (element the carbon brushes were pressed against) with your finger. Be careful not to leave any greasy residue on this surface.
- Place the new carbon brushes into the carbon brush holder (k).
- Reinstall the carbon brush covers.
- Return the top handle (4) into its correct position. Retighten the mounting bolts (h).

USING THE KICK STAND



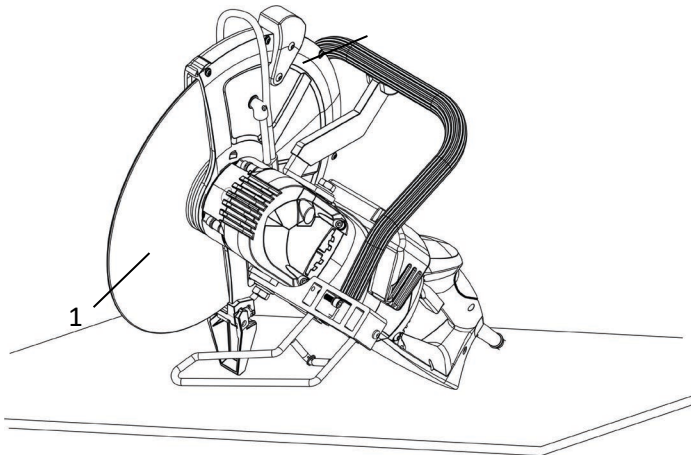

This power tool is packaged with a Kick Stand (8) retracted. With the one hand hold the tool by the top handle (4), if the saw has been used the cutting blade (1) should no longer be in motion, use your other hand to deploy the Kick Stand (8). Hold the machine as close to the Center brace as possible, designated with a vertical arrow on the left. This position provides the best balance for this tool during transportation.

  When manipulating the Kick Stand (8) the cutting blade (1) must not be moving



Place the power tool down on the ground as shown on left. Even when leaned over, this machine is very stable. Do not attempt to set the machine down until the cutting blade (1) has stopped moving. Using the Kick Stand will prevent unintentional damage to your equipment by reducing its footprint in your workspace. Furthermore, the cutting blade and the motor body are easier to maintain while in this position.

  Before setting the power tool down on the Kick Stand, wait until the cutting blade (1) is no longer moving.

TROUBLE SHOOTING

CE414-350SS will not start:

1. Verify Power is connected
2. Verify that power supply
 - a. 20 AMP Minimum is recommended for best performance
 - b. Verify that the Power Supply is Active
 - i. If OFF check circuit breaker at the Power Supply.
 - ii. If ON a Generator verify that the Generator is ON, reset circuit breaker on the Generator
3. Verify that GFCI (PCD) is not in the off position. Press Reset Button on GFCI (PCD)
4. Verify that the ON light is lit on the GCFI
 - a. If the PN light is not Lit
 - i. No Power
 - ii. Disconnected Extension Cord
 - iii. Damaged GFCI
5. Check Brushes for Wear or Damage. Replace if necessary. NOTE: Water will damage the Brushes and is not covered under warranty. Brushes are a normal wear part.

PARTS BREAKDOWN

1. Provide the model number and serial number of the machine from the machine name plate.
2. Provide the UPC number, part number, and description of part.
3. Whenever alternate parts are shown due to product improvement, inspect the part you have and provide additional description as necessary.
4. Specify mode of shipping desired, for example, parcel post, truck, air freight, UPS., best way, etc.

Contact Customer Service:
Saint-Gobain Abrasives
2770 West Washington
Stephenville, TX 76401

Phone: 800-554-8003
Fax: 254-918-2312

Web: www.nortonconstructionproducts.com

NOTE: All Parts Are Sold as Individual (each) Unless Noted Otherwise

Use Only Clipper Diamond Blades. Contact your local Norton Clipper Distributor or our Customer Service at 800-554-8003 for the best blade for the application.

All parts are designated as either Service Parts (S) or Wear Parts (W) in the Type column in the parts listing. Wear parts are worn out through normal use of the machine. The wear period depends on the intensity of use of the machine, handling, and maintenance of the machine. Wear parts must be serviced and eventually changed following the indications of the manufacturer. Any wear due to normal use of the machine will not be considered as a case of warranty for items designated as Wear Parts (W). For best performance and life Genuine Norton Clipper replacement parts should always be used. Changes to part specifications, are subject to change without notice.

MOTOR ASSEMBLY / ENSAMBLE DEL MOTOR / ASSEMBLAGE MOTEUR

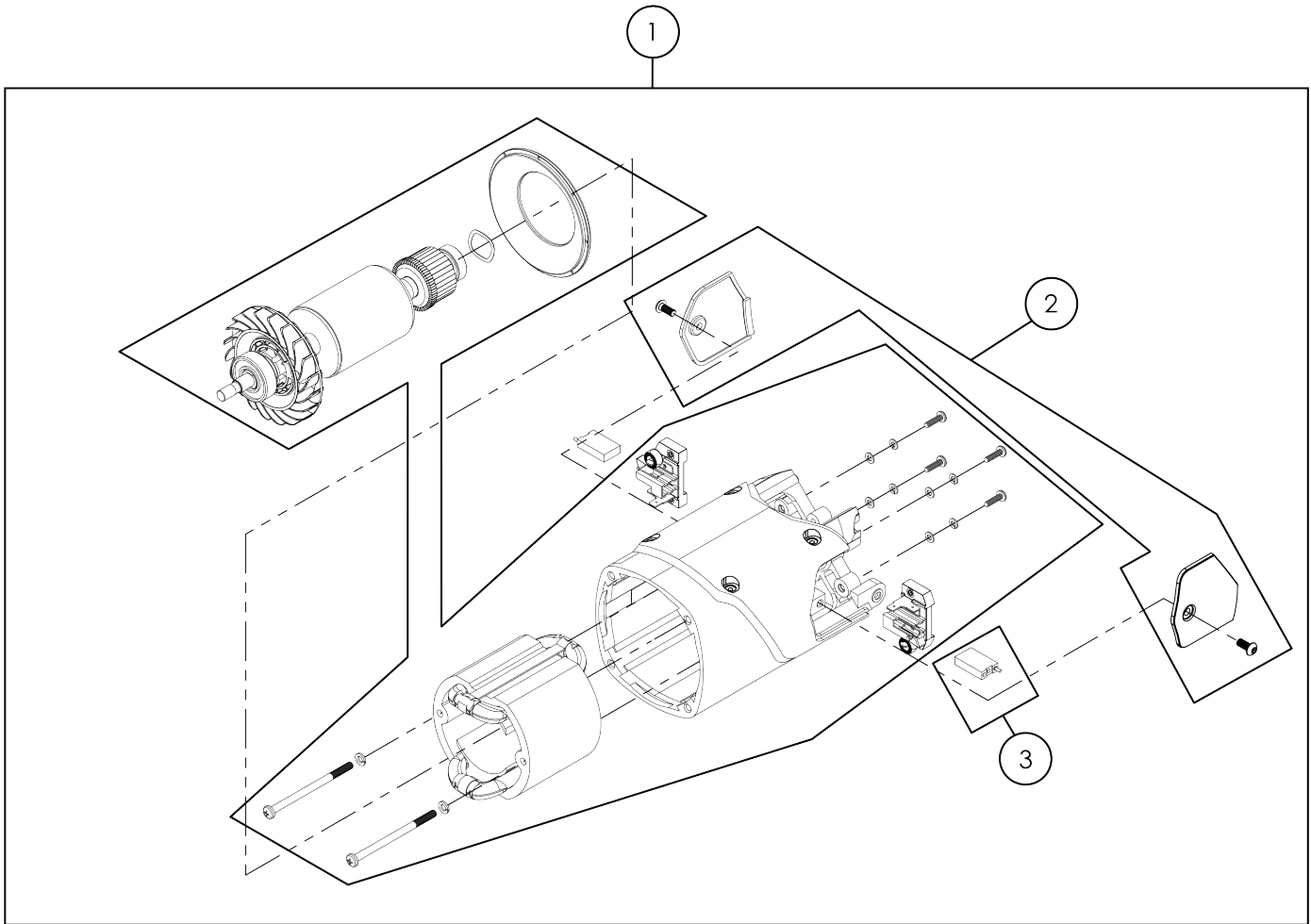

Motor Assembly / Ensemble del Motor / Assemblage Moteur

POS	UPC	Description	Descripción	Description	Type	QTY	NOTES
1	70184633186	MOTOR ASSEMBLY CE414-350SS	CONJUNTO DE MOTORES CE414- 350SS	ENSEMBLE MOTEUR CE414-350SS	S	1	<i>Includes: Armature, Field Windings, Wave Washer, Brushes, Brush Door Covers, w/Hardware</i>
2	70184633174	BRUSH DOOR ASSY (2)	CONJUNTO DE LA PUERTA DEL CEPILLO (2)	ENSEMBLE DE PORTE DE BROSSE (2)	S	1	<i>Brush doors set of 2 w/hardware</i>
3	70184633168	CARBON BRUSHES CE414-350 (2)	ESCOBILLA DE CARBONO (2) CE 414- 350 SS	BALAI DE CHARBON (2) CE 414-350 SS	W	1	<i>Brushes set of 2</i>

Type: S = Service Part, W = Wear Part, All Parts Are Sold as Individual (each) Unless Noted Otherwise

Order by **UPC** number. Kit Items Components are listed in the NOTES.

BLADE GUARD ASSEMBLY / CONJUNTO DE PROTECCIÓN DE LA HOJA / ASSEMBLAGE DU PROTÈGE-LAME

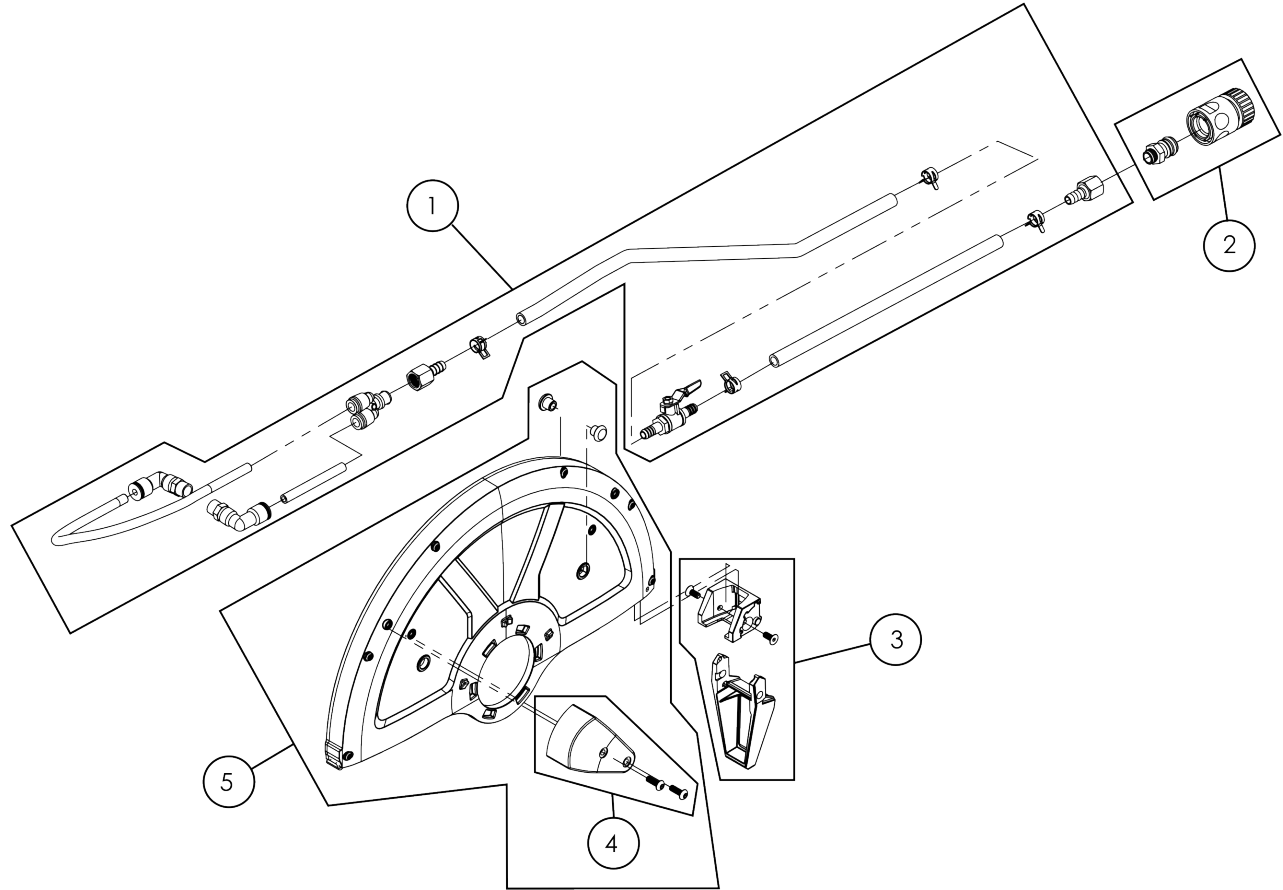

Blade Guard Assembly / Conjunto de Protección de la Hoja / Assemblage du Protège-Lame

POS	UPC	Description	Descripción	Description	Type	QTY	NOTES
1	70184633180	WATER HOSE KIT CE414-350	KIT MANGUERA AGUA CE414-350	TUYAU D'EAU CE414-350	W	1	Includes: All hoses, fittings, clamps, and valve assembled. DOES NOT include Quick Detach Water Fittings C E414-350-005
2	70184633184	QD GARDEN HOSE ADAPTER KIT M+F	KIT DE ADAPTADOR DE MANGUERA DE JARDÍN QD M+H	KIT D'ADAPTATEUR POUR TUYAU D'ARROSAGE QD M+F	W	1	Includes: Male and Female Quick Detach Garden Hose Fittings
3	70184633164	SPLASH GUARD KIT CE414-350SS	KIT DE PROTECCIÓN CONTRA SALPICADURAS CE414- 350SS	ENSEMBLE PARE- ÉCLABOUSSURES CE414- 350SS	S	1	Include: Splash Guard w/Hardware
4	70184633179	HANDLE KIT BLADE GUARD C414-350SS	KIT MANGO PROTECTOR CUCHILLA C414-350SS	KIT POIGNÉE PROTÈGE- LAME C414-350SS	S	1	Includes: Handle w/Hardware
5	70184633185	BLADE GUARD KIT CE414-350SS	KIT DE PROTECCIÓN DE HOJA CE414-350SS	ENSEMBLE DE PROTÈGE- LAME CE414-350SS	S	1	Includes: Blade Guard, Blade Guard Handle Kit, and Slash Guard Kit

Type: S = Service Part, W = Wear Part, All Parts Are Sold as Individual (each) Unless Noted Otherwise

Order by **UPC** number. Kit Items Components are listed in the NOTES.

FORWARD HANDLE ASSEMBLY / CONJUNTO DE MANIJA DELANTERA / ASSEMBLAGE DE LA POIGNÉE AVANT

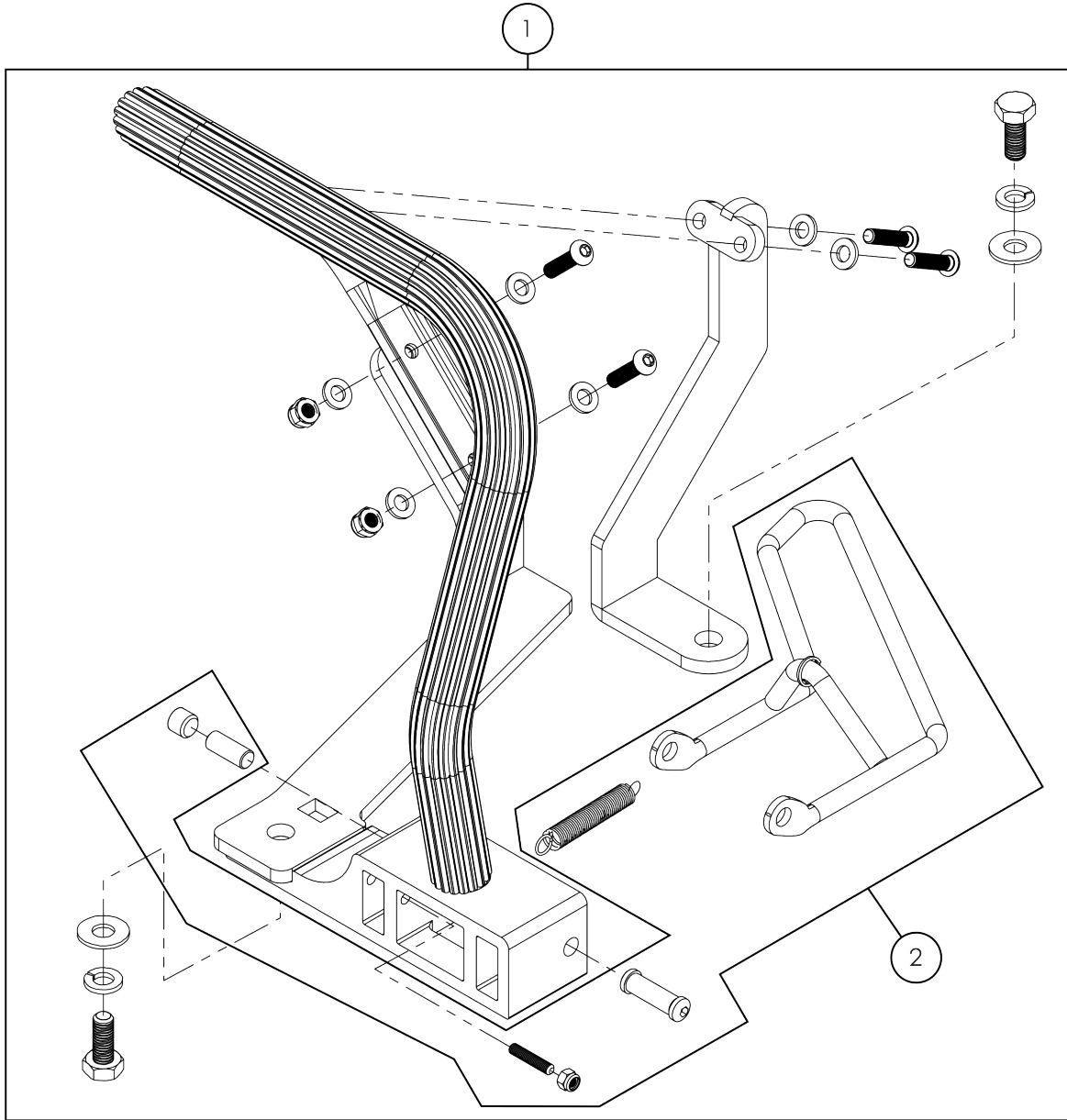

Forward Handle Assembly / Conjunto de Manija Delantera / Assemblage de la Poignée Avant

POS	UPC	Description	Descripción	Description	Type	QTY	NOTES
1	70184633169	FORWARD HANDLE ASSEMBLY CE414-350SS	CONJUNTO DEL MANGO DELANTERO CE414-350SS	ENSEMBLE DE POIGNÉE AVANT CE414-350SS	W	1	Includes: Handle, Handle Support, Kick Stand w/spring, and w/Hardware
2	70184633170	KICK STAND ASSEMBLY CE414-350SS	CONJUNTO DE SOPORTE CE414-350SS	ENSEMBLE BÉQUILLE CE414-350SS	W	1	Includes: Kick Stand w/spring, and hardware

Type: S = Service Part, W = Wear Part, All Parts Are Sold as Individual (each) Unless Noted Otherwise
Order by **UPC** number. Kit Items Components are listed in the NOTES.

GEAR BOX ASSEMBLY / CONJUNTO DE CAJA DE CAMBIOS / ASSEMBLAGE DE LA BOITE DE VITESSES

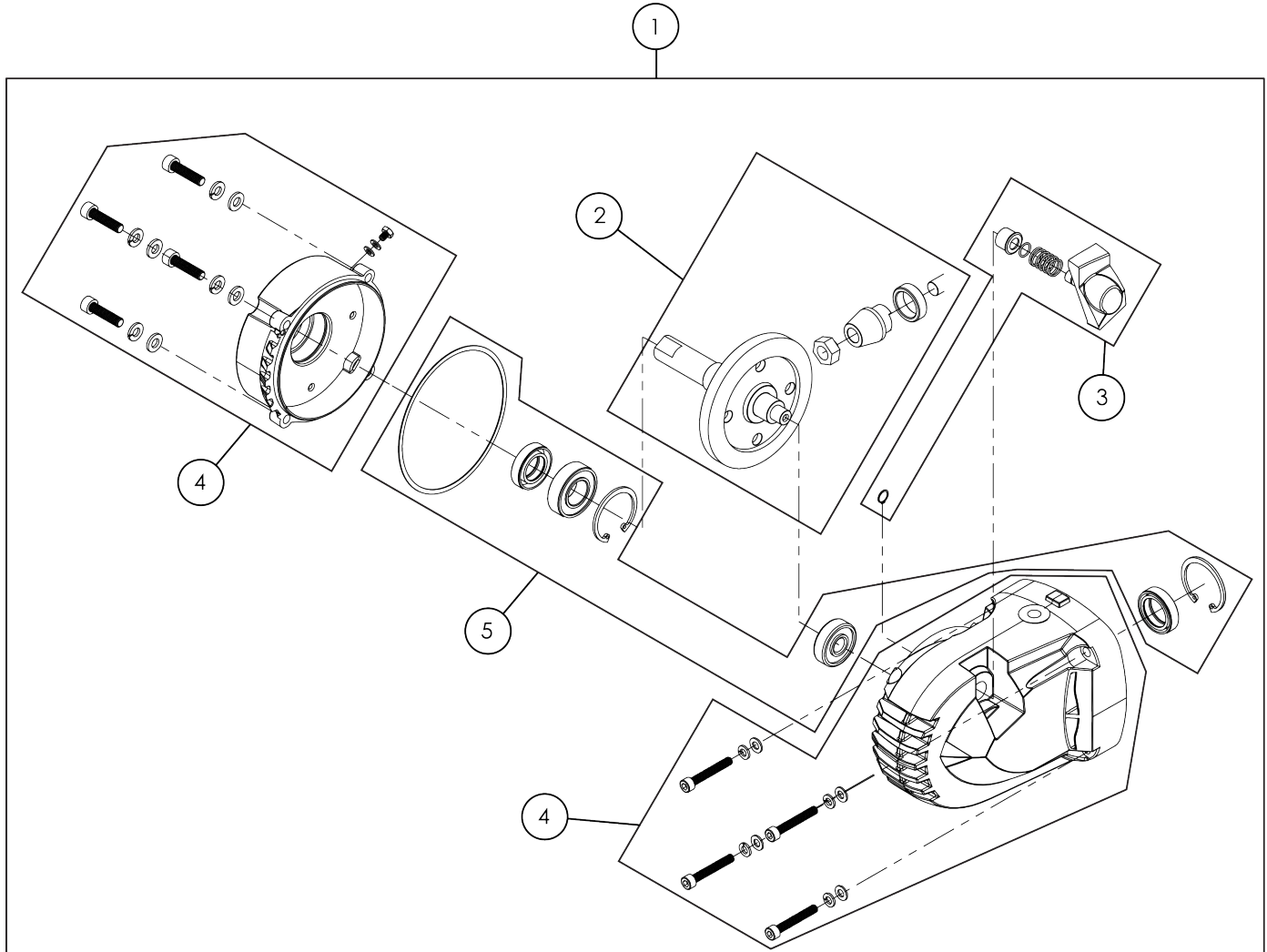

Gear Box Assembly / Conjunto de Caja de Cambios / Assemblage de la Boîte de Vitesses

POS	UPC	Description	Descripción	Description	Type	QTY	NOTES
1	70184633167	GEAR BOX COMPLETE ASSEMBLY CE414-350SS	CAJA DE ENGRANAJES CONJUNTO COMPLETO CE414-350SS	BOITE DE VITESSES ENSEMBLE COMPLET CE414-350SS	S	1	Includes (All items shown in the image): Blade Shaft Lock Assembly, Blade Shaft and Pinion Gear Assembly, Gear Box Housing w/Hardware, and Bearing and Shaft Kit Gear Box
2	70184633175	BLADE SHAFT and PINION GEAR ASSEMBLY CE414-350SS	EJE DE LA HOJA y CONJUNTO DEL ENGRANAJE DEL PIÑÓN CE414-350SS	ENSEMBLE ARBRE DE LAME ET PIGNON CE414-350SS	S	1	Includes: Blade Shaft w/Gear, Nut Pinion, Pinion Gear, and Shaft Seal

Type: S = Service Part, W = Wear Part, All Parts Are Sold as Individual (each) Unless Noted Otherwise
Order by **UPC** number. Kit Items Components are listed in the NOTES.

GEAR BOX ASSEMBLY / CONJUNTO DE CAJA DE CAMBIOS / ASSEMBLAGE DE LA BOITE DE VITESSES

POS	UPC	Description	Descripción	Description	Type	QTY	NOTES
3	70184633176	BLADE SHAFT LOCK KIT CE414-350SS	KIT DE BLOQUEO DEL EJE DE LA HOJA CE414- 350SS	KIT DE BLOCAGE D'ARBRE DE LAME CE414-350SS	S		<i>Includes: Blade Shaft Lock, Spring, Blade Shaft Lock Button, and two (2) O-Rings</i>
4	70184633177	GEAR BOX HOUSING KIT w/HARDWARE CE414-350SS	KIT DE ALOJAMIENTO DE CAJA DE ENGRANAJES CON HARDWARE CE414- 350SS	KIT DE LOGEMENT DE BOÎTE DE VITESSES avec QUINCAILLERIE CE414- 350SS	S	1	<i>Includes: Gear Box Castings (Inner and Outer), and hardware</i>
5	70184633178	BEARING and SEAL KIT GEAR BOX CE414- 350SS	KIT COJINETE Y SELLO CAJA DE ENGRANAJES CE414-350SS	KIT ROULEMENTS ET JOINTS BOITE DE VITESSES CE414-350SS	S	1	<i>Includes: Seal Gear Box Outer, Bearing Outer, Bearing Inner, Seal Inner, Snap Rings (Qty=2), O'Ring, w/Hardware</i>

Type: S = Service Part, W = Wear Part, All Parts Are Sold as Individual (each) Unless Noted Otherwise

Order by **UPC** number. Kit Items Components are listed in the NOTES.

REAR HANDLE ASSEMBLY / MONTAJE DE LA MANIJA TRASERA / ASSEMBLAGE DE LA POIGNEE ARRIERE

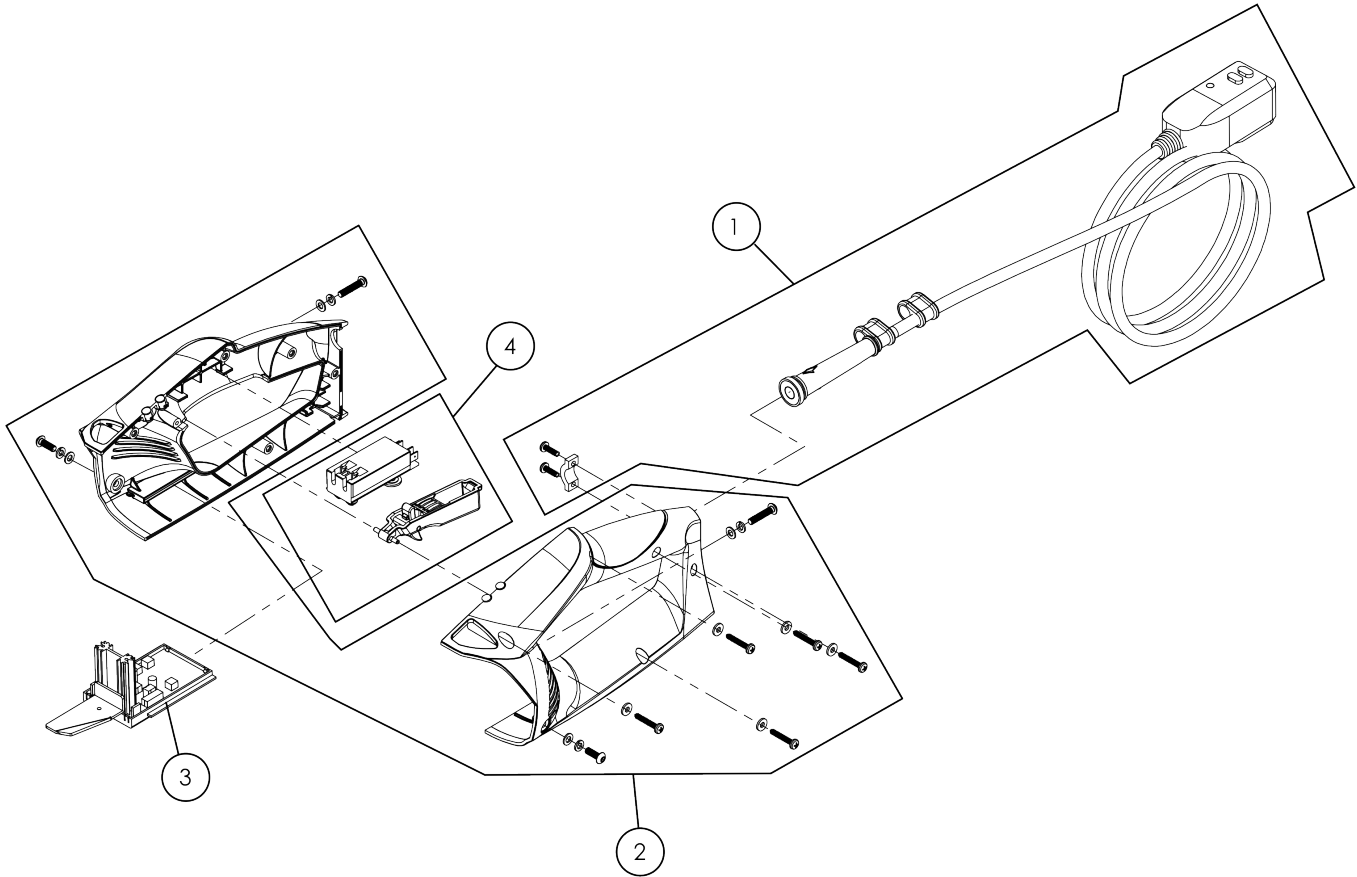

Rear Handle Assembly / Montaje de la Manija Trasera / Assemblage de la Poignée Arrière

POS	UPC	Description	Descripción	Description	Type	QTY	NOTES
1	70184633173	POWER CABLE ASSY w/GFCI CE414-350SS	CONJUNTO DE CABLE DE ALIMENTACIÓN con GFCI CE414-350SS	CÂBLE D'ALIMENTATION AVEC DDFT CE414-350SS	S	1	Includes: Cable Clamp w/Hardware, StrainRelief (2), Cable Gland, and Power Cable w/GFCI
2	70184633171	REAR HANDLE ASSY CE414-350SS	CONJUNTO DE MANGO TRASERO CE414-350SS	POIGNEE ARRIERE CE414-350SS	S	1	Includes: Handle Left and Right Side, w/Hardware
3	70184633163	IC BOARD CE414-350SS	TARJETA CI CE414-350SS	CARTE CI CE414-350SS		1	
4	70184633172	SWITCH ASSEMBLY CE414-350SS	CONJUNTO DE INTERRUPTOR CE414-350SS	ENSEMBLE DE COMMUNTEUR CE414-350SS		1	Includes: Switch Body and Switch Trigger

Type: S = Service Part, W = Wear Part, All Parts Are Sold as Individual (each) Unless Noted Otherwise
Order by **UPC** number. Kit Items Components are listed in the NOTES.

MAIN ASSEMBLY / ASAMBLEA PRINCIPAL / ASSEMBLAGE PRINCIPAL

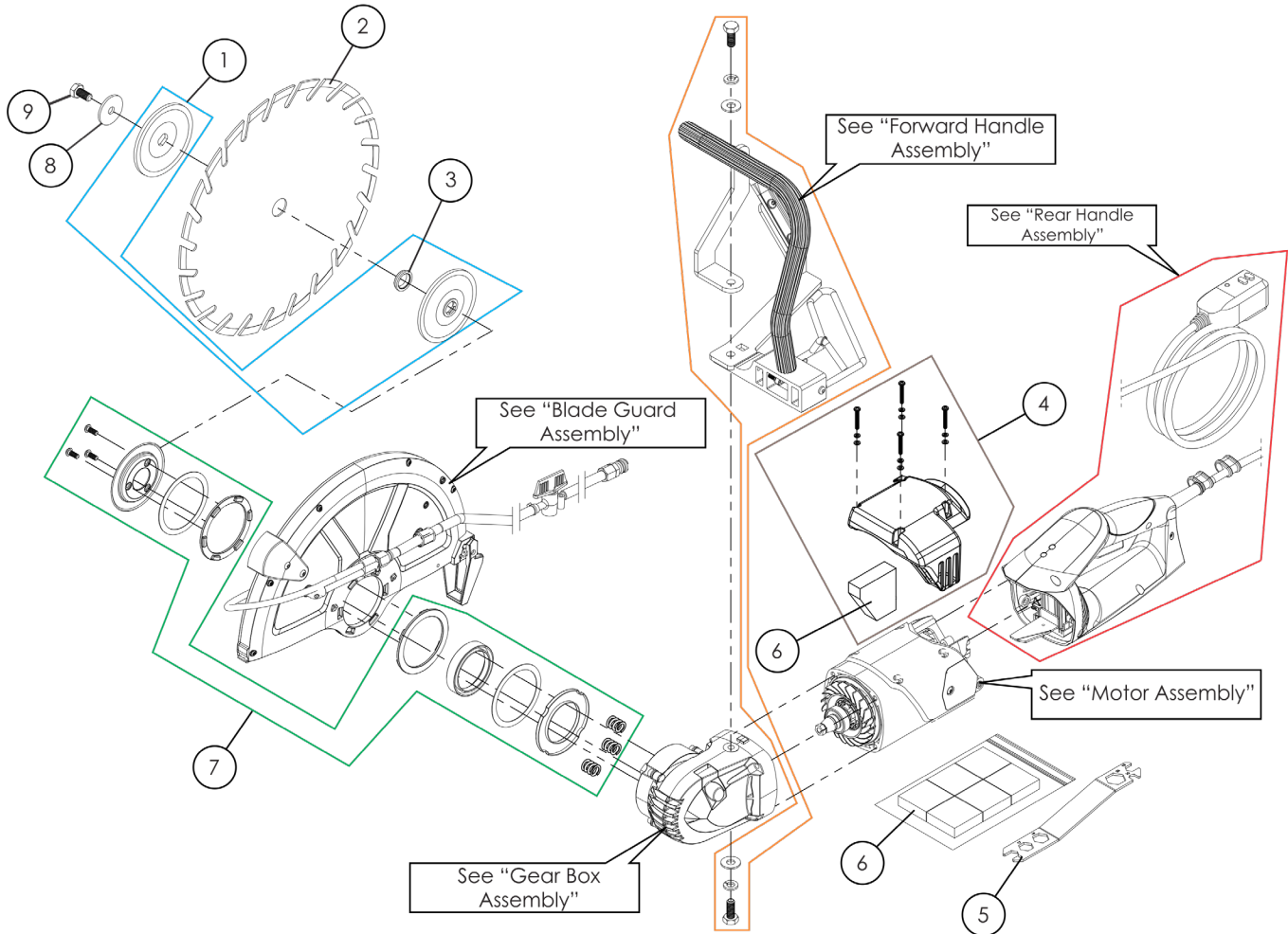

Main Assembly / Asamblea Principal / Assemblage Principal

POS	UPC	Description	Descripción	Description	Type	QTY	NOTES
1	70184633181	COLLAR SET (LOOSE+INNER+ADP) CE414-350SS	CONJUNTO COLLAR (SUELTO+INTERIOR+ADP) CE414-350SS	JEU DE COLLIERS (LÂCHE+INTÉRIEUR+ADP) CE414-350SS	S	1	Includes Loose, Tight Flange, and Blade Adapter
2	70184684525	CGHSTS1420 14" x .125 x 1"/20mm Charger Turbo	CGHSTS1420 14" x .125 x 1"/20mm Cargador Turbo	CGHSTS1420 14" x .125 x 1"/20mm Chargeur Turbo	W		USE ONLY NORTON DIAMOND BLADES. Use of other blades may void the machine's warranty
3	70184633165	ADAPTER 1"/20mm CE414-350	ADAPTADOR 1"/20mm CE414-350	ADAPTATEUR 1"/20mm CE414-350	S	1	
-NA-	-NA-	Forward Handle Assembly Page 34	Ensamblaje del mango delantero Página 34	Assemblage de la poignée avant Page 34	S		See Page 34 for Details
-NA-	-NA-	Rear Handle Assembly Page 36	Montaje de la manija trasera Página 36	Assemblage de la poignée arrière Page 36	S		See Page 36 for Details. IC Board Sold Separately
4	70184633183	AIR INTAKE w/HARDWARE and FILTER PACK CE414-350SS	ENTRADA DE AIRE con HARDWARE y PAQUETE DE FILTRO CE414-350SS	PRISE D'AIR avec QUINCAILLERIE et FILTRE PACK CE414-350SS	S	1	Includes: Air Intake, attachment hardware, and Air Filter 6 pack

Type: S = Service Part, W = Wear Part, All Parts Are Sold as Individual (each) Unless Noted Otherwise

Order by **UPC** number. Kit Items Components are listed in the NOTES.

MAIN ASSEMBLY / ASAMBLEA PRINCIPAL / ASSEMBLAGE PRINCIPAL

POS	UPC	Description	Descripción	Description	Type	QTY	NOTES
-NA-	-NA-	Motor Assembly Page 30	Montaje del Motor Página 30	Assemblage du Moteur Page 30	S		See Page 30 for Details
5	70184680905	WRENCH UNIVERSAL	LLAVE UNIVERSAL	CLE UNIVERSELLE	S	1	
6	70184633166	AIR FILTER 6 PACK CE414-350SS	PAQUETE DE 6 FILTROS DE AIRE CE414-350SS	FILTRE A AIR PACK DE 6 CE414-350SS	W	1	Air Filter 6 pack. NOT SOLD as EACH
-NA-	-NA-	Gear Box Assembly page 35	Conjunto de Caja de Cambios Página 35	Ensemble de Boîte de Vitesses Page 35			See Page 31 for Details
7	70184633182	BLADE GUARD RETAINER KIT CE414- 350SS	KIT DE RETENCIÓN DE PROTECTOR DE HOJA CE414-350SS	KIT DE RETENUE DE PROTÈGE-LAME CE414- 350SS	S	1	Includes Retaining rings, springs (3), bushings, and attachment hardware as shown.
8	70184600788	WASHER M10 X 40 X 3 BLADE SHAFTS	ARANDELA EJE M10 X 40 X 3 HOJAS	RONDELLE M10 X 40 X 3 AXE LAME	S	1	Large Metric Blade Shaft Washer
9	70184600893	SCR M10 X 20 1.5 DIN933 LH	TORNILLO M10 X 20 1.5 DIN933 LH	VIS M10 X 20 1.5 DIN933 GAUCHE	S	1	Left Hand Thread

Type: S = Service Part, W = Wear Part, All Parts Are Sold as Individual (each) Unless Noted Otherwise

Order by **UPC** number. Kit Items Components are listed in the NOTES.

This page is intentionally left blank.

WARNING

Some dust created by power sanding, sawing, grinding, drilling, and other construction activities contains chemicals known to cause cancer, birth defects or other reproductive harm. Some examples of these chemicals are:

- Lead from lead-based paints,
- Crystalline silica from bricks and cement and other masonry products, and
- Arsenic and chromium from chemically-treated lumber.

Your risk from these exposures varies, depending on how often you do this type of work. To reduce your exposure to these chemicals: work in a well ventilated area, and work with approved safety equipment, such as those dust masks that are specially designed to filter out microscopic particles.



**REDEFINING
JOBSITE MUSCLE™**

www.facebook.com/NortonAbrasivesNA | www.youtube.com/NortonAbrasives | www.nortonabrasives.com

USA CUSTOMER SERVICE:

Toll Free Phone: 1 (800) 554-8003
Toll Free Fax: 1 (800) 443-1092

CANADA CUSTOMER SERVICE:

Toll Free Phone: 1 (800) 263-6565
Toll Free Fax: 1 (800) 561-9490

© Saint-Gobain.

Norton, Norton Clipper, "Redefining Jobsite Muscle" and "Transforming surfaces...and beyond" are trademarks of Saint-Gobain. All other trademarks are the property of their respective owners.

