

# CFP 11

SPARE PART LIST

LISTE DE PIECES DE RECHANGE

ERSATZTEILLISTE



**NORTON**<sup>®</sup>

SAINT-GOBAIN

**clipper**<sup>®</sup>



**ENGLISH**

TYPE:

S = Spare part

W = Wear part

NA = Not Available

The kits of spare parts contain all screws and bolts and the components referring itself to it.

Screws and bolts is component of standard assembly, which you can easily find at all the retailers of standard components of assembly.

All the components of standard assembly are of a quality grade 8.8.

We recommend not to use a quality grade lower than 8.8 for all the standard components of assembly.

The parts of replacements Norton CLIPPER must always be used.

Wear parts life will vary based on usage and maintenance of the machine or part. Wear parts will need to be maintained and replaced as needed. No warranty is applied to wear parts.

The components NA (Not Available) are not available in spare part.

**FRANCAIS**

TYPE :

S = Pièce de rechange

W = Pièce d'usure

NA = Non disponible

Les kits de pièces détachées contiennent toute la visserie et les composants s'y rapportant.

La visserie est un composant d'assemblage standard, que vous pouvez facilement trouver chez tous les détaillants de composants d'assemblage standards.

Tous les composants d'assemblage standard sont d'une classe de qualité 8.8.

Nous recommandons de ne pas utiliser une classe de qualité inférieure à 8.8 pour tous les composants d'assemblage standards.

Pour les pièces non standard, les pièces de remplacement doivent impérativement provenir de Norton CLIPPER.

La durée de vie des pièces d'usure varie en fonction de l'utilisation et de la maintenance de la machine ou de la pièce. Les pièces d'usure devront être entretenues et remplacées au besoin. Aucune garantie n'est appliquée aux pièces d'usure.

Les composants NA (Not Available) ne sont pas disponibles en pièce de rechange.

**DEUTSCH**

TYP :

S = Ersatzteile

W = Verschleißteile

NA = nicht verfügbare

Die definierten Ersatzteil-Set's beinhalten alle Ersatzteile wie Komponenten, Schrauben, Muttern etc.

Norm- bzw. Standardteile wie Schrauben, Muttern etc. können bei offiziellen Schrauben- sowie Komponentenhändler bezogen werden.

Alle Norm- bzw. Standardteile wie Schrauben, Muttern etc. entsprechen der Qualitäts- bzw. Festigkeitsklasse 8.8.

Wir empfehlen, keine Norm- bzw. Standardteile wie Schrauben, Muttern etc. unter der Qualitäts- bzw. Festigkeitsklasse 8.8 einzusetzen.

Es dürfen nur geprüfte Norton CLIPPER-Ersatzteile eingesetzt werden.

Die Lebensdauer der Verschleißteile hängt von der Verwendung und Wartung der Maschine oder des Teils ab. Verschleißteile müssen gewartet und bei Bedarf ersetzt werden. Für Verschleißteile wird keine Garantie übernommen.

Ersatzteile sowie Komponenten mit dem Vermerk NA (NA=nicht verfügbar) sind nicht verfügbar.



### Exciter/Système vibrant/Vibrationsystem

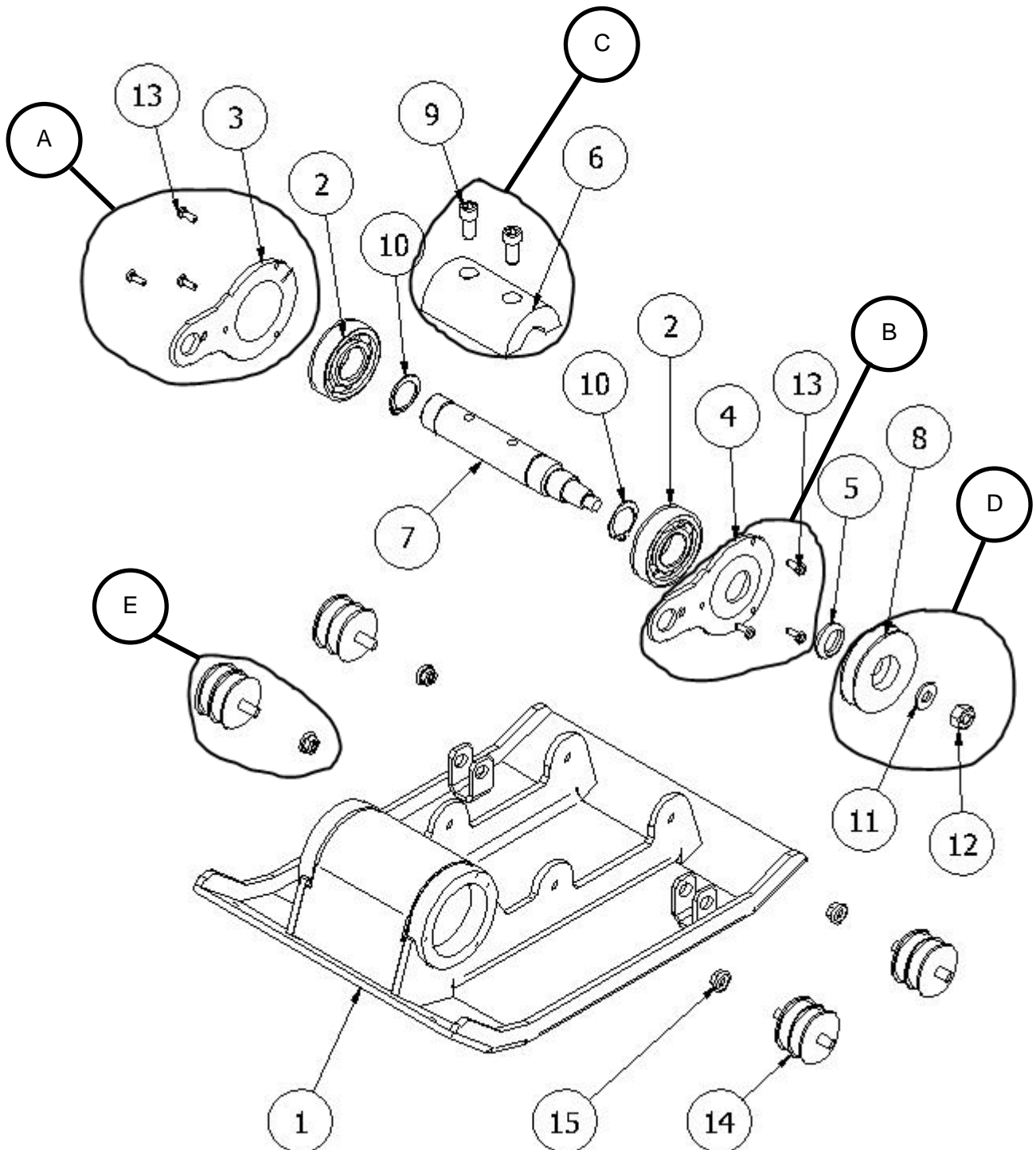

## Exciter - Système vibrant - Vibrationsystem

POS.	DESCRIPTION	Description	Beschreibung	QTY	REF	Type
1	Shoe CFP 11	Plaque CFP 11	Platte CFP 11	1	310576078	S
7	Exciter shaft	Arbre du système vibrant	Vibrierende systemwelle	1	310576079	W
2	Bearing 6307	Roulement 6307	Kugellager 6307	2	310576080	W
A	Blind exciter cover	Couvercle système vibrant	Abdeckung des vibrierenden systems	1	310576081	S
3	Blind exciter cover	Couvercle système vibrant	Abdeckung des vibrierenden systems	1		
13	Screw TE M6X16 UNI5739 ZN	Vis TE M6x16 UNI 5739 Zn	Schrauber TE M6x16 UNI 5739 Zn	3		
B	Open exciter cover	Couvercle système vibrant	Abdeckung des vibrierenden systems	1	310576082	S
4	Open exciter cover	Couvercle système vibrant	Abdeckung des vibrierenden systems	1		
13	Screw TE M6X16 UNI5739 ZN	Vis TE M6x16 UNI 5739 Zn	Schrauber TE M6x16 UNI 5739 Zn	3		
5	Oilseal AE41 30-38-7	Joint AE41 30-38-7	Dichtung AE41 30-38-7	1	310576083	W
C	Mass	Masse	Masse	1	310576084	S
6	Mass 11 KN	Masse 11kN	Masse 11kN	1		
9	Screw TCEI M12X25 UNI 5931 12.10	Vis TCEI M12x25 UNI5931 12.10	Schrauber TCEI M12x25 UNI5931 12.10	2		
10	Seeger E 35	Anneau élastique E35	Elastischer ring E36	2	310576085	S
D	Pulley	Poulie	Riemenscheibe	1	310576107	S
8	Vibrator pulley FP D.83	Poulie du système vibrant FP D83	Riemenscheibe des vibrationsystems FP D83	1		
11	Washer M14 ZN	Rondelle M14 Zn	Scheibe M14 Zn	1		
12	Bolt M14 UNI5588	Ecrou M14 UNI 5588	Mutter M14 UNI 5589	1		
E	Shockmount	Silentblock	Silentblock	1	310576108	W
14	Shockmount D57X37 M10X25 60 SH	Silentblock D57X37 M10X25 60 SH	Silentblock D57X37 M10X25 60 SH	4		
15	Flanged nut DIN 6923-M10	Ecrou DIN 6923- M10	Mutter DIN 6923-M10	4		

# Engine support / Support moteur/ Motor unterstutzung

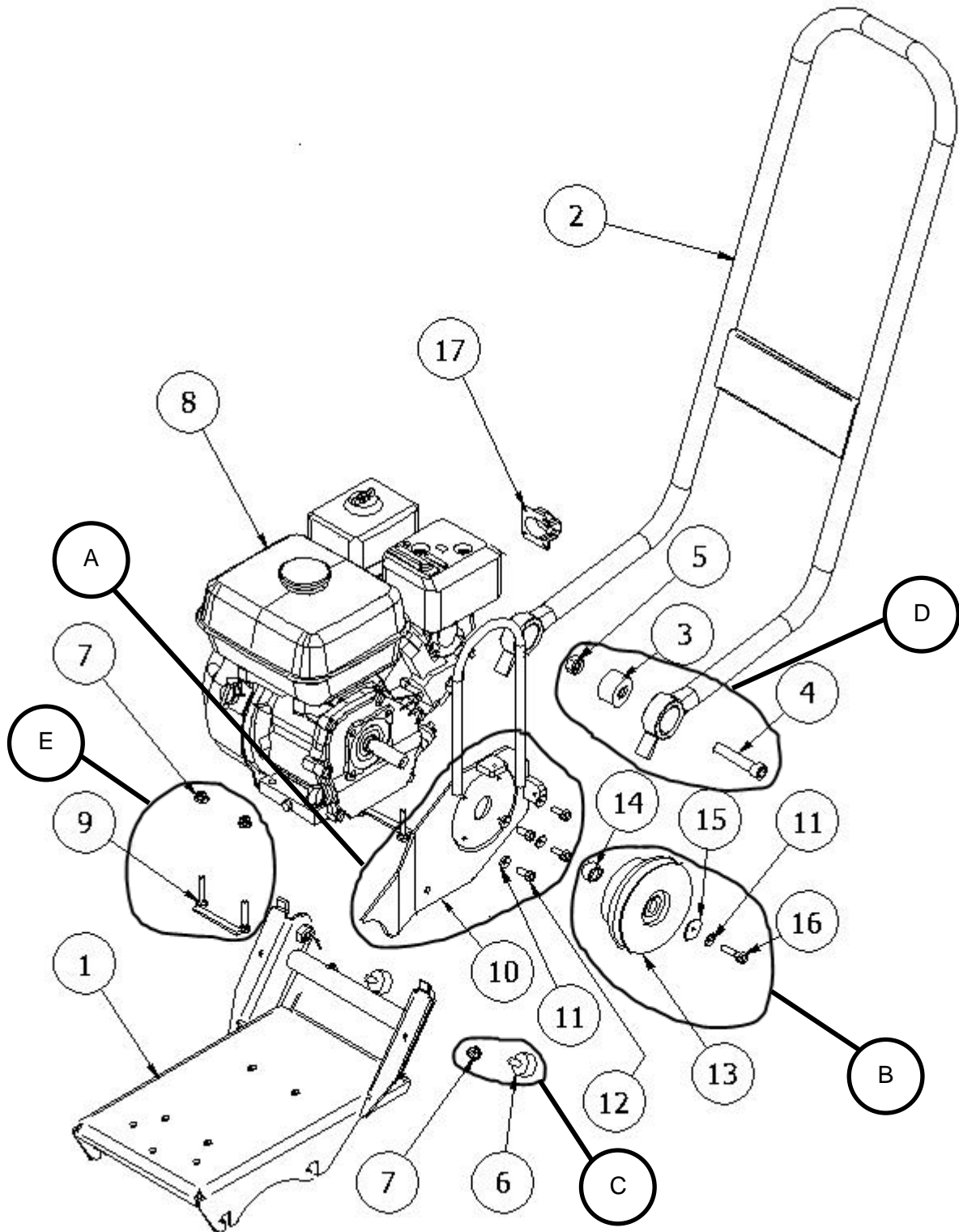

Engine support - Support moteur - Motor unterstützung						
POS.	DESCRIPTION	Description	Beschreibung	QTY	REF	Type
1	Engine support	Support moteur	Motorunterstützung	1	310576362	S
2	Handle	Poignée	Griff	1	310576363	S
3	HONDA GX 160 engine	Moteur HONDA GX 160	Motor HONDA GX 160	1	310544834	S
A	Belt protection support	Support de protection courroie	Riemengehäuseunterstützung	1	310576364	S
10	Belt protection support	Support de protection courroie	Riemengehäuseunterstützung	1		
11	Washer M8 ZN	Rondelle M8 Zn	Scheibe M8 Zn	4		
12	Screw TE 5/16-24X3/4" 8.8 UNF	Vis TE 5/16-24X3/4" 8.8 UNF	Schrauber TE 5/16-24X3/4" 8.8 UNF	4		
B	Centrifugal clutch kit	Kit embrayage centrifuge	Fliehkrafupplung Satz	1	310576365	S
11	Washer M8 ZN	Rondelle M8 Zn	Scheibe M8 Zn	1		
13	Centrifugal clutch 19.05 D136	Embrayage centrifuge 19.05 D136	Fliehkrafupplung 19.05 D136	1		
14	Pulley spacer	Entretoise poulie	Abstandhalter für eine Riemenscheibe	1		
15	Washer M8X32	Rondelle M8x32	Scheibe M8x32	1		
16	Screw TE 5/16-24 UNF -1"1/4 UNF	Vis TE 5/16-24 UNF -1"1/4 UNF	Schrauber TE 5/16-24 UNF -1"1/4 UNF	1		
C	Little shockmount	Petit silentblock	Klein Silentblock	1	310576387	W
6	Shockmount 30X20 M8X23	Silentblock 30X20 M8X23	Silentblock 30X20 M8X23	2		
7	Flanged bolt DIN 6923-M8	Ecrou DIN 6923-M8	Mutter DIN 6923-M8	2		
D	Shockmount	Silentblock	Silentblock	1	310544840	W
3	Shockmount D.43 60SH	Silentblock D43 60SH	Silentblock D43 60SH	2		
4	Screw TCEI M14X70 8.8 UNI 5931	Vis TCEI M14X70 8.8 UNI 5931	Schrauber TCEI M14X70 8.8 UNI 5931	2		
5	Bolt M14 UNI5588 ZN	BOLT M14 UNI5588 ZN	BOLT M14 UNI5588 ZN	2		
E	Clamp kit	Kit collier	Spannscheile Satz	1	310576597	S
9	Clamp	Collier	Spannscheile	1	310544847	S
7	Flanged bolt DIN 6923-M8	Ecrou DIN 6923-M8	Mutter DIN 6923-M8	2		
17	Deflector HONDA (BLACK)	Deflecteur HONDA (noir)	Deflektor HONDA (schwarz)	1	310543771	S

Complete view / Vue complète / Vollständigen Überblick

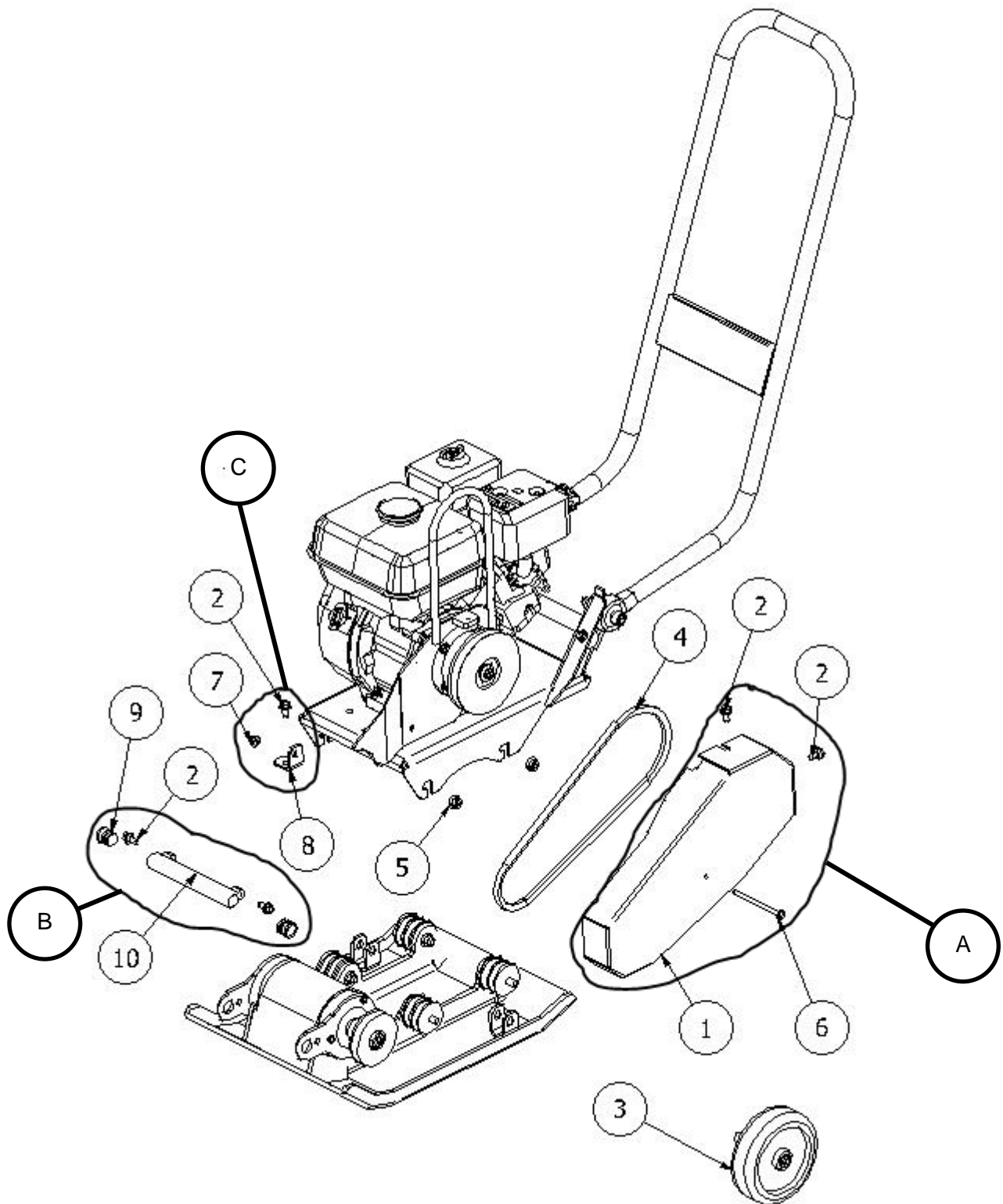

**Complete view - Vue complète - Vollständigen Überblick**

POS.	DESCRIPTION	Description	Beschreibung	QTY	REF	Type
<b>A</b>	<b>Belt protection</b>	<b>Carter Courroie</b>	<b>Riemengehäuse</b>	<b>1</b>	<b>310576388</b>	<b>S</b>
1	Belt protection	Carter Courroie	Riemengehäuse	1		
2	Screw FLG M8X16 8.8 ZN	Vis FLG M8X16 8.8 ZN	Schrauber FLG M8x16 8.8 ZN	2		
6	Screw TE M8X100	Vis TE M8X100	Schrauber TE M8X100	1		
<b>2</b>	<b>Belt A33 ½</b>	<b>Courroie A33 ½</b>	<b>Band A33 ½</b>	<b>1</b>	<b>310576389</b>	<b>W</b>
<b>3</b>	<b>Wheel with axle D.150</b>	<b>Roue avec axe D150</b>	<b>Rad mit einer Achse D150</b>	<b>1</b>	<b>310544861</b>	<b>W</b>
<b>B</b>	<b>Handle kit</b>	<b>Kit poignée</b>	<b>Griff Satz</b>	<b>1</b>	<b>310576390</b>	<b>S</b>
10	Handle	Poignée	Griff			
2	Screw FLG M8X16 8.8 ZN	Vis FLG M8X16 8.8 ZN	Schrauber FLG M8x16 8.8 ZN	2		
9	Cap D.25	Bouchon D25	Cap D25	2	310576598	S
<b>C</b>	<b>"L" support kit</b>	<b>Kit equerre</b>	<b>Eckwinckel Satz</b>	<b>1</b>	<b>310576391</b>	<b>S</b>
8	"L" Support	Equerre	Eckwinckel	1		
7	Flanged bolt M8	Ecrou DIN 6923-M8	Mutter DIN 6923-M8	1		
2	Screw FLG M8X16 8.8 ZN	Vis FLG M8X16 8.8 ZN	Schrauber FLG M8X16 8.8 ZN	1		

# Water tank/ Réservoir d'eau/ Wassertank

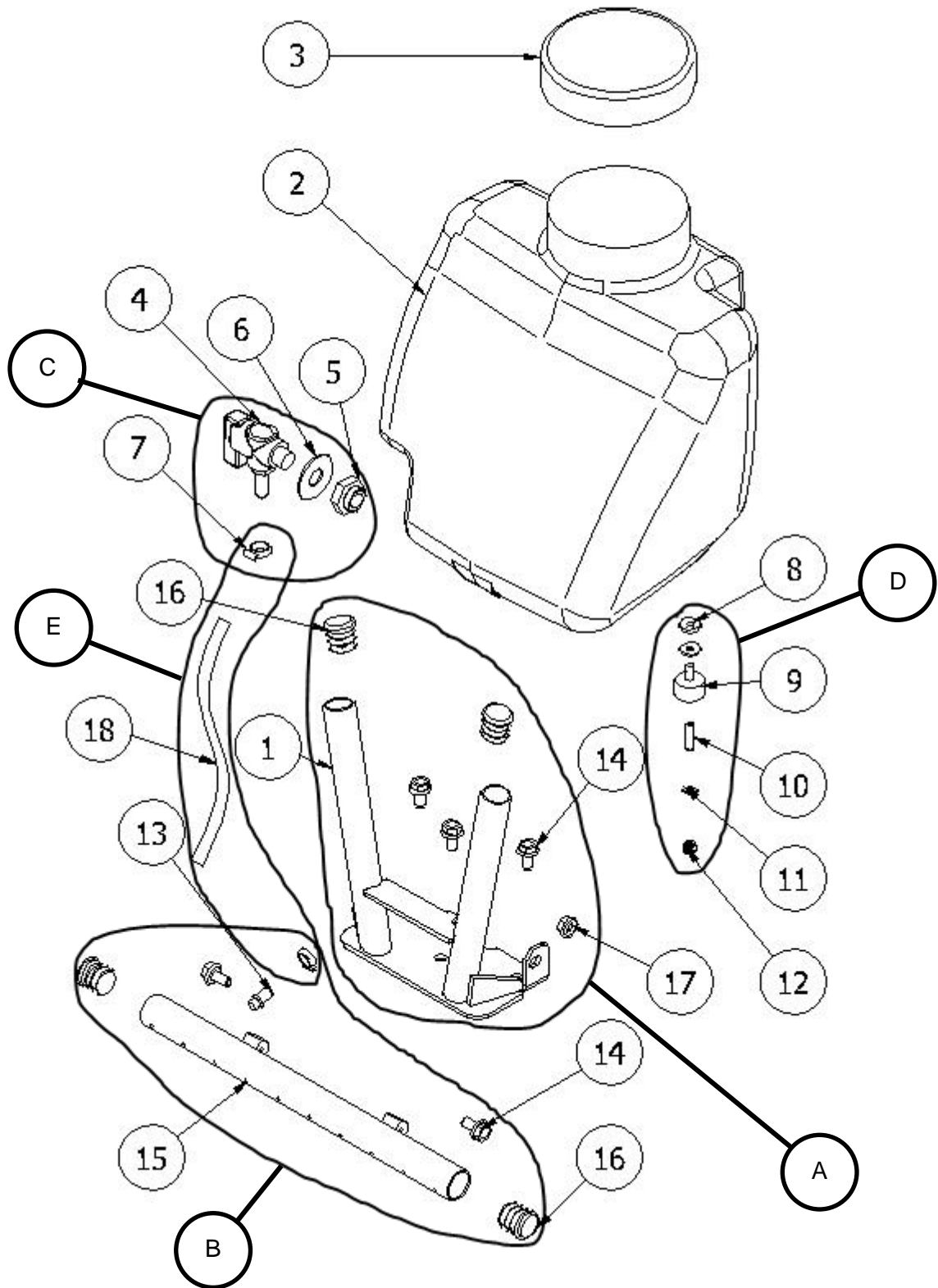

Water tank - Réservoir d'eau - Wassertank						
POS.	DESCRIPTION	Description	Beschreibung	QTY	REF	Type
<b>A</b>	<b>Water tank support kit</b>	<b>Kit support du réservoir</b>	<b>Wassertankunterstützung Satz</b>	<b>1</b>	<b>310576392</b>	<b>S</b>
1	Water tank support	Support du réservoir	Wassertankunterstützung	1		
14	Screw FLG M8X16 ZN	Vis FLG M8X16 ZN	Schrauber FLG M8X16 ZN	3		
16	Cap D.25	Bouchon D25	Cap D25	2	310576598	<b>S</b>
17	Flanged bolt M8	Ecrou DIN 6923-M8	Mutter DIN 6923-M8	1		
<b>2</b>	<b>Water tank 12 LT</b>	<b>Réservoir d'eau 12L</b>	<b>Wassertank 12Lt</b>	<b>1</b>	<b>310544863</b>	<b>S</b>
<b>3</b>	<b>Cap D. 113</b>	<b>Bouchon D113</b>	<b>Cap D113</b>	<b>1</b>	<b>310544864</b>	<b>S</b>
<b>B</b>	<b>Water sprinkling pipe kit</b>	<b>Kit nourrice d'arrosage</b>	<b>Wasserspender Satz</b>	<b>1</b>	<b>310576393</b>	<b>S</b>
16	Cap D.25	Bouchon D25	Cap D25	2	310576598	<b>S</b>
14	Screw FLG M8X16 ZN	Vis FLG M8X16 ZN	Schrauber FLG M8X16 ZN	2		
13	Rubber pipe connection 1/8"	Raccord de tuyau en caoutchouc 1/8"	Schlauchanschluss aus Gummi 1/8"	1		
15	Water sprinkling pipe	Nourrice d'arrosage	Wasserspender	1		
<b>C</b>	<b>Tap kit</b>	<b>Kit robinet</b>	<b>Wasserhahn Satz</b>	<b>1</b>	<b>310544815</b>	<b>W</b>
4	Tap	Robinet	Wasserhahn	1		
5	Bolt tap	Ecrou pour robinet	Mutter für Wasserhahn	1		
6	Washer tank	Rondelle réservoir	Wassertankscheibe	1		
7	Clamp D.12-20 ZN	Collier D12-20 ZN	Federscheibe D12-20 ZN	2		
<b>D</b>	<b>Shockmount</b>	<b>Silentblock</b>	<b>Silentblock</b>	<b>1</b>	<b>310544865</b>	<b>W</b>
8	Washer M6X18 ZN	Rondelle M6X18 ZN	Scheibe M6X18 ZN	2		
9	Shockmount MF D25X15 M6X12 60 SH	Silentblock MF D25X15 M6X12 60 SH	Silentblock MF D25X15 M6X12 60 SH	1		
10	Screw M6X25 ZN	Vis M6X25 ZN	Schrauber M6X25 ZN	1		
11	Washer M6 ZN	Rondelle M6 ZN	Scheibe M6 ZN	1		
12	Locking nut M6	Ecrou frein M6	Mutter M6	1		
<b>E</b>	<b>Rubber pipe</b>	<b>Tuyau en caoutchouc</b>	<b>Gummirohr</b>	<b>1</b>	<b>310576394</b>	<b>S</b>
18	Rubber pipe	Tuyau en caoutchouc	Gummirohr	0,25mt		
7	Clamp D.12-20 ZN	Collier D12-20 ZN	Federscheibe D12-20 ZN	2		

CFP 11 & CFP 11 W Stickers kit / kit autocollants CFP 11 & CFP 11 W / Aufkleber CFP 11 & CFP 11 W Satz



CRP 11 Stickers kit - Kit autocollants CRP 11 - Aufkleber CRP 11 Satz						
POS.	DESCRIPTION	Description	Beschreibung	QTY	REF	Type
1	Stickers kit CFP 11	Kit autocollants CFP 11	Aufkleber CFP 11 Satz	1	310576395	S
2	Stickers kit CFP 11 W	Kit autocollants CFP 11 W	Aufkleber CFP 11 W Satz	1	310576396	S



SAINT-GOBAIN ABRASIVES  
 INDUSTRIEWEG 21  
 9420 ERPE-MERE  
 BELGIUM  
 TEL: +32(0) 2 267 21 00

SAINT-GOBAIN CONSTRUCTION PRODUCTS  
 CZ A.S  
 DIVIZE ABRASIVES  
 SMRČKOVA 2485/4  
 180 00 PRAHA 8  
 CZECH REPUBLIC  
 TEL: +420 255 719 326  
 FAX: +420 255 719 321

SAINT-GOBAIN ABRASIVES A/S  
 DYBENDALSVÆNGET 2,  
 DK-2630 TAASTRUP  
 DENMARK  
 TEL: +45 4675 5244

PO BOX 643706  
 FORTUNE TOWER OFFICE 2106  
 JLT BLOCK C  
 (NEXT TO METRO STATION)  
 JUMEIRA LAKE TOWER, DUBAI  
 UNITED ARAB EMIRATES  
 TEL: +971 4 431 5154  
 FAX: +971 4 431 5434

SAINT-GOBAIN ABRASIFS  
 RUE DE L'AMBASSADEUR - B.P.8  
 78 702 CONFLANS CEDEX  
 FRANCE  
 TEL: +33 (0)1 34 90 40 00  
 FAX: +33 (0)1 39 19 89 56

SAINT-GOBAIN ABRASIVES GMBH  
 BIRKENSTRASSE 45-49  
 D-50389 WESSELING  
 GERMANY  
 TEL: +49 (0) 2236 703-0  
 FAX: +49 (0) 2236 703-730

SAINT-GOBAIN ABRASIVES KFT.  
 1225 BUDAPEST  
 BÁNYALÉG U. 60/B.  
 HUNGARY  
 TEL: +36 1 371 22 50  
 FAX: +36 1 371 22 55

SAINT-GOBAIN ABRASIVI S.P.A  
 VIA PER CESANO BOSCONI 4  
 I-20094 CORSICO MILANO  
 ITALY  
 TEL: +39 02 44 851  
 FAX: +39 02 44 78 266

SAINT-GOBAIN ABRASIVES S.A.  
 190 RUE J.F. KENNEDY  
 L-4930 BASCHARAGE  
 GRAND DUCHE DE LUXEMBOURG  
 TEL: +352 50 401 1  
 FAX: +331 83 717 792  
 NO. VERT (FRANCE): 0800 906 903

SAINT-GOBAIN ABRASIFS, S.A.  
 2 ALLÉE DES FIGUIERS  
 AIN SEBAË - CASABLANCA  
 MOROCCO  
 TEL: +212 5 22 66 57 31  
 FAX: +212 5 22 35 09 65

SAINT-GOBAIN ABRASIVES BV  
 GROENLOSEWEG 28  
 7151 HW EIBERGEN  
 P.O. BOX 10  
 7150 AA EIBERGEN  
 THE NETHERLANDS  
 TEL: +31 545 466466  
 FAX: +31 545 474605

SAINT-GOBAIN ABRASIVES AS  
 KARIHAUGVEIEN, 89  
 0186 OSLO  
 NORWAY  
 TEL: +47 63 87 06 00  
 FAX: +47 63 87 06 01

SAINT-GOBAIN HPM POLSKA SP. Z O.O.  
 UL. NORTON 1, 62-600 KOŁO  
 62-600 KOŁO  
 POLAND  
 TEL: +48 63 26 17 100  
 FAX: +48 63 27 20 401

SAINT-GOBAIN ABRASIVOS, L. DA  
 ZONA INDUSTRIAL DA  
 I-SECTOR VIII, NO. 122  
 APARTADO 6050  
 4476 - 908 MAIA  
 PORTUGAL  
 TEL: +351 229 437 940  
 FAX: +351 229 437 949

SAINT-GOBAIN GLASS  
 BUSINESS UNIT ABRASIVI  
 PUNCT DE LUCRU : LOC.VETIS, JUD.  
 SATU MARE 447355  
 STR. CAREIULUI 11  
 PARC INDUSTRIAL RENOVATIO  
 ROMANIA  
 TEL: +40 261 839 709  
 FAX: +40 261 839 710

SG HPM RUS  
 58, F. ENGELS STR.  
 STROENIE 2  
 105082 MOSCOW  
 RUSSIA  
 TEL: +74 955 408 355  
 FAX: +74 959 373 224

SAINT-GOBAIN  
 ABRASIVES (PTY) LTD  
 2 MONTEER ROAD  
 ISANDO 1600  
 P.O. BOX 67  
 SOUTH AFRICA  
 TEL: +27 11 961 2000  
 FAX: +27 11 961 2184/5

SAINT-GOBAIN ABRASIVOS, S.A.  
 CTRA. DE GUIPÚZCOA, KM. 7,5  
 E-31195 BERRIOPLANO (NAVARRA)  
 SPAIN  
 TEL: +34 948 306 000  
 FAX: +34 948 306 042

SAINT GOBAIN ABRASIVES AB  
 GÅRDSFOGDEVÄGEN 18A  
 168 66 BROMMA • SVERIGE  
 SWEDEN  
 TEL: +46 8 580 881 00  
 FAX: +46 8 580 881 30

SAINT-GOBAIN INOVATIF MALZEMELER VE  
 ASINDIRICI SAN. TIC. AS.  
 ALTAYÇEŞME MAH. ÇAMLI SOK. NO:21 ESAS  
 OFISPARK KAT:9 34843  
 MALTEPE, İSTANBUL • TURKEY  
 TEL: 0090-216-217 12 50  
 FAX: 0090-216-442 40 74

SAINT-GOBAIN ABRASIVES LTD.  
 UNICORN HOUSE UNIT 1, AMISON CLOSE  
 REDHILL BUSINESS PARK  
 STAFFORD ST161WB  
 UNITED KINGDOM  
 TEL: +44 1785 279 553  
 FAX: +44 1785 213 487



Saint-Gobain Abrasifs  
 190 Rue J.F. Kennedy  
 L-4930 Bascharage  
 Grand Duche de Luxembourg  
 Tel: +352 50 401 1  
 Fax: +331 83 717 792  
 no. vert (France) 0800 906 903