

# CG 252

## OPERATING INSTRUCTIONS

Translation of the original instructions



**NORTON**  
SAINT-GOBAIN®

**clipper®**





The undersigned manufacturer:

**SAINT - GOBAIN ABRASIVES S.A.  
190, BD. J. F. KENNEDY  
L-4930 BASCHARAGE**

Declares that this product:

Grinding machine : **CG 252**

Code : **70184694290**

is in conformity with the following Directives:

- **"MACHINES" 2006/42/CE**
- **"ELECTROMAGNETIC COMPATIBILITY" 2014/30/UE**
- **"NOISE" 2000/14/CE**

Valid for machines as of serial number:

1411000000

Storage site for the technical documents :

Saint-Gobain Abrasives 190, Bd. J. F. Kennedy 4930 BASCHARAGE, LUXEMBOURG

This declaration of conformity loses its validity when the product is converted or modified without agreement.

Bascharage, Luxembourg, 18.10.2024.

A handwritten signature in black ink, appearing to read 'Genuardi', with a long horizontal stroke extending to the right.

Fabrice Genuardi, executive officer.



# CG 252 : OPERATING INSTRUCTIONS

## TABLE OF CONTENTS

<b>1</b>	<b>BASIC SAFETY INSTRUCTIONS</b>	<b>6</b>
1.1	<i>Symbols</i>	6
1.2	<i>Machine plate</i>	6
1.3	<i>Safety instructions for particular operating phases</i>	7
<b>2</b>	<b>MACHINE DESCRIPTION</b>	<b>8</b>
2.1	<i>Short description</i>	8
2.2	<i>Purpose of use</i>	8
2.3	<i>Technical Data</i>	10
2.4	<i>Statement regarding the vibration emission</i>	11
2.5	<i>Statement regarding noise emission</i>	12
<b>3</b>	<b>ASSEMBLY AND COMMISSIONING</b>	<b>13</b>
3.1	<i>Tool assembly</i>	13
3.2	<i>Establishment of connections</i>	13
3.3	<i>Establishment of the dust extractors.</i>	13
3.4	<i>Establishment of the water supply</i>	13
3.5	<i>Starting the machine</i>	13
<b>4</b>	<b>TRANSPORT AND STORAGE OF THE MACHINE</b>	<b>14</b>
4.1	<i>Security for transport</i>	14
4.2	<i>Transport procedure</i>	14
4.3	<i>Storage of machine</i>	14
<b>5</b>	<b>OPERATING THE MACHINE</b>	<b>15</b>
5.1	<i>Site of work</i>	15
5.2	<i>Specific Adjustment of the machine</i>	15
5.3	<i>Polishing and preparation of the ground with the CG 252</i>	18
<b>6</b>	<b>MAINTENANCE AND SERVICING</b>	<b>19</b>
<b>7</b>	<b>FAULTS : CAUSES AND CURES</b>	<b>20</b>
7.1	<i>Fault-finding procedures</i>	20
7.2	<i>Trouble-shooting guide</i>	20
7.3	<i>Circuit diagram</i>	20
7.4	<i>Customer service</i>	21

# 1 BASIC SAFETY INSTRUCTIONS

The CG 252 is exclusively destined for the polishing and the preparation of the ground with NORTON polishing and surfacing tools, mainly on construction sites.

Uses other than the manufacturer's instructions shall be considered as contravening the regulations. The manufacturer shall not be held responsible for any resulting damage. Any risk shall be borne entirely by the user. Observing the operating instructions and compliance with inspection and servicing requirements shall also be considered as included under use in accordance with the regulations.

## 1.1 Symbols

The advice and warnings are represented by pictograms on the machine. You will find the following symbols on the machines NORTON. Here is their explanation:



The meanings of these symbols are:

- Hearing Protection mandatory
- Safety glasses with side protection mandatory
- CE marking of the machine
- Safety Shoes mandatory
- Read the Handbook is mandatory before using the machine

## 1.2 Machine plate

Important data can be found on the following plate located on the machine :

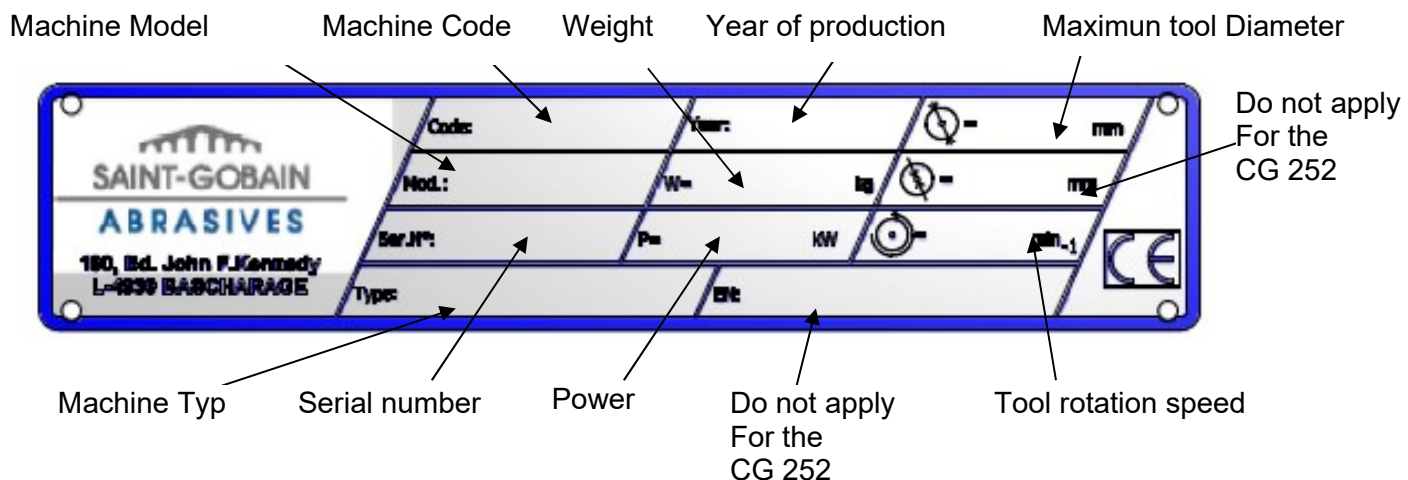

### **1.3 Safety instructions for particular operating phases**

#### **Before commencing work**

- Read the present operator's instructions booklet carefully.
- Familiarize yourself with the environment at the place of intervention. This work environment includes, for example, the difficulties of execution, the obstacles to the movement, respect for floor loads, security marking necessary delimiting the construction site by report to the public traffic and the possibility of intervention of emergency in case of accident.
- Regularly check if the disks of polishing or surfacing are fixed correctly.
- Unmount immediately the tools of polishing or surfacing deformed or damaged, because they pose a risk of accident during the rotation.
- Regularly check the flexible coupling because its life is directly related to the conditions of use of the machine.
- Only use the machine with its protective casings and its covers for the electrical box fixed.
- Verify that the protective casing slides vertically and freely.  
When using the machine the protective casing must always be in contact with the ground.
- For a dry use only use the machine with a dust extractors. (A nozzle is provided for this purpose)
- Check that all hoses (suction and water supply) are not damaged and properly connected.
- Please wear safety glasses when working.
- Only use tools polishing or surfacing NORTON. The use of other tools may result in damage to the machine.
- Do not leave the machine resting on the tool or on the flexible coupling when she's not in use, this would cause the premature deformation of the flexible coupling.  
Chock in this case the machine on the handle.
- !!! Never use the machine in the rain !!!

#### **Machine with electric motor**

Turn off the power supply to the CG 252 and separate it from the network before any operation on the machine.

- Avoid contact of the electrical connections with the projections of water or moisture.
- The CG 252 absolutely must be correctly connected to the earth. In case of doubt, made Check the electrical connections by a qualified electrician.
- In case of emergency you can stop the machine by pressing the button "Red" stop of the electric box.
- If the CG 252 stops without apparent reason, turn off the main supply power in electricity of the machine. Only a qualified electrician is empowered to investigate and resolve the problem.

## 2 MACHINE DESCRIPTION

Any modification to the machine which can altering these initial properties can be carried out only by Saint-Gobain abrasive, only one to confirm the conformity of the product. Saint-Gobain Abrasive retains the right to make any technical change or the design of the machine without prior notification.

### 2.1 Short description

The polisher grinder CG 252 is designed for the preparation of small and medium surfaces. Robust and powerful Machine, she can be used on construction sites, but also in industrial environment.

### 2.2 Purpose of use

The CG 252 is designed for the preparation of soils (sanding, preparation before installing coating, rectification, deletion of irregularities or glues etc...). she's designed for no other use.

Overview of the components

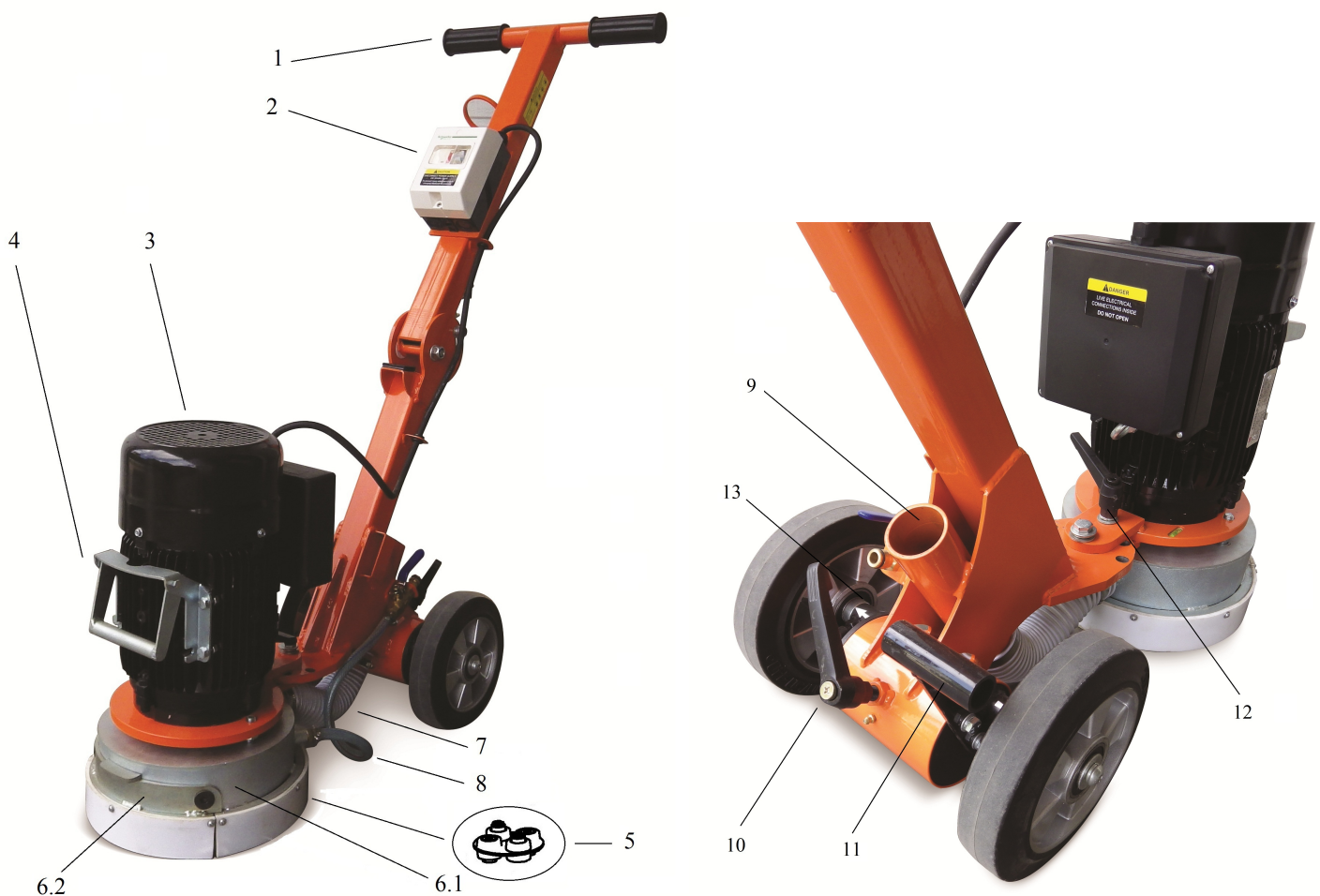

**Handle of use and arm (1)**

Rigid construction in welded steel.

The angle of the arm can be adjusted to guarantee a comfortable use.

**Enclosure to On/Off Button (2)**

This unit is made up of start buttons (Black) / Stop (red) which allow start and stop the machine. The stop button (red) is an emergency stop button.

**Electric motor (3)**

Electric Motor 230V 1~ / 2,2kW.

**Lifting Handle (4)**

The lifting handle allows you to lift the machine by hand.

**Flexible Coupling (5)**

The flexible coupling is a vital part of the machine it ensures the connection between the engine and the polishing or surfacing tool.

**Protective casing (6.1)**

The protective casing sliding protects the operator from the rotation of the polishing or surfacing tools, while giving him an optimal view on the advance of his work.

**Removable protective casing (6.2)**

This protective casing is removable to allow work in a flush to the wall.

**Suction Hose (7)**

Hose for dust extraction.

**Hose for supply in water (8)**

Hose for supply in water.

**Connection nozzle for dust extractors (9)**

This nozzle allows you to connect a dust extractors CLIPPER during a dry use.

**Indexable lever to tilt the machine (10)**

This lever allows you to release the handle allowing the inclination of the machine.

**Handle tilt of the machine (11)**

Turn the handle to adjust the tilt angle of the machine according to your needs.

**Indexable Lever for the rotation of the head (12)**

This lever allows you to release the front head of the machine for rotate it, when you need to use it in a flush to the wall

**Adjustment of the rear track of the machine (13)**

This setting allows you to widen the rear track depending on the needs for better stability.

**2.3 Technical Data**

Electric motor	2,2 kW / 3HP / 230V 1~
Electric motor protection	IP54
Maximun tool Diameter (Discs)	250mm
Rotation speed of the output shaft of the reducer	1410 Tr.min <sup>-1</sup>
Sound level	79 dB (A) (according to ISO EN 11201)
Sound Power Level	91 dB (A) (according to ISO EN 3744)
Typ of tool	Polishing or surfacing tool
Machine Dimensions unfolded (LxWxH)	1180x420x1120mm
Machine Dimensions folded (LxWxH)	800x420x860mm
Weight (with tool assembled)	60 kg

## 2.4 Statement regarding the vibration emission

Declared value of vibration emission following **EN 12096, EN ISO 20643 and EN ISO 5349.**

Machine Model / code	Measured value of vibration emission at m/s <sup>2</sup>	Uncertainty K m/s <sup>2</sup>	Tool used Model / code
<b>CG 252</b> 70184694290	<2.5	0.5	Diamond plates GRD25 S MEDIUM Green 70184627119

- The vibration value is lower and does not exceed 2.5 m/s<sup>2</sup>.
- The measurements are made with new machines. Actual values may vary with site conditions, in terms of:
  - Materials worked
  - Wear Machine
  - Lack of maintenance
  - Inappropriate tool for application
  - Tool in poor condition
  - Unskilled operator
  - Etc...
- The exposure time to vibration is based on the performance of work (related to the adequacy Machine / Tool / worked material / operator)
- When evaluating risks due to hand-arm vibration, you need to take into account effective usage at rated power of machine during a full day of work; quite often you will realise that effective utilisation time represents around 50% of overall duration of work. You have to consider, of course, breaks, water feeding, preparation of work, time to move the machine, disk mounting...

## 2.5 Statement regarding noise emission

Declared value of noise emission following **EN ISO 11201** and **NF EN ISO 3744**.

Machine Model / code	Sound Pressure level $L_{Peq}$ EN ISO 11201	Uncertainty K (Sound Pressure level $L_{Peq}$ EN ISO 11201)	Sound power level $L_{Weq}$ NF EN ISO 3744	Uncertainty K (Sound power level $L_{Weq}$ NF EN ISO 3744)
<b>CG 252</b> 70184694290	79 dB(A)	2.5 dB(A)	91 dB(A)	4 dB(A)

- The measurements are made with new machines. Actual values may vary with site conditions, in terms of:
  - Wear Machine
  - Lack of maintenance
  - Inappropriate tool for application
  - Tool in poor condition
  - Unskilled operator
  - Etc...
  
- Measured values relate to an operator in normal use, as described in the manual position.

### **3 ASSEMBLY AND COMMISSIONING**

The machine is delivered assembled, fully equipped and ready for use. Before using the machine for the first time, follow these simple instructions.

#### **3.1 Tool assembly**

Only use tools NORTON. The machine can be used with tools of types: discs, wings. Turn off the power of the machine and unplug there of the electrical network prior to install or change a tool. The maximum diameter of tools supported by the machine is 250mm. To mount a tool, lay the machine so for it rests on its sleeve. (Handle to the ground). Make sure that the machine will not tip, then mount and tighten your tool.

#### **3.2 Establishment of connections**

Check that :

- The button "start" (Black) to start is not activated.
- The supply voltage and the current type correspond to those of the machine.
- Grounding is regulatory.
- The power cable is at least 2.5 mm<sup>2</sup> of section by phase.

#### **3.3 Establishment of the dust extractors.**

During a dry use always use the machine with a dust extractors. A nozzle of connecting at the level of the frame is provided for this purpose. You simply connect the dust extractors on this nozzle.

#### **3.4 Establishment of the water supply**

A nozzle of connection is provided for a use at the water. You simply connect your arrival of water on this nozzle. A valve is located downstream of this nozzle to regulate the flow.

#### **3.5 Starting the machine**

- Turn the guide arm in a comfortable position. To do this, loosen the screw on the articulation of the arm, turn the arm to the desired angle, and tighten the screw.
- Then, adjust the wheel spacing of the rear track according to your needs.
- For a dry use, always use a dust extractors.
- Connect the pipe of the dust extractors to the machine nozzle provided for this purpose, then start the dust extractors before starting the machine.
- For use with water, open the valve located on the machine to regulate your flow.
- You can also connect a dust extractors for a used at the water. To do this connect the pipe to the dust extractors to the machine nozzle provided for this purpose, and then start the dust extractors before starting the machine.
- Stay behind the machine and then lift the machine off the ground and assuring you that the polishing or surfacing tool isn't in contact with the ground. Make sure that the protective casing remains in contact with the ground.
- To start the machine, press the button "start" (black).
- Start the job by lowering the machine until the tool work effectively on the ground.
- To stop the machine, press the button "Stop" (red).
- Unplug the machine from the electrical network and wait for the complete shutdown of the work tool.
- Turn off the dust extractors and or the water valve.

## **4 TRANSPORT AND STORAGE OF THE MACHINE**

### **4.1 *Security for transport***

Always disassemble the tool of polishing or surfacing before the transport or movement of the machine.

### **4.2 *Transport procedure***

Conform yourself to work regulations, in order to transport the machine. The machine is not designed to be lifted with a crane.

A carrying handle is provided, for the manual transport.

### **4.3 *Storage of machine***

If the machine is not going to be used for a long period, completely clean the machine and disassemble the tool of polishing or surfacing. The storage site must be clean, dry and at a constant temperature.

## 5 OPERATING THE MACHINE

In this section you will find tips for using the machine safely.

### 5.1 *Site of work*

- Remove from the site anything, which might hinder the working procedure!
- Make sure the site is sufficiently well lit!
- Observe manufacturer's conditions for connecting to power supplies!
- Place the electrical cables, the water pipe so as to avoid the possibility of fall and damage.
- Make sure you have a continual adequate view of the working area so you can intervene in the working process at any time!
- Keep other staff out of the area, so you can work securely.

### 5.2 *Specific Adjustment of the machine*

- To adjust the pressure and the attack of the tools on the ground, you can simply loosen the indexable joystick and turn the handle then adjust the position of the axis according to your needs (see photo below).



- To adjust the spacing of the wheels of the rear track of the machine it you simply loosen the screw at the level of the axis of the wheel with the key provided with the machine. Then adjust the spacing according to your needs for a better stability (see photo below).

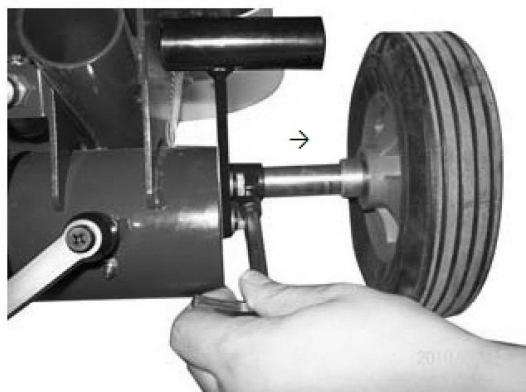

- The machine offers a possibility of easy maneuvering by twisting the head of polishing following the desired angle.

To do this loosen the indexable joystick (1) then rotate the head to the desired angle depending on the index holes available (2).

The good chosen position, tighten the indexable joystick (1) (see photos below).

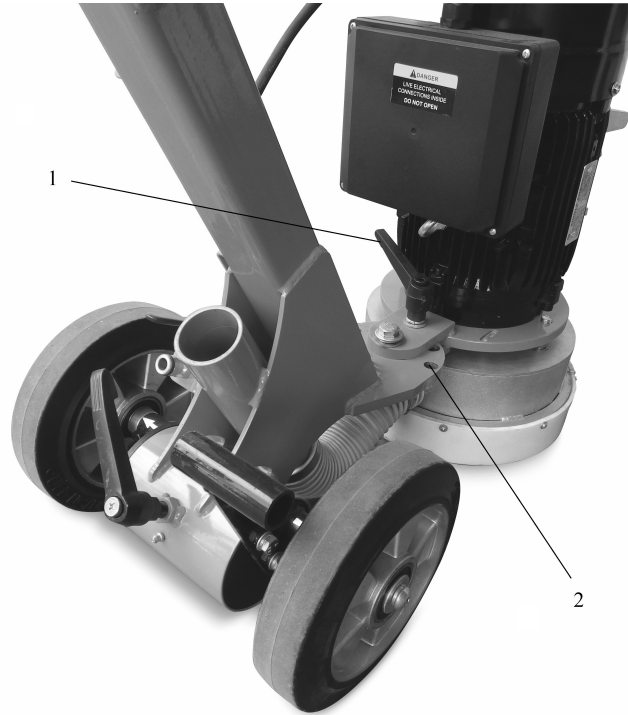

- When a job in a flush to the wall is necessary so you can rotate the head to the desired angle, but you must also remove the removable cover (3) via its two mounting screws (see photos below), a surplus of dust is possible.



- !!! Warning, danger !!! :

When a used in a flush to the wall , removable casing protective removed, all person must stand behind the machine for security!!! All person not complying with this setpoint is exposed to a risk and will be in danger.



Machine without removable protective casing

### 5.3 *Polishing and preparation of the ground with the CG 252*

- To use the CG 252 properly, you must stand behind the machine, taking the two handles.
- To start the machine, press the button "start" (black).
- To stop the machine, press the button "Stop" (red).
- To get an optimal result during the work of the machine, the machine must not stagnate in a point, on the contrary, it must be in perpetual motion following the diagram recommended below:

#### **Machine Guidance**

Move the machine from left to right and from the front toward the rear.

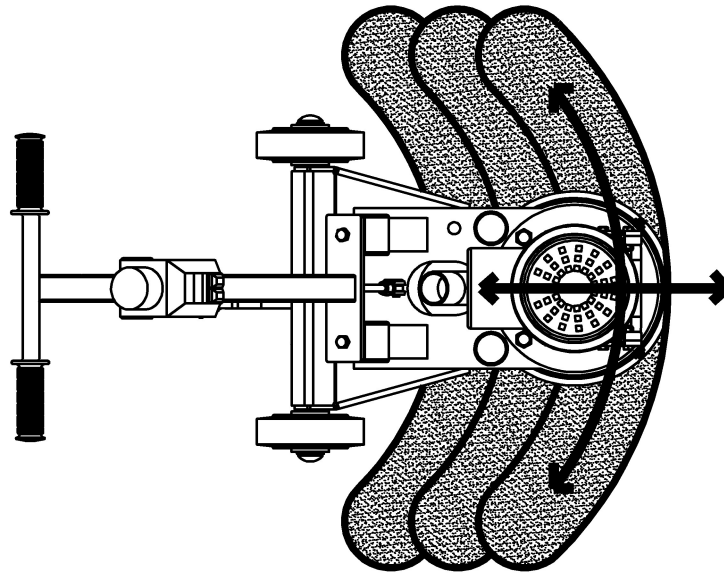

**NOTE:** never leave the machine to turn in continuous on the same place under penalty of degrade seriously the ground.

**WARNING:** after the extinction of the machine, the tool continuous to turn up to his full stop. So, be vigilant to avoid any injury.

## 6 MAINTENANCE AND SERVICING

In order to maintain a quality in time, during the preparation of your floors and for a safe operation and without any problems of the machine, please follow the maintenance plan below:

		Begin of the day	During the changing of tool	End of the day or more often if required	Every week	After a fault	After a damage
Machine assembly	Contrôle visuel (état général, étanchéité)						
	Clean						
Tool and removable casing	Clean						
Motor cooling fan	Clean						
Motor housing	Clean						
Reachable nuts and screws	Tighten up						

### Maintenance of the machine

Always perform the maintenance of the machine with the machine isolated from the electrical supply and with tools idle.

### Lubrication

The NORTON machines are equipped with bearings lubricated for life. It is therefore unnecessary to grease or oil the machine, except the places fitted with a grease fitting.

### Check and change of the flexible coupling

To check the condition of the flexible coupling you can simply proud you to the wear of your tool. If you notice a wear not uniform on the tool (part of beveled tool), see traces more pronounced on your ground it may be time to replace the flexible coupling.

In effect this are the first causes directly related to the wear of the flexible coupling.

To change the flexible coupling disconnects the machine from the electrical network and then chock the machine to the change tool position (section 3.1).

Disassemble the tool in loosening the appropriate screws, and then remove the protective casings and loosen the screws of the bracket plate and of the flexible coupling.

Replace then with a new flexible coupling, and then reassemble the while taking care to reassemble the protective casings while checking their proper functioning.

### Cleaning of the machine

Your machine will last longer if you clean it thoroughly after each day of work.

## 7 FAULTS : CAUSES AND CURES

### 7.1 *Fault-finding procedures*

Should any fault occur during the use of the machine, turn it off, and isolate it from the electrical supply. Any works dealing with the electrical system or supply of the machine can only be carried out by a qualified electrician.

### 7.2 *Trouble-shooting guide*

Panne	Source possible	Résolution
The engine is not running when the button "Start" (black) is pressed.	No electricity	Check the electrical supply (fuse for example)
	Connection cable section too small	Change connection cable
	Defective switch	CAUTION : can only be solved by qualified electrician
	Defective motor	Change motor or contact motor manufacturer
	Defective connection cable	Change connection cable

### 7.3 *Circuit diagram*

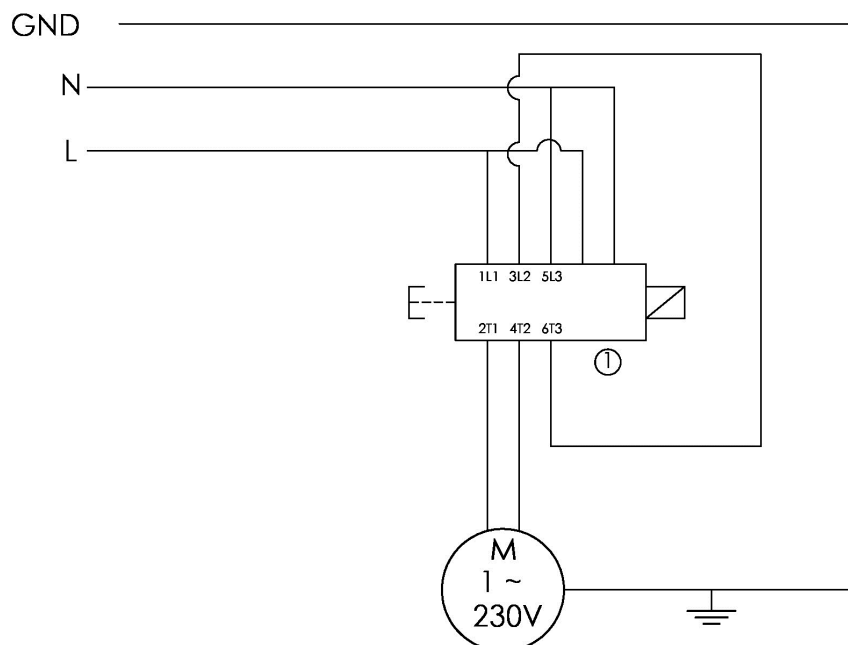

1 : Control Box

## **7.4 Customer service**

The spare parts list is available on the website: <http://www.construction.norton.eu>

When ordering spare parts, please mention:

1. The serial number
2. The code of the part.
3. The exact denomination.
4. The number of parts required.
5. The delivery address.
6. Please indicate clearly the means of transportation required such as "express" or "by air".  
Without specific instructions, we will forward the parts through the means which seem appropriate to us --- but which is not always the quickest way.

Clear instructions will avoid problems and faulty deliveries.

If not sure, please send us the defective part. In the case of a warranty claim, the part must always be returned for evaluation. Order the spare parts of the motor directly to the manufacturer or among a representative.

This machine has been manufactured by Saint-Gobain Abrasives S.A.:

190, Bd. J.F.Kennedy  
L-4930 BASCHARAGE  
Grand-Duché de Luxembourg  
Tel. : 00352 50 401 1  
Fax. : 00352 50 16 63  
<http://www.construction.norton.eu>  
e-mail : [sales.nlx@saint-gobain.com](mailto:sales.nlx@saint-gobain.com)

Guarantee can be claimed and technical support obtained from your local distributor where machines, spare parts and consumables can be ordered as well:

SAINT-GOBAIN ABRASIVES NV/SA  
INDUSTRIELAAN 129  
1070 ANDERLECHT /BRUSSEL  
BELGIUM  
TEL: +32 (0)2 267 21 00  
FAX: +32 (0)2 267 84 24

SAINT-GOBAIN ABRASIVES, S.R.O.  
VINOHRADSKÁ 184  
130 52 PRAHA 3  
CZECH REPUBLIC  
TEL: +420 267 132 026  
+420 267 132 029  
FAX: +420 267 132 021-2

SAINT-GOBAIN ABRASIVES A/S  
ROBERT JACOBSENS VEJ 62A  
2300 KØBENHAVN S  
DENMARK  
TEL: +45 4675 5244

PO BOX 643706  
FORTUNE TOWER OFFICE 2106  
JLT BLOCK C  
(NEXT TO METRO STATION)  
JUMEIRA LAKE TOWER, DUBAI  
UNITED ARAB EMIRATES  
TEL: +971 4 431 5154  
FAX: +971 4 431 5434

SAINT-GOBAIN ABRASIFS  
RUE DE L'AMBASSADEUR - B.P.8  
78 702 CONFLANS CEDEX  
FRANCE  
TEL: +33 (0)1 34 90 40 00  
FAX: +33 (0)1 39 19 89 56

SAINT-GOBAIN ABRASIVES GMBH  
BIRKENSTRASSE 45-49  
D-50389 WESSELING  
GERMANY  
TEL: +49 (0) 2236 703-1  
+49 (0) 2236 8996-0  
+49 (0) 2236 8911-0  
FAX: +49 (0) 2236 703-367  
+49 (0) 2236 8996-10  
+49 (0) 2236 8911-30

FÜR DEN FACHHANDEL  
ÖSTERREICH  
TEL: +43 (00) 662 430 076

SAINT-GOBAIN ABRASIVES KFT.  
1225 BUDAPEST  
BÁNYALÉG U. 60/B.  
HUNGARY  
TEL: +36 1 371 22 50  
FAX: +36 1 371 22 55

SAINT-GOBAIN ABRASIVI S.P.A  
VIA PER CESANO BOSCONI 4  
I-20094 CORSICO MILANO  
ITALY  
TEL: +39 02 44 851  
FAX: +39 02 44 78 266

SAINT-GOBAIN ABRASIVES S.A.  
190 RUE J.F. KENNEDY  
L-4930 BASCHARAGE  
GRAND DUCHE DE LUXEMBOURG  
TEL: +352 50 401 1  
FAX: +352 50 16 33  
NO. VERT (FRANCE) 0800 906 903

SAINT-GOBAIN ABRASIFS, S.A.  
2 ALLÉE DES FIGUIERS  
AIN SEBAË - CASABLANCA  
MOROCCO  
TEL: +212 5 22 66 57 31  
FAX: +212 5 22 35 09 65

SAINT-GOBAIN ABRASIVES BV  
GROENLOSEWEG 28  
7151 HW EIBERGEN  
P.O. BOX 10  
7150 AA EIBERGEN  
THE NETHERLANDS  
TEL: +31 545 466466  
FAX: +31 545 474605

SAINT-GOBAIN ABRASIVES AS  
POSTBOKS 11, ALNABRU,  
0614 OSLO  
BROBEKKVEIEN 84,  
0582 OSLO  
NORWAY  
TEL: +47 63 87 06 00  
FAX: +47 63 87 06 01

SAINT-GOBAIN HPM POLSKA SP. Z O.O.  
UL. TORUŃSKA 239/241  
62-600 KOŁO  
POLAND  
TEL: +48 63 26 17 100  
FAX: +48 63 27 20 401

SAINT-GOBAIN ABRASIVOS, L. DA  
ZONA INDUSTRIAL DA MAIA  
I-SECTOR VIII, NO. 122  
APARTADO 6050  
4476 - 908 MAIA  
PORTUGAL  
TEL: +351 229 437 940  
FAX: +351 229 437 949

SAINT-GOBAIN ABRASIVI SRL  
PARC INDUSTRIAL HOLROM  
DRUM CAREI NR. 11  
447355 VETIS JUD. SATU-MARE  
ROMANIA  
TEL: +40 261 450 009  
FAX: +40 261 750 010

SG HPM RUS  
58, F. ENGELS STR.  
STROENIE 2  
105082 MOSCOW  
RUSSIA  
TEL: +74 955 408 355  
FAX: +74 959 373 224

SAINT-GOBAIN  
ABRASIVES (PTY) LTD  
2 MONTEER ROAD  
ISANDO 1600  
P.O. BOX 67  
SOUTH AFRICA  
TEL: +27 11 961 2000  
FAX: +27 11 961 2184/5

SAINT-GOBAIN ABRASIVOS, S.A.  
CTRA. DE GUIPÚZCOA, KM. 7,5  
E-31195 BERRIOPLANO (NAVARRA)  
SPAIN  
TEL: +34 948 306 000  
FAX: +34 948 306 042

SAINT-GOBAIN ABRASIVES AB  
BOX 495  
SE-191 24 SOLLENTUNA  
SWEDEN  
TEL: +46 8 580 881 00  
FAX: +46 8 580 881 01

SAINT-GOBAIN ABRASIVES  
MUEYYETZADE MAH.  
GALIPDEDE CAD. NO:99, KAT:3  
34425 BEYOGLU-ISTANBUL-  
TURKEY  
TEL: 0090-212-245 85 21  
FAX: 0090-212-245 85 27

SAINT-GOBAIN ABRASIVES LTD.  
DOXEY RD  
STAFFORD  
ST16 1EA  
UNITED KINGDOM  
TEL: +44 1785 222 000  
FAX: +44 1785 213 487



[www.construction.norton.eu](http://www.construction.norton.eu)

**Saint-Gobain Abrasives**

190, Bd. J. F. Kennedy  
L-4930 BASCHARAGE  
LUXEMBOURG

Tel: ++352 50401-1

Fax: ++352 501633

e-mail: [sales.nlx@saint-gobain.com](mailto:sales.nlx@saint-gobain.com)