

NORTON

SAINT-GOBAIN

clipper

Transforming
surfaces
...and beyond

CS 700

OPERATING INSTRUCTIONS

Translation of the original instructions

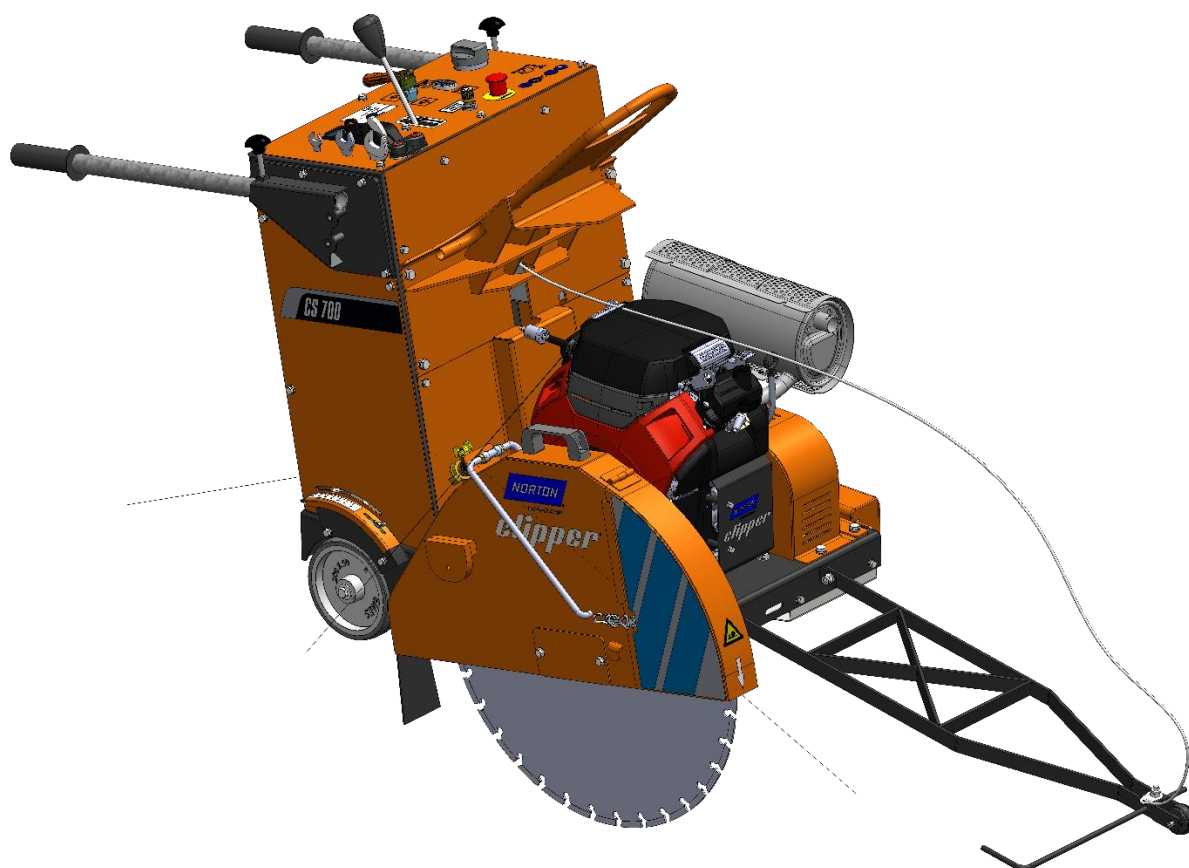

SAINT-GOBAIN



Declaration of conformity

The undersigned manufacturer:

SAINT - GOBAIN ABRASIVES S.A.
190, BD. J. F. KENNEDY
L-4930 BASCHARAGE

Declares that this product:

« Floor saw » : **CS 700**

Code : **70184632548**

is in conformity with the following Directives :

- **"MACHINES" 2006/42/CE**
- **"ELECTROMAGNETIC COMPATIBILITY" 2014/30/UE**
- **"NOISE" 2000/14/CE**

And the European standard:

- **EN 13862 – Floor cutting-off machines – Safety**

Valid for machines as of serial number: 4503330032

Storage site for the technical documents:

Saint-Gobain Abrasives 190, Bd. J. F. Kennedy 4930 BASCHARAGE, LUXEMBOURG

This declaration of conformity loses its validity when the product is converted or modified without agreement.

Bascharage, 221.02.2025.

Fabrice Genuardi, executive officer and responsible for the technical file.
Bascharage, Luxembourg



**UK
CA** **SAINT-GOBAIN**
Declaration of conformity

The undersigned manufacturer:

SAINT - GOBAIN ABRASIVES S.A.
190, BD J.F. KENNEDY
L- 4930 BASCHARAGE

Declares that this product:

« Floor saw »: **CS 700**

Code : **70184632548**

is in conformity with the following standard:

- ***Supply of Machinery (Safety) Regulations 2008***
- ***Electromagnetic Compatibility Regulations 2016***
- ***Noise Emission in the Environment by Equipment for use Outdoors Regulations 2001***

and European standard:

- ***EN 13862 – Floor cutting-off machines – Safety***

Valid for machines with a serial number greater than: 4503330032

Authorised Representative:

SAINT-GOBAIN ABRASIVES

Unicorn House • Unit 1, Amison Close

Redhill Business Park • Stafford • England • ST16 1WB

This declaration of conformity loses its validity when the product is converted or modified without agreement.

Bascharage, 221.02.2025.



Fabrice Genuardi, executive officer and responsible for the technical file.

Bascharage, Luxembourg

CS 700 :

OPERATING INSTRUCTIONS

<u>1</u>	<u>BASIC SAFETY INSTRUCTIONS</u>	<u>6</u>
1.1	<i>Symbols</i>	6
1.2	<i>Machine plate</i>	8
1.3	<i>Safety instructions for particular operating phases</i>	8
<u>2</u>	<u>GENERAL DESCRIPTION OF THE CS 700</u>	<u>9</u>
2.1	<i>Short description</i>	9
2.2	<i>Layout</i>	10
2.3	<i>Technical data</i>	13
2.4	<i>Statement regarding the vibration emission</i>	14
2.5	<i>Statement regarding noise emission</i>	15
<u>3</u>	<u>ASSEMBLY AND COMMISSIONING</u>	<u>16</u>
3.1	<i>Tool assembly (diamond blade)</i>	16
3.2	<i>Side change for cutting</i>	19
3.3	<i>Water Cooling</i>	21
3.4	<i>Starting the machine</i>	22
<u>4</u>	<u>OPERATING THE CS 700</u>	<u>25</u>
4.1	<i>Site of work</i>	25
4.2	<i>Cutting method</i>	25
<u>5</u>	<u>TRANSPORT AND STORING OF CS 700</u>	<u>27</u>
5.1	<i>Securing for transport</i>	27
5.2	<i>Transport procedure</i>	27
5.3	<i>Storage of the machine</i>	27
<u>6</u>	<u>MAINTENANCE</u>	<u>28</u>
6.1	<i>General maintenance of the machine</i>	28
6.2	<i>Engine maintenance</i>	32
<u>7</u>	<u>FAULTS: CAUSES AND CURES</u>	<u>41</u>
7.1	<i>Fault-finding procedures</i>	41
7.2	<i>Trouble-shooting guide</i>	41
7.3	<i>Electrical wiring</i>	42
7.4	<i>Customer service</i>	43
7.5	<i>Spare parts</i>	44

1 BASIC SAFETY INSTRUCTIONS

The CS 700 is exclusively designed for the cutting of floors made of asphalt, green and cured concrete (reinforced or not) as well as of industrial cement.

Uses other than the manufacturer's instructions shall be considered as contravening the regulations. The manufacturer shall not be held responsible for any resulting damage. Any risk shall be borne entirely by the user. Observing the operating instructions and compliance with inspection and servicing requirements shall also be considered as included under use in accordance with the regulations.

1.1 Symbols

Important warnings and pieces of advice are indicated on the machine using symbols. The following symbols are used on the machine:



Read operator's instructions before using the machine



Ear protection must be worn



Hand protection must be worn



Eye protection shall be worn



Depth of Cut Indicator



Danger: risk of cut

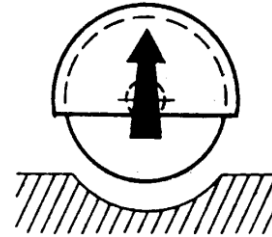
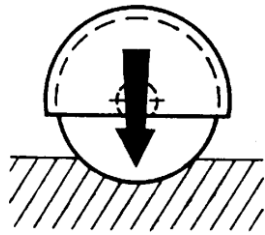

The depth control button allows the blade to be lowered and lifted

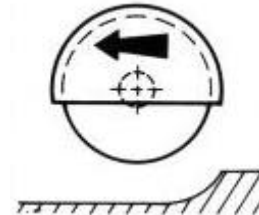
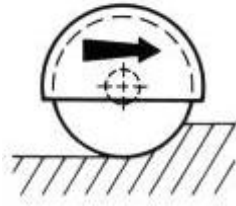

The advance lever of the CS 700 controls the advance and step back of the machine as well as the travel speed

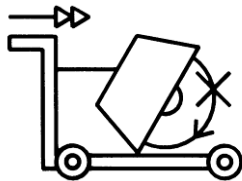

Never move the machine with the blade running idle







Rotation direction of the blade



Emergency Stop

1.2 Machine plate

Important data can be found on the following plate located on the machine:

 190, Bd. J.F. Kennedy L-4930 BASCHARAGE LUXEMBOURG	Code: Machine Code	Year: Year of production	 = Ø Maximum blade mm	UK CA CE EAC
	Mod: Machine Model	W= Weight kg	 = Ø Bore mm	
	EN: Safety standard	P= Power kW	 = Blade speed RPM	
	Type: Machine type	Serial N°: Serial number		

1.3 Safety instructions for particular operating phases

Before commencing work

- Before commencing work, make yourself familiar with the working environment at the place of use. The working environment includes: obstacles in the area of work and manoeuvre, the firmness of the floor, necessary protection at the site relating to public thoroughfares and the availability of help in the event of accidents.
- Check for correct mounting of the blade regularly.
- Immediately remove damaged or badly worn blades, as they endanger the operator whilst rotating.
- Always cut with the blade guard in position.
- Only fit NORTON diamond blades to the machine! The use of other tools can damage the machine!
- Read the disc specifications carefully and verify that it is suitable for your application.
- Please wear safety glasses when cutting, and a dust mask when cutting dry to minimize the effect of dust. Also wear all safety equipment mentioned on the pictograms.
- For security reasons, never leave the machine unattended, untied or unlocked.

While the engine is running

- Do not move the machine whilst the blade is running idle to avoid injury.
- Do not run the machine without the security guards in place.
- Apply cooling water continuously whilst cutting.

Petrol powered machines

- Always use the fuel advised.
- In confined areas, exhaust gases should be evacuated and the job site properly aerated.
- Petrol is flammable. Before filling the tank, shut down the engine, extinguish all open flames and do not smoke. Take care that no diesel is spilled on any motor part. Always wipe up spilled fuel.

2 GENERAL DESCRIPTION OF THE CS 700

Any modification, which could lead to a change in the original characteristics of the machine, may be done only by Saint-Gobain Abrasives S.A. who shall confirm that the machine is still in conformity with the safety regulations. Saint-Gobain Abrasives S.A. keeps the right of making technical or design modification without prior notification.

2.1 *Short description*

The **floor saw CS 700** is used for cutting induction loops, trenches for pipes and cables, and for repairs in asphalt and concrete, in dry cut or water.

The CS 700 is built with high quality materials and robustness guaranteeing a long service life, with minimal maintenance.

The CS 700 is equipped with an automatic advance system as well as an electro-hydraulic blade lifting system. This allows the user to work more easily and comfortably.

The user has systems that make it easy to adjust the cutting depth and maintain the path.

The ergonomic handles are adjustable in height and position. They are also equipped with a system to limit vibrations, thus user fatigue.

The CS 700 can be cut to the right or left of the machine. For this, the blade guard and flanges guard are interchangeable.

Special discs for asphalt, green or old concrete (reinforced or not), as well as cement for industrial floors are available.

2.2 Layout

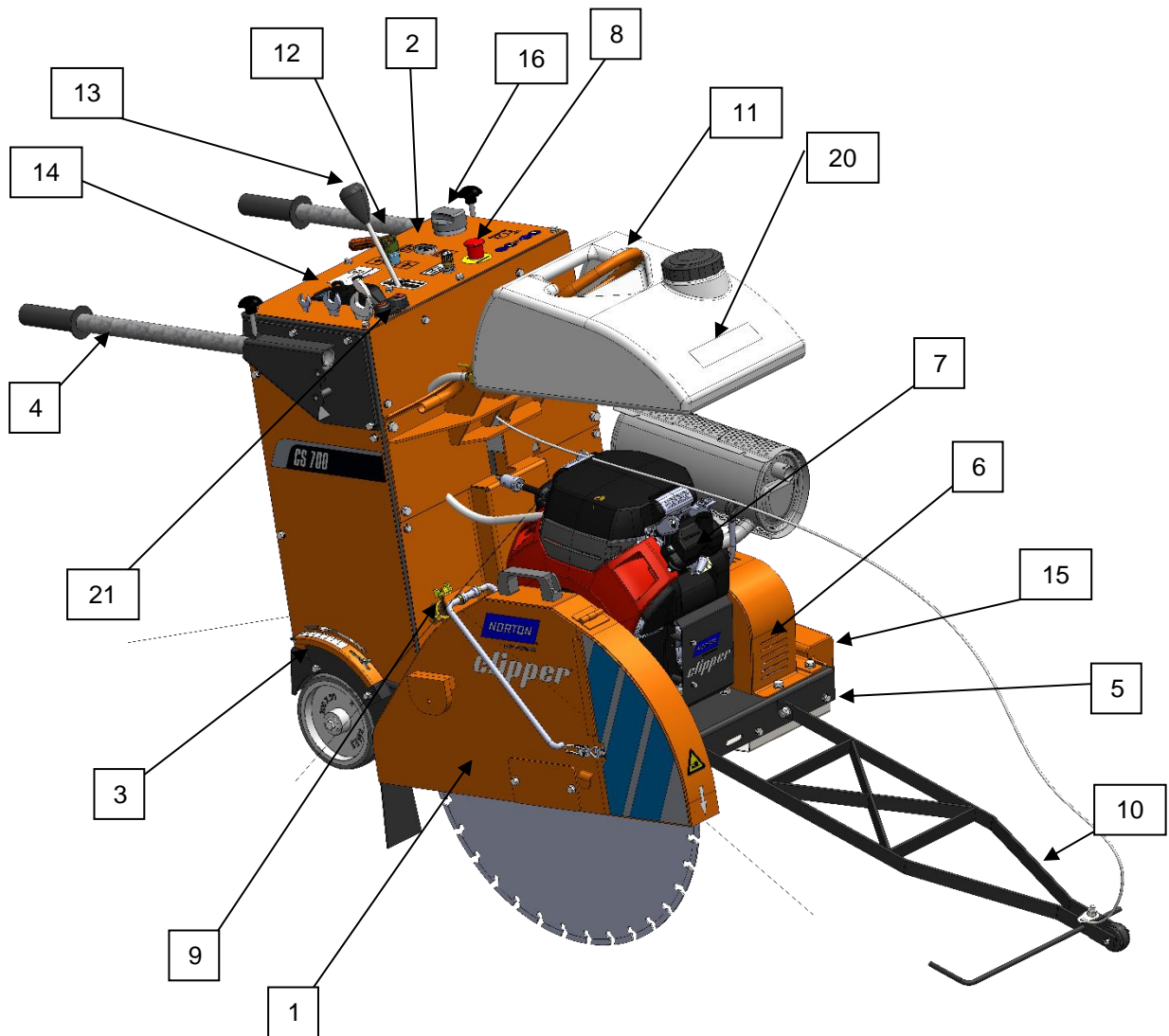

1	Blade guard	12	Clutch handle
2	Depth control button	13	Automatic speed lever
3	Depth gauge	14	Motor control box
4	Handles	15	Wheel shaft housing
5	Swivel frame	16	Gas tank
6	Belt guard	17	Automatic advance module
7	HONDA Engine	18	Electrohydraulic pump
8	Emergency stop	19	Battery
9	Watering system	20	Water tank (optional)
10	Cutting guide	21	Cam latch (for rope)
11	Lifting hook	22	Thermal relay

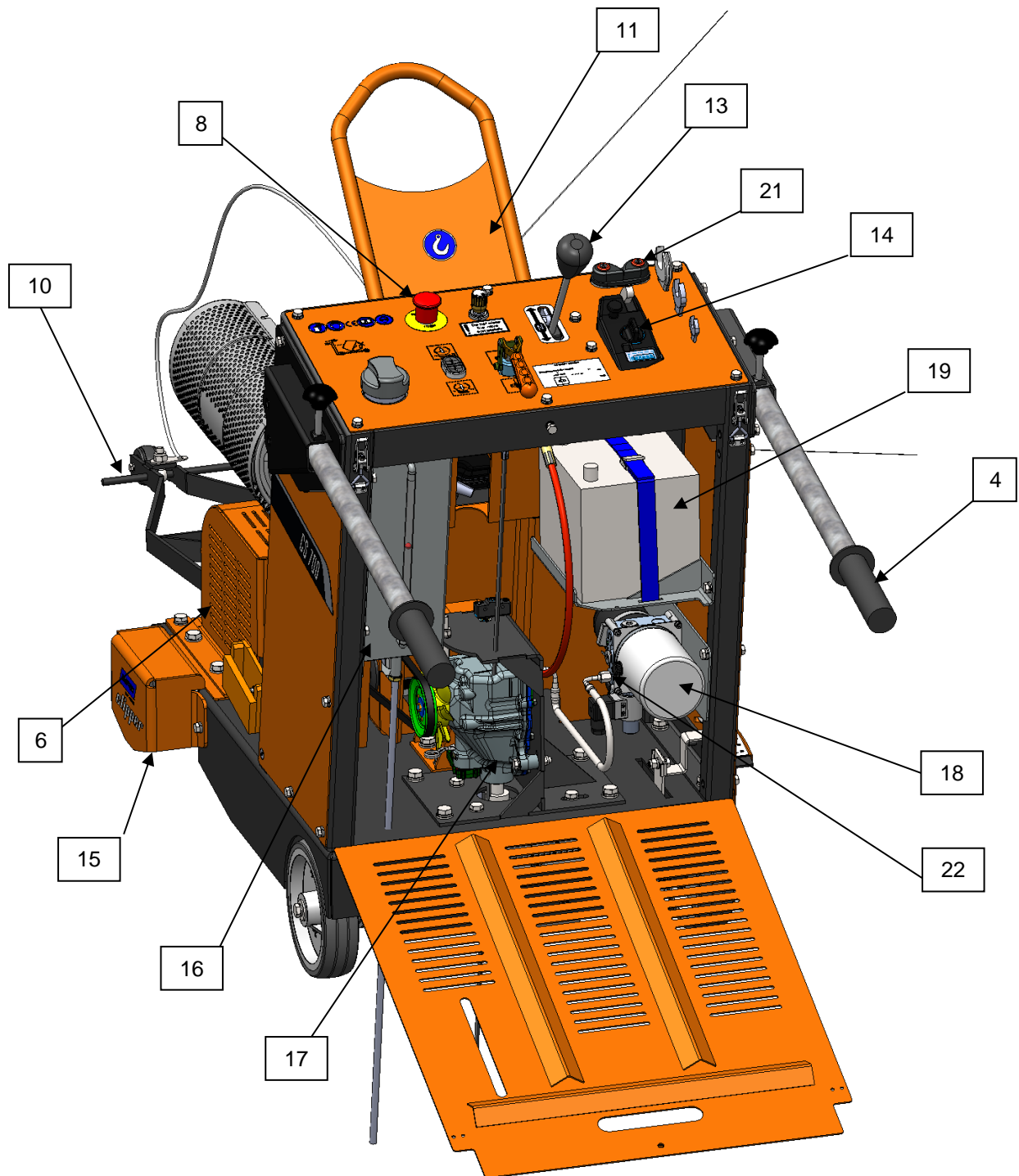

1	Blade guard	12	Clutch handle
2	Depth control button	13	Automatic speed lever
3	Depth gauge	14	Motor control box
4	Handles	15	Wheel shaft housing
5	Swivel frame	16	Gas tank
6	Belt guard	17	Automatic advance module
7	HONDA Engine	18	Electrohydraulic pump
8	Emergency stop	19	Battery
9	Watering system	20	Water tank (optional)
10	Cutting guide	21	Cam latch (for rope)
11	Lifting hook	22	Thermal relay

Made of welded profile steel, the CS 700 is both stable when cutting and easily transportable.

The blade guard (1) provides optimum protection for the operator and the environment. The blade guard is rigidly attached to the main frame. It is removable, making it easier to change the blade. It can be mounted right or left.

A depth control double-buttons (2) allows the adjustment of the blade's cutting depth. A gauge allows you to precisely adjust the depth (3).

The handles (4) are adjustable in position and length. They can also be stored for easy transport and storage of the CS 700. They have a vibration reduction device.

The swivel frame (5) is hinged on the rear axle. It supports the motor, the whole blade shaft, as well as the protective guards. The drive is provided by a set of 5 belts.

The precision-machined blade shaft is mounted in two self-aligning bearings. It is equipped with a groove pulley and is reduced at both ends to a diameter of 25.4mm to allow to attach the inner flange and the blade. The outer flange is held on the shaft by an M12 screw.

The belts guard (6) protects the drive belts and pulleys. The guard is openwork, allowing optimal cooling of the belts.

The Honda GX690 22.1-HP (7) engine is equipped with a punch-type emergency stop (8), mounted on the machine console, which allows the engine to stop in case of danger.

The watering system (9) includes a cat's head to supply the machine with water from the water network and two large nozzles allowing optimal cooling of the blade during cutting. A 25 liter (20) water tank is also available as an option to be independent of the water network.

The cutting guide (10) allows the operator to easily make precise cuts. A cam latch (21) is attached to the console to secure the rope of the cutting guide.

A hook (11) allows the lifting of the CS 700 in an easy and balanced way.

The clutch handle (12) enables the automatic advance of the CS 700. It also serves as a parking brake to secure the CS 700 when not in use.

The advance lever of the CS 700 (13) allows to control the advance and recoil of the machine as well as the speed of movement.

The motor control box (14) allows to start the engine and to adjusts the speed of the motor and therefore the blade.

The blade shaft guard (15) protects the blade shaft during cutting

The fuel tank (16) of about 10l has a filler cap on the control panel and a ventilation located on top of the tank.

A thermal relay (22) is present next to the pump. In case of overload of the electrical circuit, a push button allows to reset the system.

2.3 Technical data

Engine	Honda GX690, 4 strokes, 2 cylinders, 22.1 HP (16,5 kW)
Fuel	Automotive unleaded gasoline RON 91 or more (SP98, SP95, SP95-E5, SP95-E10)
Oil	<p>Use a 4-stroke oil Use 4-stroke engine oil that meets the minimum requirements for the API SJ or later (or equivalent) service category. Always check the API service label on the oil can to make sure it is SJ or later (or equivalent).</p> <p>SAE 10W-30 or 5W-30 oil is recommended for general use. For starting/operating temperatures between -15 and -25°C, use a fully synthetic 5W-30 oil. The other viscosities listed in the table may be used when the average temperature of the place of use is within the range indicated.</p>
Spark plug	ZFR5F (NGK) FRA2 (NGK)
Stater	Electric
Max. blade diameter	700 mm
Bore	25,4 mm
Max. cutting depth mm	275 mm
Flange diameter	125 mm
Blade shaft speed	1850 min ⁻¹
Driving belts	5 (for the blade) 1 (for the automatic advance)
Water tank (optional)	25 l
Machine dimensions (length x width x height)	1270x795x1150 mm en configuration de coupe
Weight	300 kg
Sound pressure level	98.1 dB (A) (according to ISO EN 11201)
Sound power level	118.1 dB (A) (according to ISO EN 3744)
Vibrations hand-arm	6.4 m/s ² (according to EN 12096)

2.4 Statement regarding the vibration emission

Declared vibration emission value in accordance with **EN 12096**

Machine Model / code	Measured vibration emission value a m/s ²	Uncertainty K m/s ²	Tool used Model / code
CS 700 70184632548	6.4	0.5	Pro béton soft Ø700x25.4

- Values determined according to procedure described in annex F of **EN 13862**
- Measurements are made with new machines. Real values in the field could vary the simple one with the double according to operating conditions, depending on:
 - Material
 - Cutting depth
 - Machine wear
 - Lack of maintenance
 - Tool not adapted to application
 - Tool in bad shape
 - Non-specialised operator
 - ...
- Vibrations exposure time depends on cutting performance too (adaptation machine / tool / material / operator)
- When evaluating risks due to hand-arm vibration, you need to take into account effective usage at rated power of machine during a full day of work; quite often you will realise that effective utilisation time represents around 50% of overall duration of work. You have to consider, of course, breaks, water feeding, preparation of work, time to move the machine, disk mounting...

2.5 Statement regarding noise emission

Declared value of noise emission following **EN ISO 11201** and **NF EN ISO 3744**.

Machine Model / code	Sound Pressure level L_{Peq} EN ISO 11201	Uncertainty K (Sound Pressure level L_{Peq} EN ISO 11201)	Sound power level L_{Weq} NF EN ISO 3744	Uncertainty K (Sound power level L_{Weq} NF EN ISO 3744)
CS 700 70184632548	98.1 dB(A)	2.5 dB(A)	118.1 dB(A)	4 dB(A)

- Values determined using the procedure described in the standard EN 13862.
- The measurements are made with new machines. Actual values may vary with site conditions, in terms of:
 - Wear Machine
 - Lack of maintenance
 - Inappropriate tool for application
 - Tool in poor condition
 - Unskilled operator
 - Etc...
- Measured values relate to an operator in normal use, as described in the manual position.

3 ASSEMBLY AND COMMISSIONING

3.1 Tool assembly (diamond blade)

Only use 7NORTON blades of maximum 700mm diameter on CS 700.
Before mounting or changing a blade, switch the machine off.

All tools used must be selected with regard to their maximum permitted cutting speed for the machine's maximum permitted rotation speed.

Warning! Unsuitable cutting speed can damage the machine and/or the blade.

To mount a new blade, follow these steps:

- Lift the disc with the control button.
- Pull the indexer to release the blade guard and remove it with the handle.

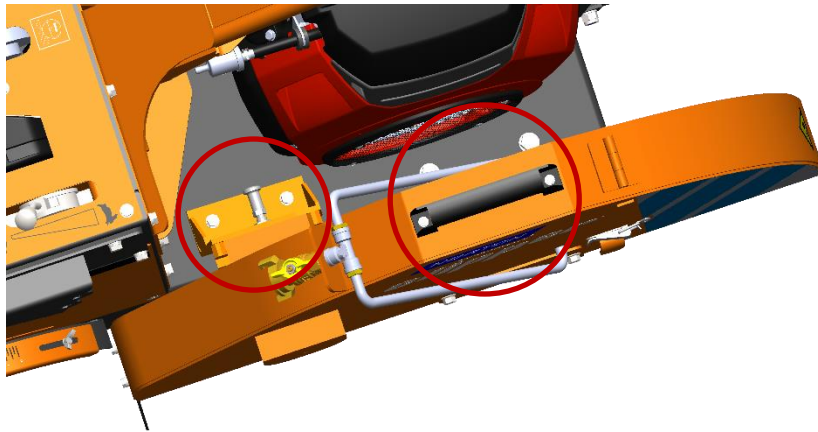

- Loosen the screw holding the movable blade flange (left thread for right cut).
- Remove the screw and mobile flange. A flat spot in the middle of the wheel shaft can help you loosen.

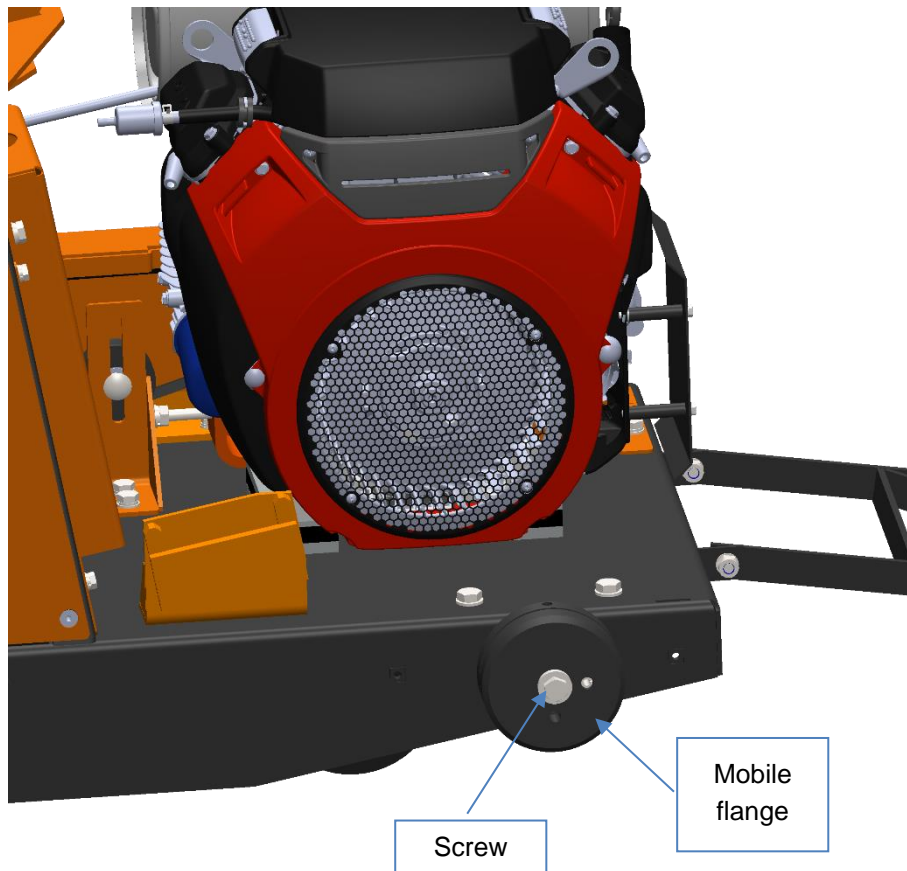

- Check that the flanges and blade at the fixture are clean. Check that the pin is in place.
- Mount the blade on the blade shaft, making sure that the direction of rotation of the disc matches the arrow of the steel center.
- Put the mobile flange back in place.
- Tighten the screw using the wrench supplied (left thread for right cut).

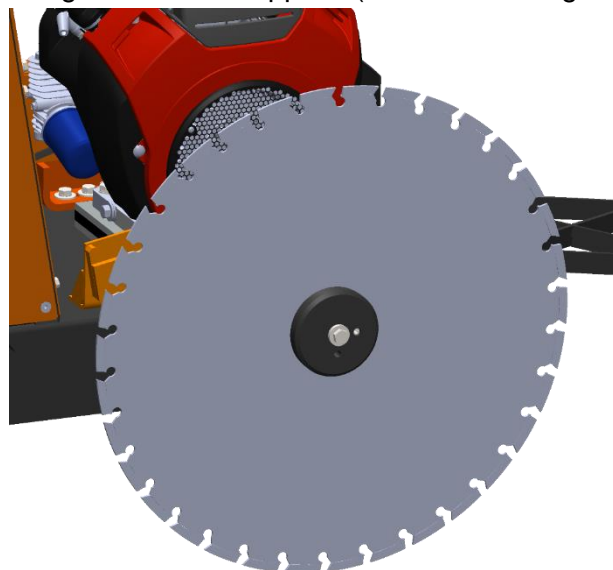

- Replace the blade guard and check that the indexer is in place
- Use the depth control button to lower the blade until it touches the ground slightly. Set the depth gauge to 0 with the adjusting screw. Then go up slightly the blade to move the CS 700 freely

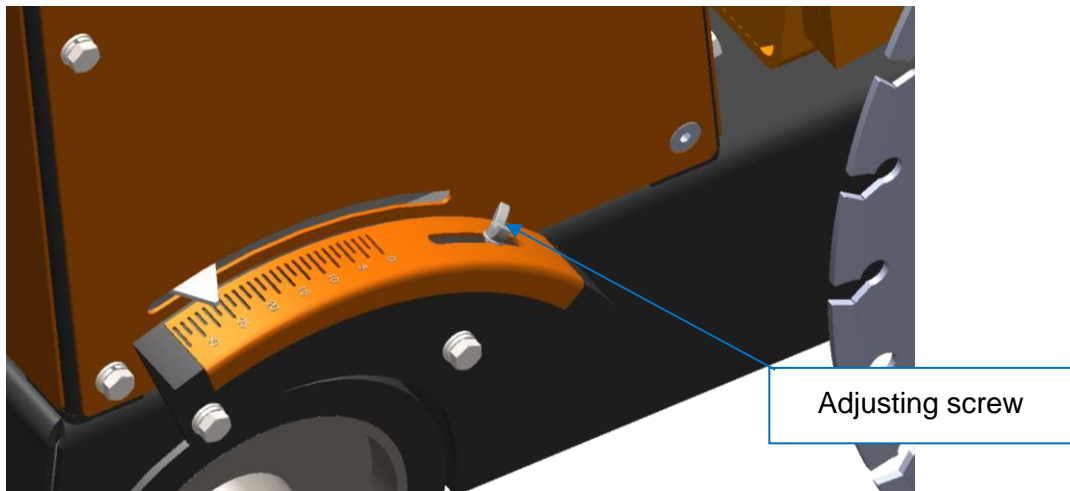

Warning! Check that the bore of the blade corresponds to the diameter of the shaft. Do not mount a blade with a deformed or damaged bore to avoid injury and damage to the machine.

3.2 Side change for cutting

The CS700 allows you to cut to the right or left of the machine. To do this, you must:

- Disassemble the blade guard by pulling the indexer to release the blade guard and remove it with the handle.

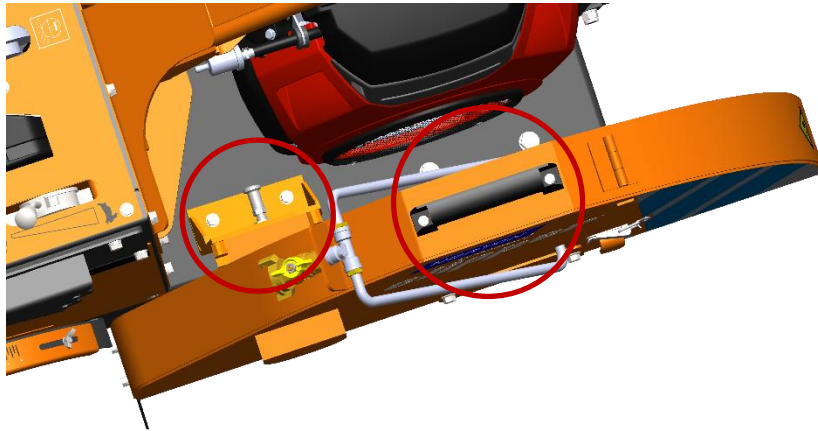

- Change the flange protection plate to the side.

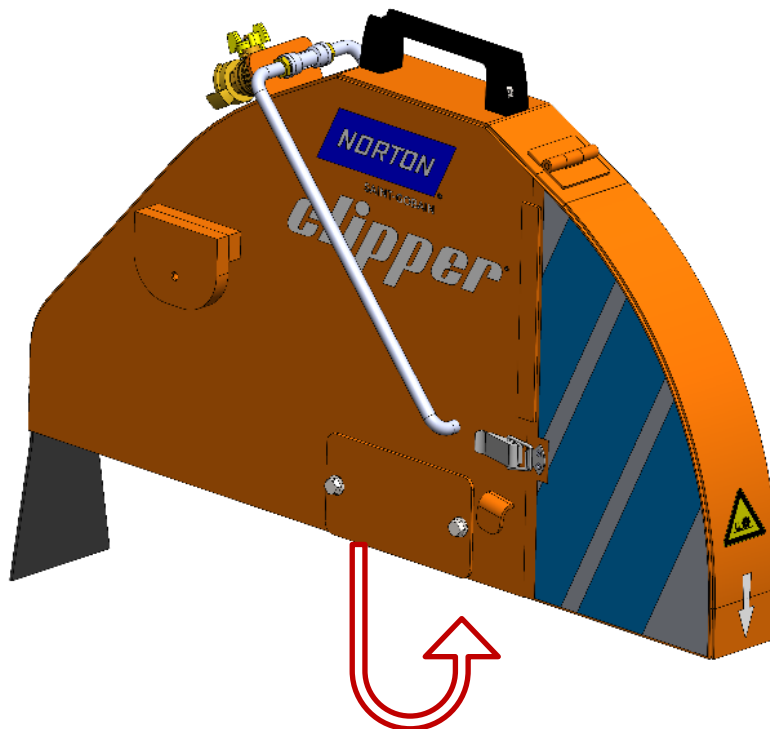

- Disassemble the blade shaft guard by removing the 2 retaining screws

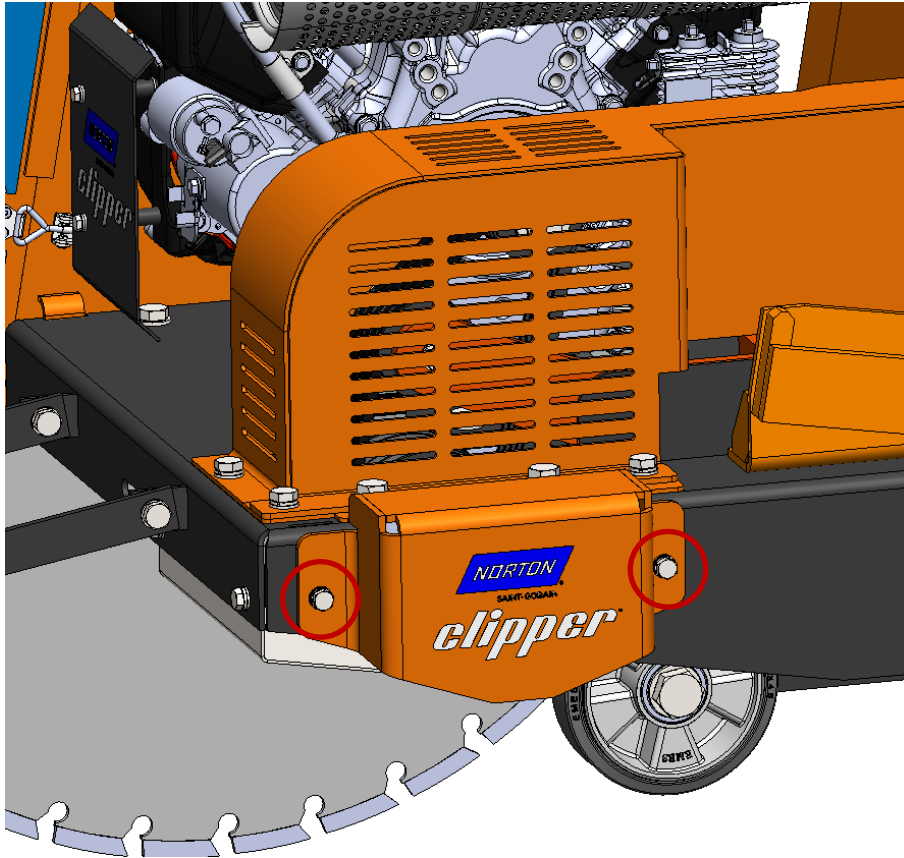

- Put the blade guard on the side where you want to cut and the blade shaft guard on the other side to work safely.

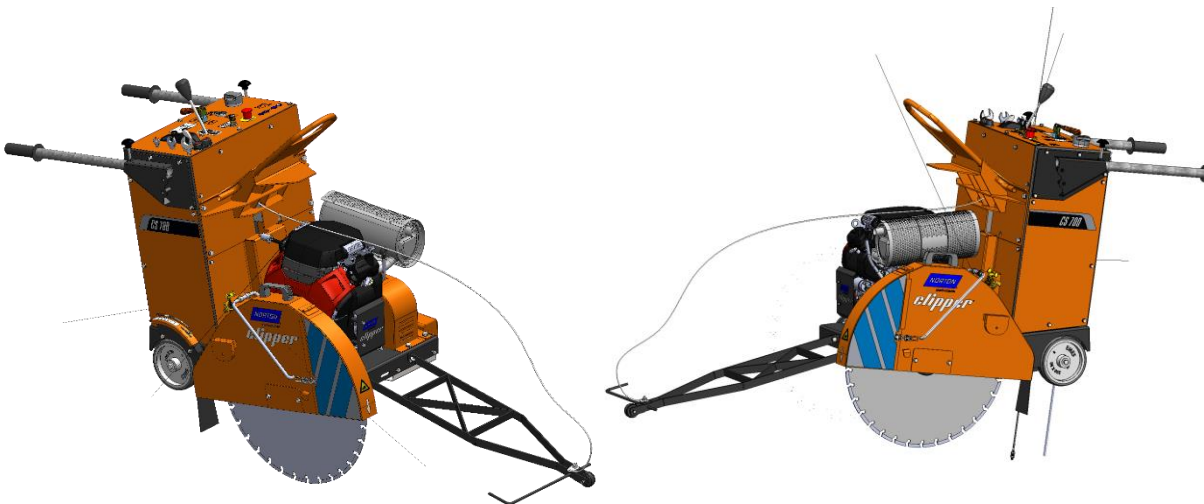

Warning: The CS 700 is not intended to work with one blade on each side simultaneously.

3.3 Water Cooling

Water cooling is possible in 2 ways:

- With a hose connected to the water network
- With water tank (optional)

With the water network:

- Connect the connected hose to the water network directly to the blade guard.
- Adjust the water flow with the tap on the blade guard.

With the water tank (optional):

- Fill the tank with clean water.
- Open the water tap on the tank (the tap should be aligned with the flow direction).
- Make sure the water flows freely through the pipe and covers both sides of the blade properly. If the blade is not sufficiently watered, there is a risk that the segments will heat up, accelerating degradation and increasing the risk of blade failure, and/or excessive dust will result from cutting.
- Flow control can be adjusted with the valve on the blade guard.
- If freezing, remember to empty the water tank.

3.4 Starting the machine

- Make sure that the blade does not touch the floor before starting the machine.
- Check fuel tank valves are open before starting the engine
- Check that the emergency stop is not engaged.
- Check that the clutch handle is in position 0.

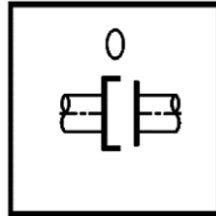

- Start the engine:
 - For a cold motor, pull the starter button to the CLOSE position.
 - For a hot motor, leave the starter button in the OPEN position.

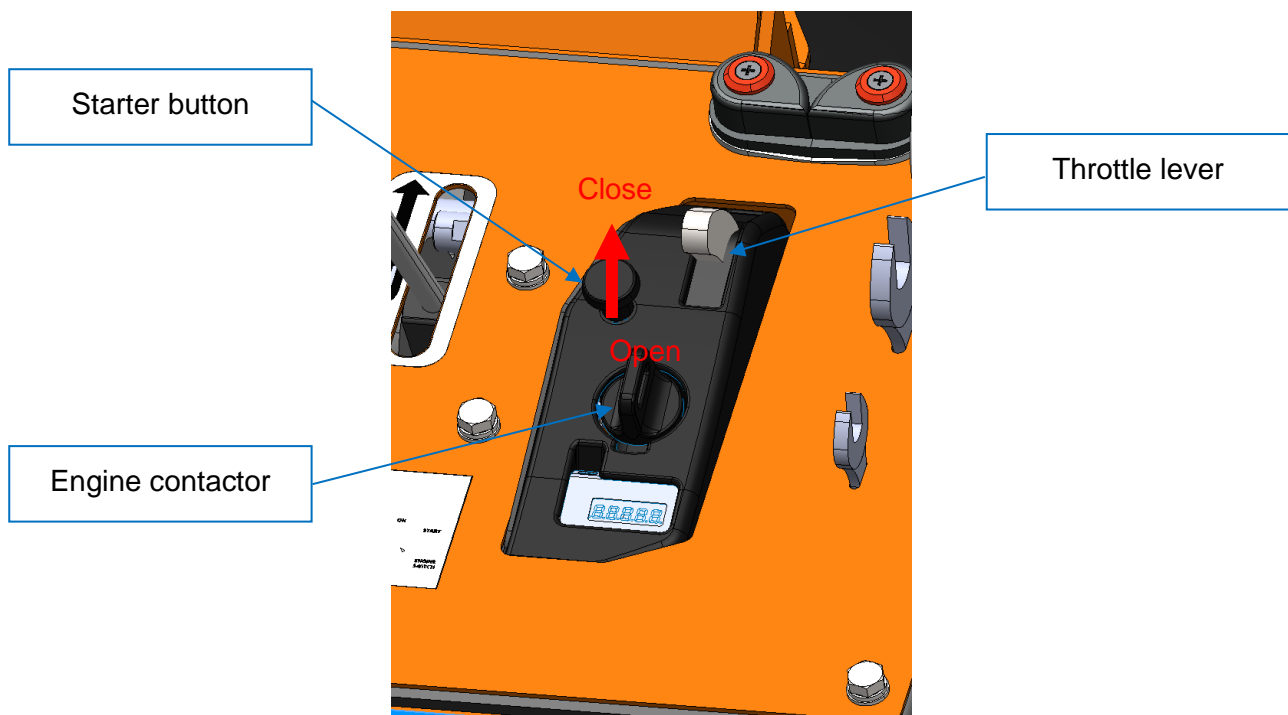

- Move the throttle lever from the MINI. position to approximately 1/3 to the MAXI position.

- Place the motor contactor in the ON position.

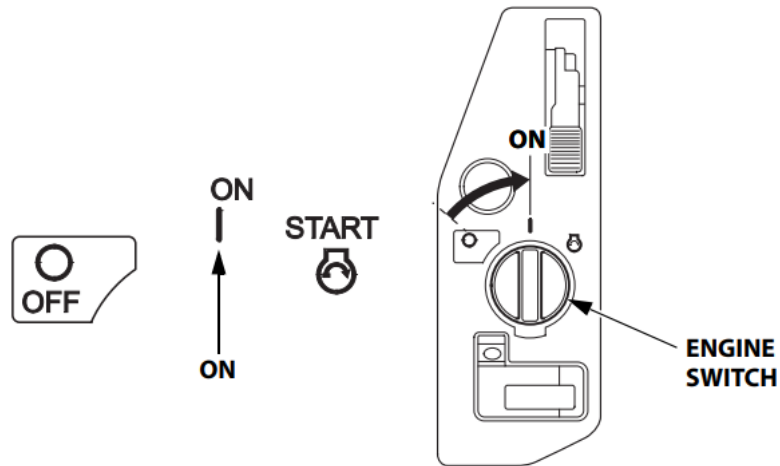

- Turn on the starter.
Place the motor contactor in the START position and hold it in that position until the motor starts.
If the engine does not start within 5 seconds, release the engine contactor and wait at least 10 seconds before restarting the starter.
Do not engage the electric starter for more than 5 seconds in a row as this will cause it to overheat and could damage it. When the engine starts, release the engine contactor and let it return to the ON position.

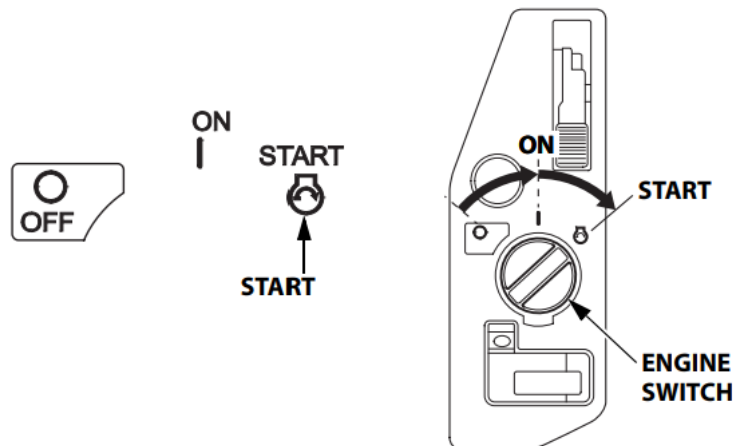

- Allow the engine to heat for 2-3 minutes.

- If you have pulled the starter button OFF to start the engine, gradually push it to the OPEN position as the engine heats up.

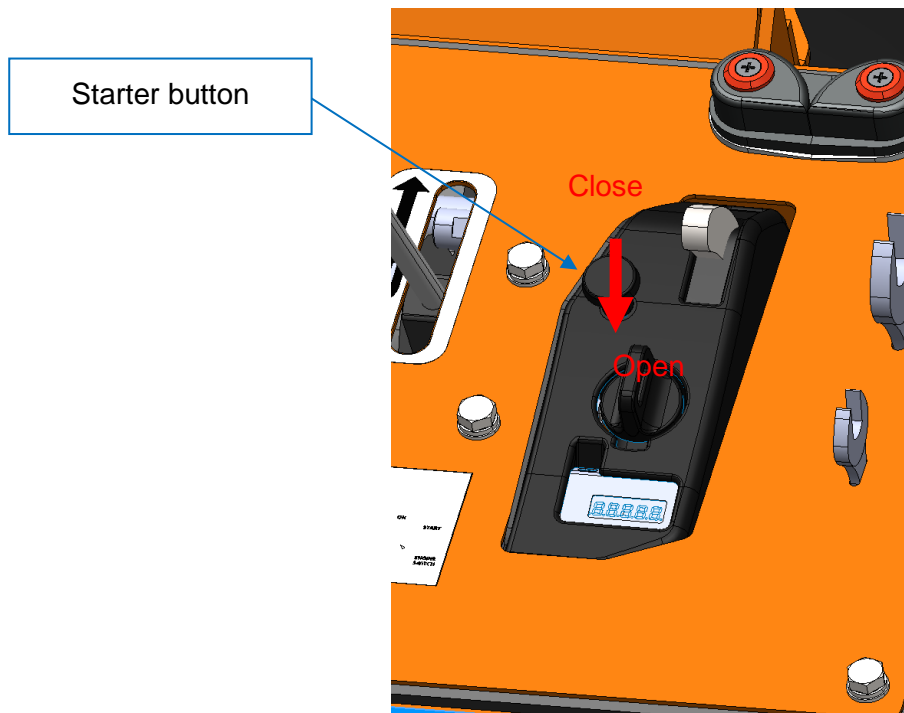

To stop the engine, turn the throttle lever to a minimum and turn the engine switch to the OFF position. Then turn the fuel valve off (closed).

4 OPERATING THE CS 700

4.1 Site of work

Before you start working, please check the following points:

- Remove from the site anything, which might hinder the working procedure.
- Make sure the site is sufficiently well lit.
- If a water hose is used, ensure that it is placed in such a way that it does not damage or interfere with the advance of the machine.
- Make sure you have a continual adequate view of the working area so you can intervene in the working process at any time.
- Keep other staff out of the area, so you can work securely.

4.2 Cutting method

In this section, you can find instructions to make a straight cut at the desired depth.

4.2.1 Preparing your cut

Before starting the machine,

- Draw a line on the ground where the cut should be made along its entire length.
- Check that you have filled the fuel tank and the water tank or, if so, that the water hose is properly connected to the water system. The machine is supplied without fuel.
- Check the oil level. The machine comes with oil.
- Make sure that you have mounted the blade corresponding to your application according to the manufacturer's data so that it corresponds to the material cut, the type of practical cut (water cut or dry cut) and the desired yield.
- Check that the blade is properly held by the flanges.
- Make sure the diamond blade does not touch the ground before starting the engine. Use the depth control button to adjust the height of the blade
- Place the handles at a comfortable height.
- Move the machine until the blade is above one end of the drawn line.
- Lower the cutting guide until it touches the line.
- Align the cutting guide, the viewfinder (thus the blade) on the line.
- Check that the clutch handle is at 0 and the automatic feed lever is in neutral.

4.2.2 Cutting the floor

You can now start the engine. (see part 3.4)

To make your cut,

- Turn on the water tap according to the type of blade used and the cut required:
 - Water cutting: a sufficient amount of water should be used continuously throughout the cutting process to cool the disc properly.
 - Dry cutting: if possible, a small amount of water should be used to limit the creation of dust.

Check the water level regularly if you use the water tank.

- Use the depth control button to lower the blade until it touches the ground slightly.
- Penetrate the disc into the ground to the desired depth using the depth control button. The depth gauge shows you the depth of the disc.
- Once the depth is reached, use the clutch handle to engage the automatic advance

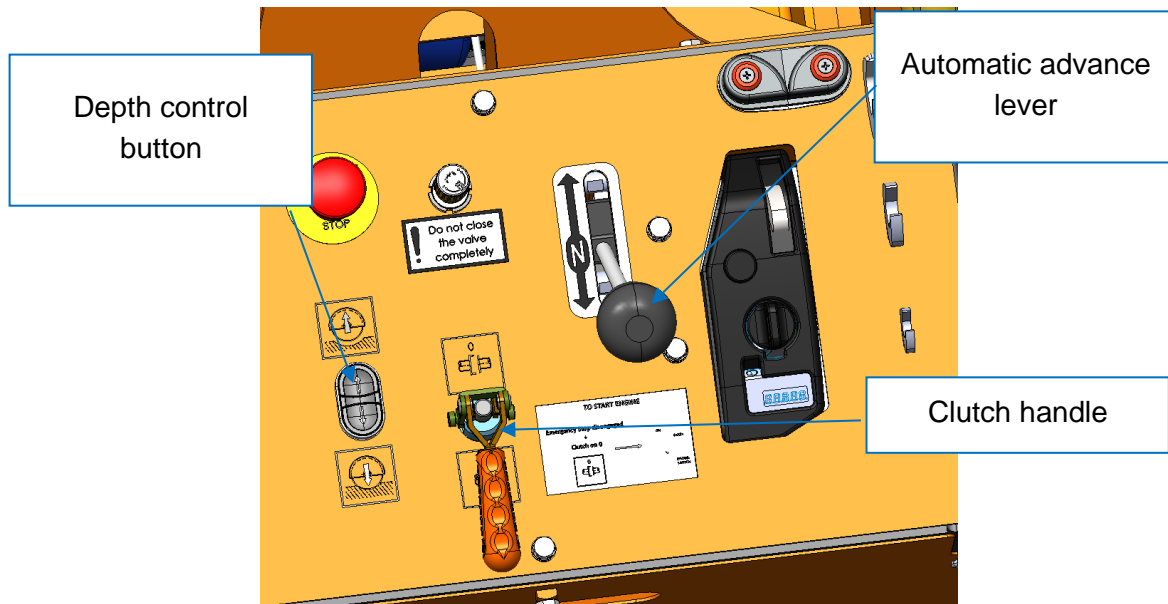

- Use the automatic advance lever to adjust the advance speed. Be careful that the blade does not lift.
- Once cut, bring the automatic advance lever back to stop the machine.
- Use the clutch handle to disengage the automatic advance
- Lift the disc using the depth control button.
- Close the water supply and shut down the engine.

5 TRANSPORT AND STORING OF CS 700

Please follow the following instructions for transporting and storing the machine.

5.1 *Securing for transport*

Before transporting the CS 700:

- Remove the blade
- Empty the water tank
- Raise the cutting guide

5.2 *Transport procedure*

The machine can be moved on flat ground using its wheels. Place the clutch handle in position 1 to use it as a parking brake.

Use only the metal hook above the water tank to hang the machine; the use of any other device (including handles) is absolutely forbidden.

5.3 *Storage of the machine*

If the machine is not going to be used for a long period, please take the following measures:

- Completely clean the machine.
- Relax the drive belts.
- Change the engine oil.
- Unplug the battery.
- Store the machine in a dry, clean, temperature stable place.
- Activate the parking brake by placing the clutch handle on 1.

6 MAINTENANCE

6.1 General maintenance of the machine

Please ensure the maintenance of the machine when it is turned off. During these operations, please wear goggles and a mask. In order to maintain cutting quality over time, and for safe and trouble-free operation of the machine, please follow the following maintenance plan:

		Regular service period Perform at every indicated period						
		After one hour of work	Begin of the day	During the changing of the tool	End of the day	Every week	After a fault	After a damage
Whole machine	Visual control (general aspect, water tightness)							
	Clean							
Flange and blade fixing devices	Clean							
Belts tension	Control							
Water hoses and nozzles	Clean							
Engine housing	Clean							
Reachable nuts and screws	Tighten up							
Automatic advance module	Check the oil level							
Electro-hydraulic pump	Check the oil level							

6.1.1 Adjustment and replacement of the belts

After one hour of work, the belts heat and stretch. Therefore, you have to re-tension them. Check belt tension regularly, especially at the end of each week and after a breakdown or incident. To do this, remove the belt guard by removing the 8 screws.

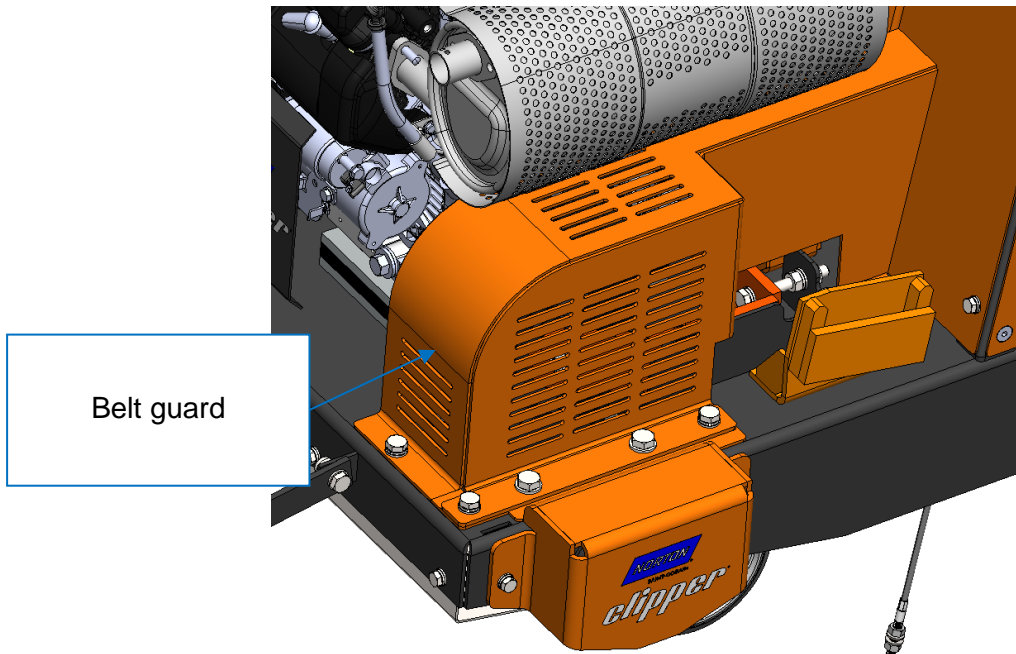

For the belt tensioner roller, loosen the two screws of the tensioner roller support and use the adjustment screw to adjust its position. Once the position has been set to ensure proper belt tension, tighten the belt tensioner roller support screws.

For the automatic advance belt tensioner roller, loosen the tensioner roller screw to move it up and down to adjust the belt tension. Then tighten the screw.

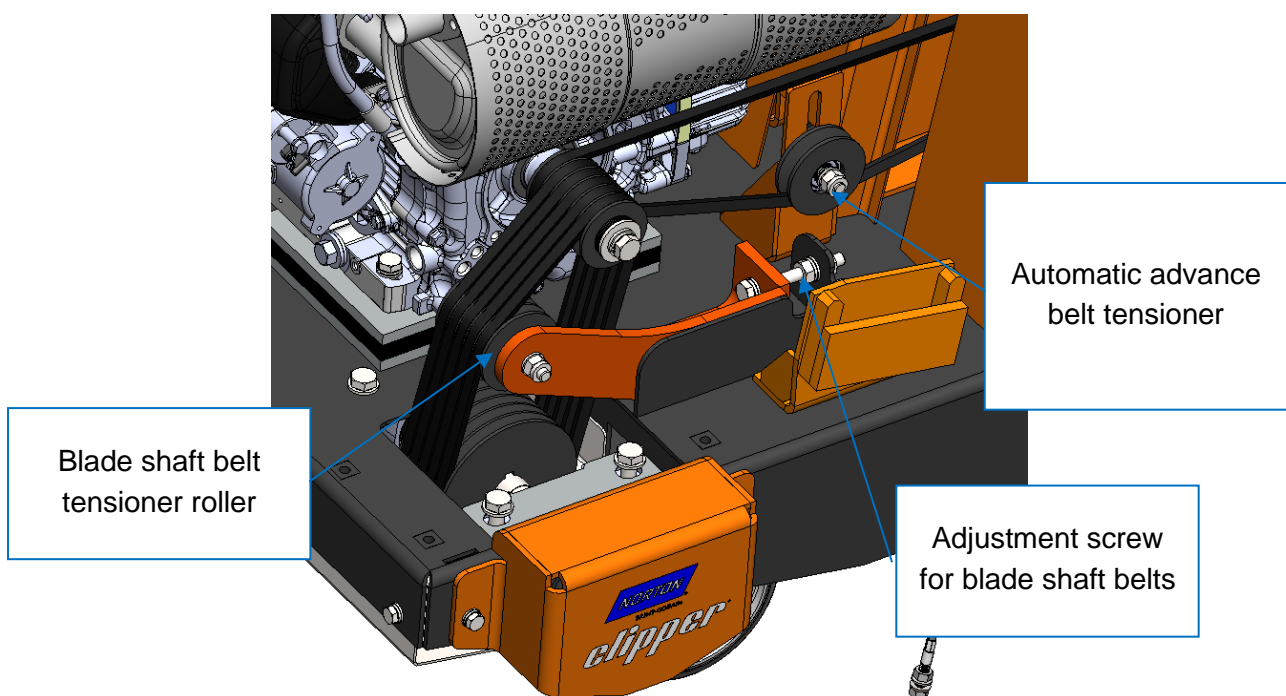

To change the blade shaft belts:

- Loosen the belts by moving the tensioning roller support as far as possible towards the front of the machine.
- Remove the belts.
- Install the new belts.
- Check that the belt pulleys are aligned.
- Replace the tensioner roller support by ensuring proper belt tension.

If replacing the blade shaft belts, always take a set of belts. Never limit yourself to replacing a single belt.

To change the automatic advance belt:

- Remove the blade shaft belts as described above.
- Open the protective panel on the back of the machine by loosening the screw and removing the 2 hooks.

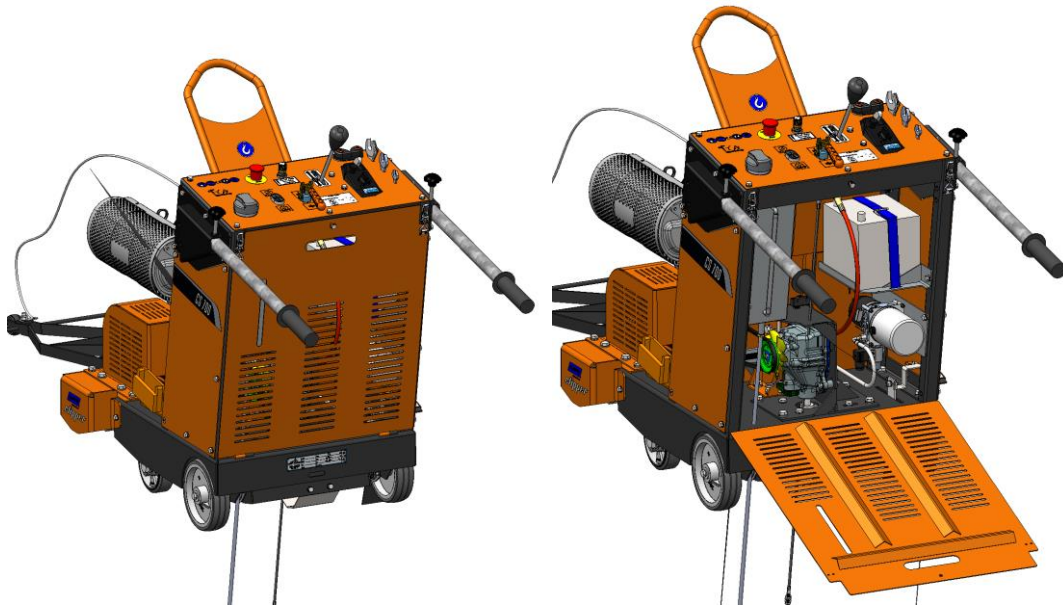

- Loosen the screw behind the automatic advance belt tensioner roller.
- Remove the belt.
- Put the new belt in place.
- Put the tensioner roller back in place and tighten the screw ensuring proper belt tension.
- Mount blade shaft belts using the above instructions.
- Replace the protective panel.

6.1.2 Battery change

Follow this steps to change the battery:

- Open the protective panel on the back of the machine by loosening the screw and removing the 2 hooks. The battery is then accessible.

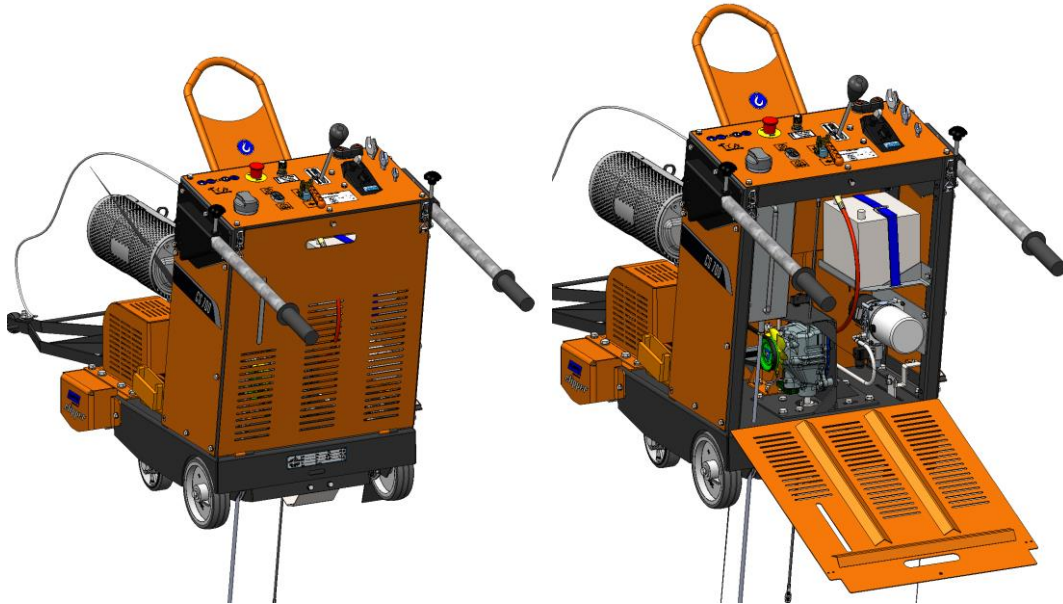

- Disconnect the battery (starting with the black (negative) lug)
- Detach the battery strap support

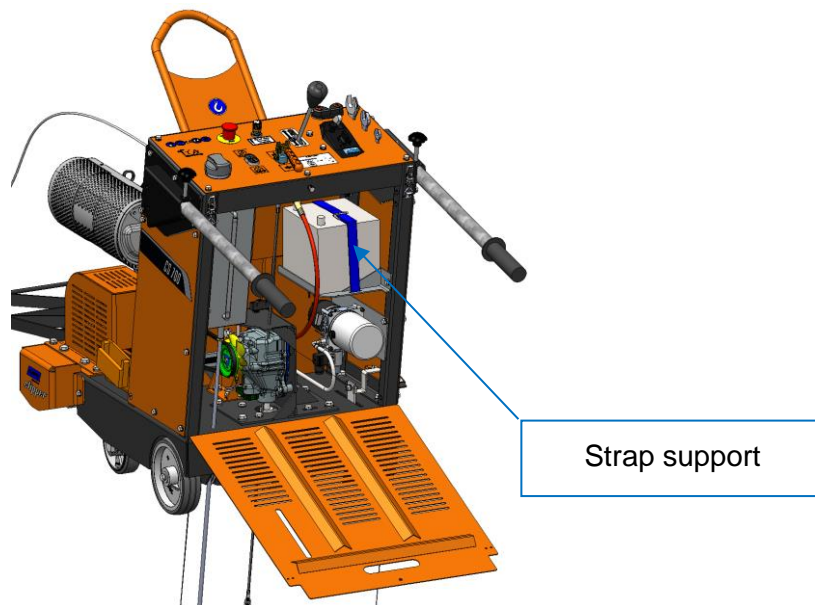

- Change the battery
- Reinstall the strap
- Plug in the battery (starting with the red (positive) lug)
- Replace the protective panel

6.1.3 Clean the machine

The life of your machine depends a lot on its maintenance. Clean it at the end of each day.

6.2 *Engine maintenance*

- Before starting maintenance or repair, make sure the engine is shut down. Disconnect the spark plug cap to avoid accidental start. This will eliminate several potential risks:
 - Carbon monoxide poisoning in engine exhaust gases. Proceed outdoors, away from open windows or doors.
 - Burns from hot parts. Wait for engine and exhaust to cool before touching.
 - Injury from moving parts. Do not run the engine unless indicated in instructions.
- Read the instructions before you start and make sure you have the necessary tools and skills.
- To reduce the risk of fire or explosion, be careful when working around gasoline. To clean parts, only use non-flammable solvents and not gasoline. Do not approach cigarettes, sparks or flames from parts of the fuel system.

Don't forget that the Honda dealership has the best knowledge of the engine and is perfectly equipped for maintenance and repair.

For best quality and reliability, only use new genuine Honda parts or their equivalent for repair and replacement.

6.2.1 Maintenance program

		Regular maintenance period Perform maintenance every month or time interval indicated, whichever comes first. →					
		Each use	First month or 20 h	Every 3 months or 50 h	Every 6 months or 100 h	Once a year or 300 h	Every 2 years or 500 h
Engine oil	Check level						
	Change						
Engine oil filter	Change				Every 200 h		
Air cleaner filter	Check						
	Clean						
	Replace (paper part)						
Spark plug	Check - Adjust						
	Replace						

For the following service, please contact an engine service center.

		Regular maintenance period Perform maintenance every month or time interval indicated, whichever comes first.				
		Each use	First month or 20 h	Every 3 months or 50 h	Every 6 months or 100 h	Once a year or 300 h
Spark arrestor	Clean					
Idle speed	Check - Adjust					
Valve clearance	Check - Adjust					
Combustion chamber	Clean	Toutes les 1000 h				
Fuel filter	Replace					
Fuel pipe	Cheack	Tous les 2 ans (remplacez si nécessaire)				

6.2.2 Engine oil

Oil is a major factor affecting performance and service life. Use 4-stroke automotive detergent oil.

Recommended Oil

Use 4-stroke motor oil that meets or exceeds the requirements for API service category SJ or later (or equivalent). Always check the API service label on the oil container to be sure it includes the letters SJ or later (or equivalent).

SAE 10W-30 or 5W-30 is recommended for general use. Use a full synthetic 5W-30 for starting/operating temperatures between 5°F (-15°C) and -13°F (-25°C). Other viscosities shown in the chart may be used when the average temperature in your area is within the indicated range.

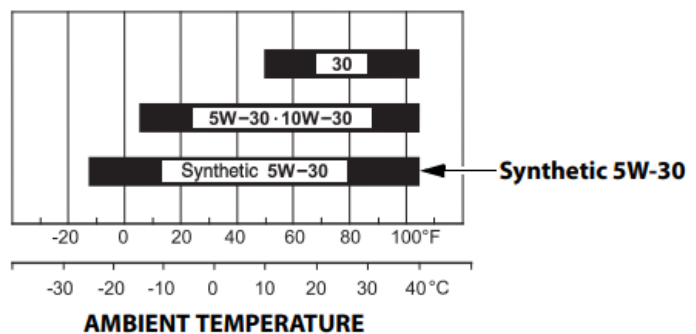

Oil Level Check

Check the engine oil level with the engine stopped and in a level position.

- Start the engine and let it idle for 1 or 2 minutes. Stop the engine and wait for 2 or 3 minutes.
- Remove the oil level dipstick and wipe it clean.
- Fully insert the oil level dipstick, and then remove it to check the oil level.
- If the oil level is low, remove the oil filler cap, and fill with the recommended oil to the upper limit mark on the oil level dipstick.
- Reinstall the oil level dipstick and oil filler cap.

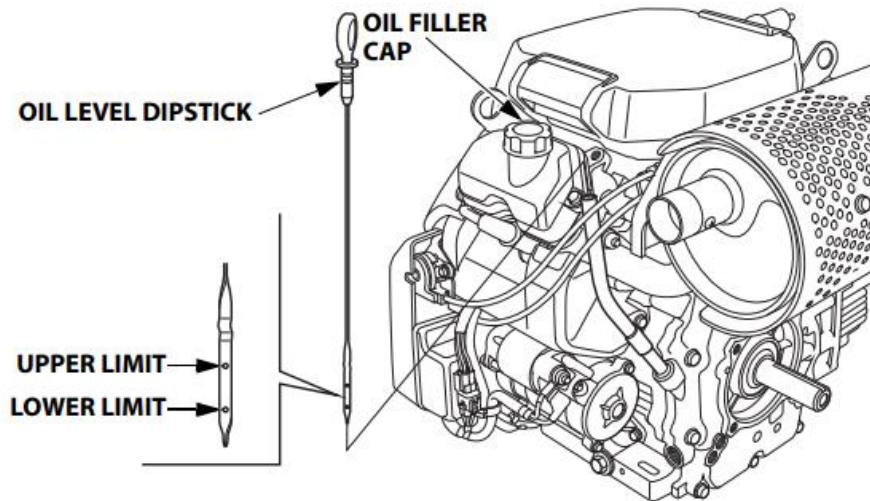

Oil Change

Drain the used oil when the engine is warm. Warm oil drains quickly and completely.

- Place a suitable container below the engine to catch the used oil, and then remove the oil filler cap, drain bolt, and sealing washer.
- Allow the used oil to drain completely, then reinstall the drain bolt and new sealing washer, and tighten the drain bolt securely.

TORQUE: 45.0 N·m (4.5 kgf·m, 33 lbf·ft)

Please dispose of used motor oil in a manner that is compatible with the environment. We suggest you take used oil in a sealed container to your local recycling center or service station for reclamation.

Do not throw it in the trash, pour it on the ground, or pour it down a drain.

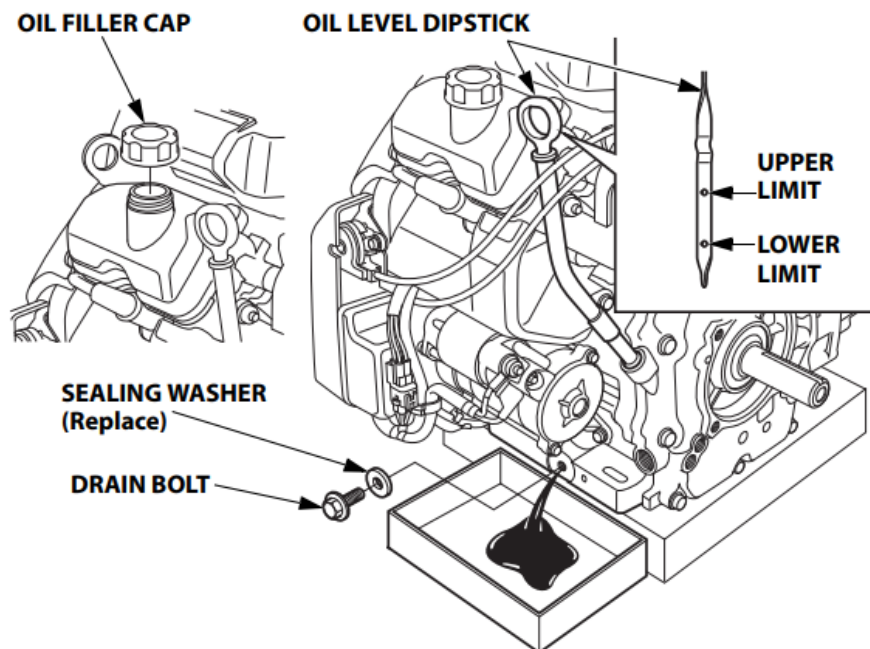

- With the engine in a level position, fill with the recommended oil to the upper limit mark on the oil level dipstick.

Engine oil capacity:

Without oil filter replacement: 1.5 L (1.6 US qt, 1.3 Imp qt)

With oil filter replacement: 1.7 L (1.8 US qt, 1.5 Imp qt)

The Oil Alert system (applicable types) will automatically stop the engine before the oil level falls below the safe limit. However, to avoid the inconvenience of an unexpected shutdown, fill to the upper limit, and check the oil level regularly.

- Reinstall the oil filler cap and oil level dipstick securely.

6.2.3 Oil filter

Change

- Drain the engine oil, and retighten the drain bolt securely.
- Remove the oil filter, and drain the oil into a suitable container. Dispose the used oil and filter in a manner compatible with the environment.
Use an oil filter socket, rather than a strap wrench, to avoid striking and damaging the oil pressure switch.

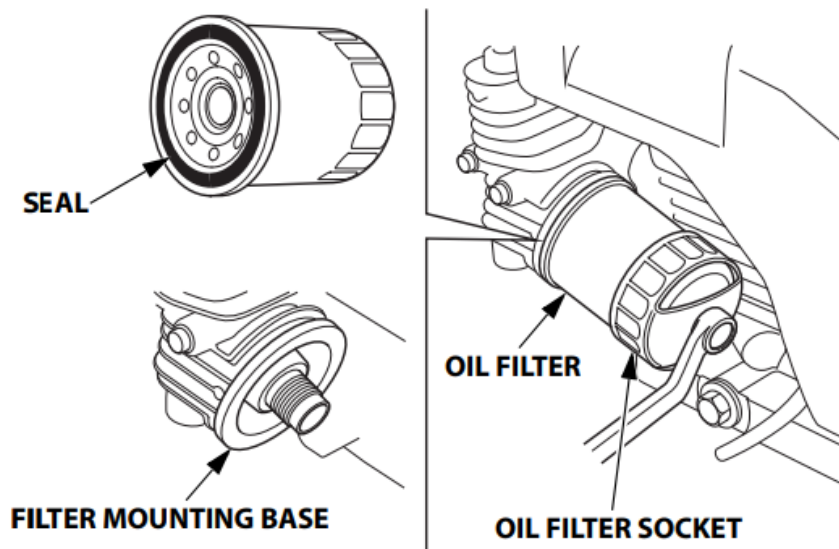

- Clean the filter mounting base, and coat the seal of the new oil filter with clean engine oil. Use only a Honda Genuine oil filter or a filter of equivalent quality specified for your model. Using the wrong filter, or a non-Honda filter which is not of equivalent quality, may cause engine damage.
- Screw on the new oil filter by hand until the seal contacts the filter mounting base, and then use an oil filter socket tool to tighten the filter an additional 3/4 turn.
Oil filter tightening torque: 12 N·m (1.2 kgf·m, 9 lbf·ft)
- Refill the crankcase with the specified amount of the recommended oil (see page 8). Reinstall the oil filler cap and oil level dipstick.
- Start the engine, and check for leaks.
- Stop the engine, and check the oil level as described on page 8. If necessary, add oil to bring the oil level to the upper limit mark on the oil level dipstick.

6.2.4 Air cleaner

A dirty air cleaner will restrict air flow to the carburetor, reducing engine performance. If you operate the engine in very dusty areas, clean the air filter more often than specified in the maintenance schedule.

Operating the engine without an air filter, or with a damaged air filter, will allow dirt to enter the engine, causing rapid engine wear. This type of damage is not covered by the Distributor's Limited Warranty.

Inspection

Remove the air cleaner cover and inspect the filter elements. Clean or replace dirty filter elements. Always replace damaged filter elements.

Cleaning

- Pull the air cleaner cover latch to the unlocked position, and remove the cover.
- Remove the wing nut from the paper filter element.
- Remove the paper filter element and foam filter element from the air cleaner case.
- Remove the foam filter element from the paper filter element.

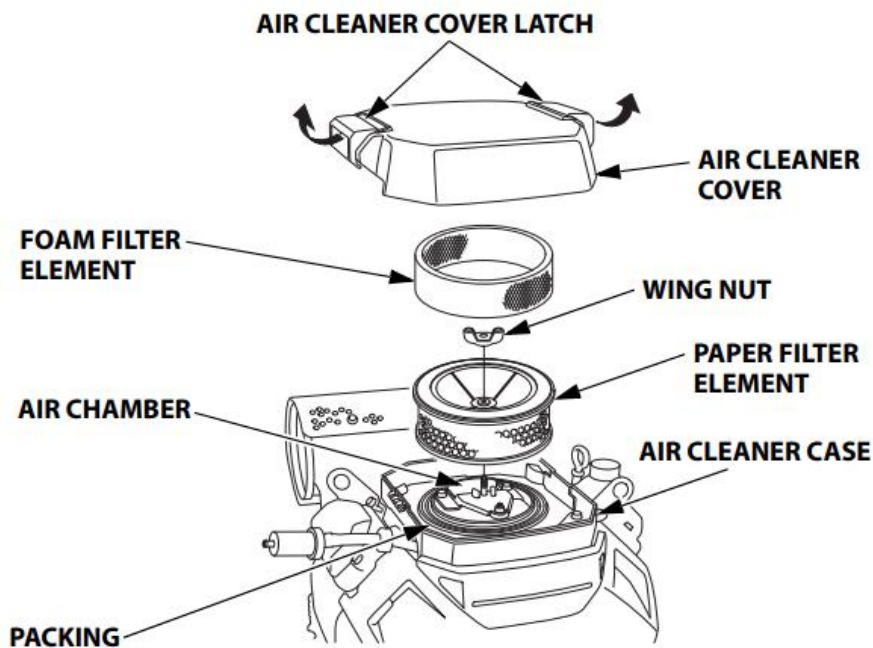

- Inspect both filter elements, and replace them if they are damaged. Always replace the paper filter element at the scheduled interval

- Clean the filter elements if they are to be reused.
Paper filter element: Tap the filter element several times on a hard surface to remove dirt, or blow compressed air [not exceeding 207 kPa (2.1 kgf/cm², 30 psi)] through the filter element from the air cleaner case side. Nettoyez les éléments filtrants s'ils doivent être réutilisés.

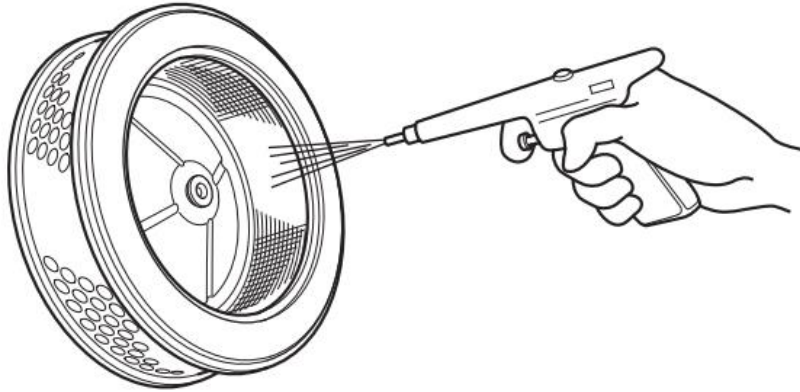

Never try to brush off dirt; brushing will force dirt into the fibers. Replace the paper filter element if it is excessively dirty.

Foam filter element: Clean in warm soapy water, rinse, and allow to dry thoroughly. Or clean in non-flammable solvent and allow to dry. Dip the filter element in clean engine oil, and then squeeze out all excess oil. The engine will smoke when started if too much oil is left in the foam.

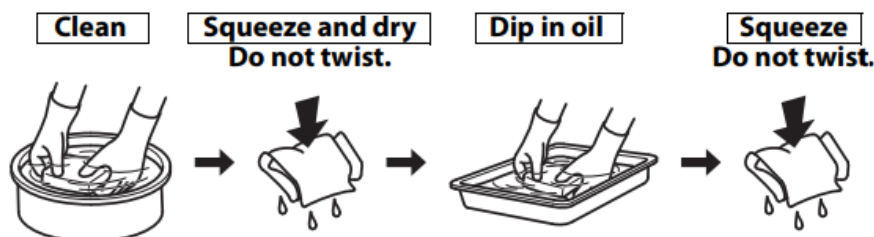

- Wipe dirt from the inside of the air cleaner body and cover, using a moist rag. Be careful to prevent dirt from entering the air chamber that leads to the carburetor.
- Place the foam filter element over the paper filter element and reinstall the assembled filter element. Be sure the packing is in place beneath the filter element. Tighten the wing nut securely.
- Lock the air cleaner cover latch securely.

6.2.5 Spark plug

Recommended Spark Plug: ZFR5F (NGK) ou FR2A (NGK)

The recommended spark plug has the correct heat range for normal engine operating temperatures.

Incorrect spark plugs can cause engine damage.

If the engine has been running, let it cool before servicing the spark plugs.

For good performance, the spark plugs must be properly gapped and free of deposits.

- Disconnect the spark plug caps, and remove any dirt from around the spark plug area.
- Remove the spark plugs with a 5/8-inch spark plug wrench.

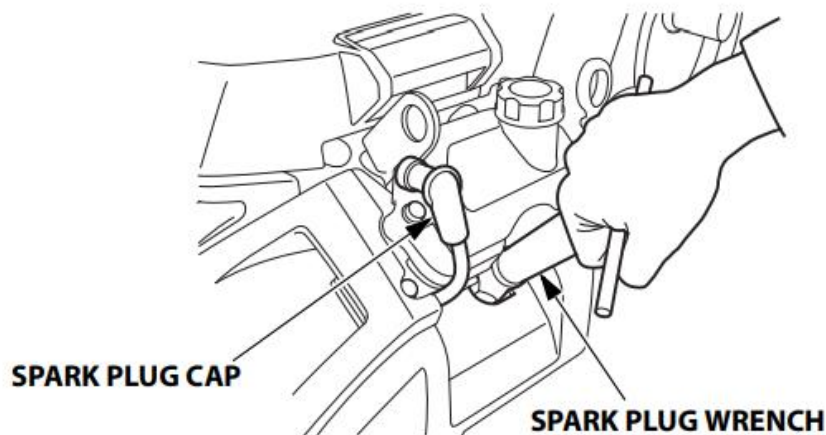

- Inspect the spark plugs. Replace them if damaged, badly fouled, if the sealing washer is in poor condition, or if the electrode is worn.
- Measure the spark plug electrode gaps with a wire-type feeler gauge. Correct the gap, if necessary, by carefully bending the side electrode. The gap should be: 0.7–0.8 mm (0.028–0.031 in)
- Install the spark plug carefully, by hand, to avoid cross-threading.
- After the spark plug is seated, tighten with a 5/8-inch spark plug wrench to compress the sealing washer. When installing a new spark plug, tighten 1/2 turn after the spark plug seats to compress the washer. When reinstalling the original spark plug, tighten 1/8–1/4 turn after the spark plug seats to compress the washer.

TORQUE: 18.0 N·m (1.8 kgf·m, 13 lbf·ft)

A loose spark plug can overheat and damage the engine. Overtightening the spark plug can damage the threads in the cylinder head.

- Attach the spark plug caps to the spark plugs.

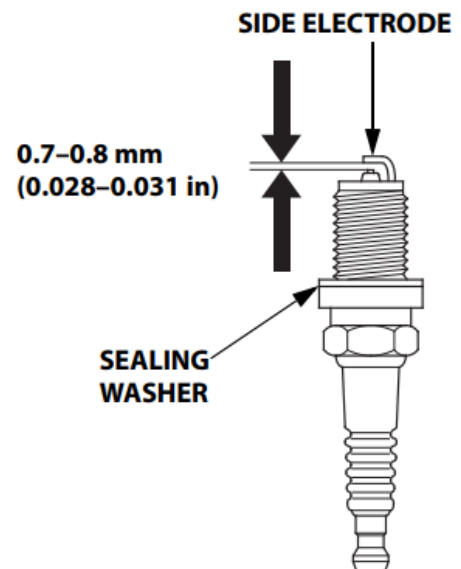

7 FAULTS: CAUSES AND CURES

7.1 *Fault-finding procedures*

Should any fault occur during the use of the machine, turn it off. Let only qualified staff make any intervention other than the one described in the previous section.

7.2 *Trouble-shooting guide*

Trouble	Possible source	Resolution
Hard starting	Not enough fuel	Fill fuel tank
	Fuel filter clogged	Clean fuel filter
	Spark plug faulty	Inspect spark plug
	Low or defective battery	Load or change the battery
	Thermal relay trigger	Reset the system (button next to the pump)
	Stronger fault	Contact nearest engine maintenance centre
The blade doesn't rotating	Belt not tensioned or defective	Check belt tension and change if necessary.
Engine lacks power	Air filter restricted	Clean or replace air filter
	Stronger fault	Contact nearest engine maintenance centre
No water on the blade	Not enough water in tank	Fill water tank
	Water tap on blade guard is closed	Open the tap
	Plugged water supply system	Clean the water supply system

7.3 Electrical wiring

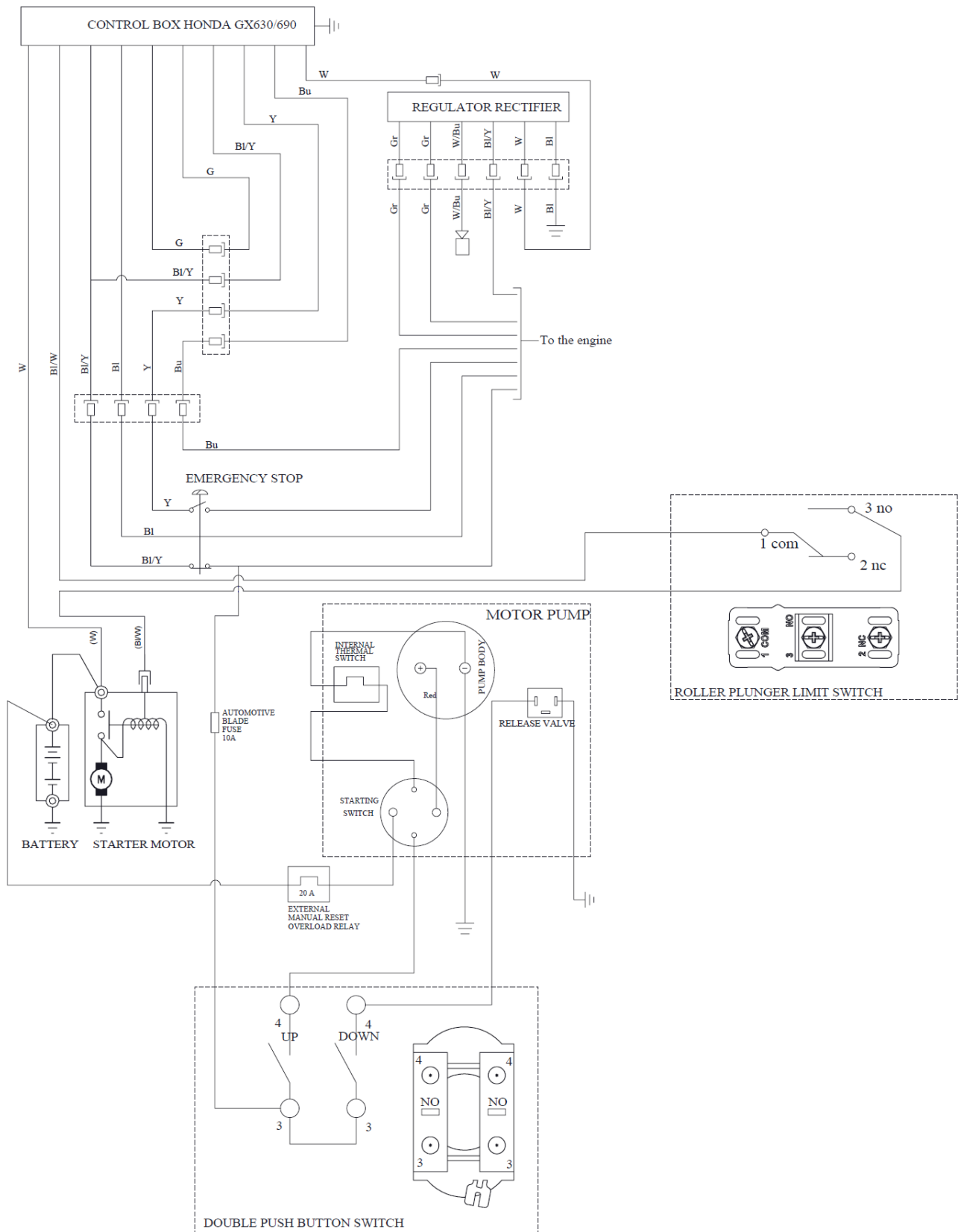

7.4 Customer service

When ordering spare parts, please mention:

- The serial number (7 digits).
- The code of the part.
- The exact denomination.
- The number of parts required.
- The delivery address.
- Please indicate clearly the means of transportation required such as "express" or "by air". Without specific instructions, we will forward the parts through the means which seem appropriate to us --- but which is not always the quickest way.

Clear instructions will avoid problems and faulty deliveries.

If not sure, please send us the defective part.

In the case of a warranty claim, the part must always be returned for evaluation.

Spare parts for the motor can be ordered with the manufacturer of the motor or with their dealer, which is often quicker and cheaper.

This machine has been manufactured by: Saint-Gobain Abrasives S.A.

190, Bd. J. F. Kennedy

L- 4930 BASCHARAGE

Grand-duché de Luxembourg.

Tel.: 00352-50 401-1

Fax: 00352- 50 16 33

<http://www.construction.norton.eu>

e-mail: sales.nlx@saint-gobain.com

7.5 Spare parts

In order to consult the spare parts lists, we invite you to visit the after-sales website of Norton Clipper by using the following address:

<https://spareparts.nortonabrasives.com>

For a quick access, you can also use the QR Code shown below using your mobile phone:



This electronic catalogue provides exploded views and spare parts lists for different machines designed by Norton Clipper so you can find references you need.

Guarantee can be claimed and technical support obtained from your local distributor where machines, spare parts and consumables can be ordered as well:

SAINT-GOBAIN ABRASIVES
INDUSTRIEWEG 21
9420 ERPE-MERE
BELGIUM
TEL: +32(0) 2 267 21 00

SAINT-GOBAIN CONSTRUCTION
PRODUCTS CZ A.S
DIVIZE ABRASIVES
SMRČKOVA 2485/4
180 00 PRAHA 8
TEL: +420 255 719 326
FAX: +420 255 719 321

SAINT-GOBAIN ABRASIVES A/S
DYBENDALSVEJENGET 2,
DK-2630 TAASTRUP
DENMARK
TEL: +45 4675 5244

PO BOX 643706
FORTUNE TOWER OFFICE 2106
JLT BLOCK C
(NEXT TO METRO STATION)
JUMEIRA LAKE TOWER, DUBAI
UNITED ARAB EMIRATES
TEL: +971 4 431 5154
FAX: +971 4 431 5434

SAINT-GOBAIN ABRASIFS
RUE DE L'AMBASSADEUR - B.P.8
78 702 CONFLANS CEDEX
FRANCE
TEL: +33 (0)1 34 90 40 00
FAX: +33 (0)1 39 19 89 56

SAINT-GOBAIN ABRASIVES GMBH
BIRKENSTRASSE 45-49
D-50389 WESSELING
GERMANY
TEL: +49 (0) 2236 703-0
FAX: +49 (0) 2236 703-730

SAINT-GOBAIN ABRASIVES KFT.
1225 BUDAPEST
BÁNYALÉG U. 60/B.
HUNGARY
TEL: +36 1 371 22 50
FAX: +36 1 371 22 55

SAINT-GOBAIN ABRASIVI S.P.A
VIA PER CESANO BOSCONI 4
I-20094 CORSICO MILANO
ITALY
TEL: +39 02 44 851
FAX: +39 02 44 78 266

SAINT-GOBAIN ABRASIVES S.A.
190 RUE J.F. KENNEDY
L-4930 BASCHARAGE
GRAND DUCHE DE LUXEMBOURG
TEL: +352 50 401 1
FAX: +331 83 717 792
NO. VERT (FRANCE): 0800 906 903

SAINT-GOBAIN ABRASIFS, S.A.
2 ALLÉE DES FIGUIERS
AIN SEBAË - CASABLANCA
MOROCCO
TEL: +212 5 22 66 57 31
FAX: +212 5 22 35 09 65

SAINT-GOBAIN ABRASIVES BV
GROENLOSEWEG 28
7151 HW EIBERGEN
P.O. BOX 10
7150 AA EIBERGEN
THE NETHERLANDS
TEL: +31 545 466466
FAX: +31 545 474605

SAINT-GOBAIN ABRASIVES AS
KARIHAUGVEIEN, 89
0186 OSLO
NORWAY
TEL: +47 63 87 06 00
FAX: +47 63 87 06 01

SAINT-GOBAIN HPM POLSKA SP. Z O.O.
UL. NORTON 1, 62-600 KOŁO
62-600 KOŁO
POLAND
TEL: +48 63 26 17 100
FAX: +48 63 27 20 401

SAINT-GOBAIN ABRASIVOS, L. DA
ZONA INDUSTRIAL DA MAIA
I-SECTOR VIII, NO. 122
APARTADO 6050
4476 - 908 MAIA
PORTUGAL
TEL: +351 229 437 940
FAX: +351 229 437 949

SAINT-GOBAIN GLASS
BUSINESS UNIT ABRASIVI
PUNCT DE LUCRU : LOC.VETIS, JUD.
SATU MARE 447355
STR. CAREIULUI 11
PARC INDUSTRIAL RENOVATIO
ROMANIA
TEL: +40 261 839 709
FAX: +40 261 839 710

SG HPM RUS
58, F. ENGELS STR.
STROENIE 2
105082 MOSCOW
RUSSIA
TEL: +74 955 408 355
FAX: +74 959 373 224

SAINT-GOBAIN
ABRASIVES (PTY) LTD
2 MONTEER ROAD
ISANDO 1600
P.O. BOX 67
SOUTH AFRICA
TEL: +27 11 961 2000
FAX: +27 11 961 2184/5

SAINT-GOBAIN ABRASIVOS, S.A.
CTRA. DE GUIPÚZCOA, KM. 7,5
E-31195 BERRIOPLANO (NAVARRA)
SPAIN
TEL: +34 948 306 000
FAX: +34 948 306 042

SAINT GOBAIN ABRASIVES AB
GÅRDSFOGDEVÄGEN 18A
168 66 BROMMA • SVERIGE
SWEDEN
TEL: +46 8 580 881 00
FAX: +46 8 580 881 30

SAINT-GOBAIN INOVATIF MALZEMELER
VE ASINDIRICI SAN. TIC. AS.
ALTAYÇEŞME MAH. ÇAMLI SOK. NO:21
ESAS OFIS PARK KAT:9 34843
MALTEPE, İSTANBUL • TURKEY
TEL: 0090-216-217 12 50
FAX: 0090-216-442 40 74

SAINT-GOBAIN ABRASIVES LTD.
UNICORN HOUSE UNIT 1, AMISON CLOSE
REDHILL BUSINESS PARK
STAFFORD ST161WB
UNITED KINGDOM
TEL: +44 1785 279 553
FAX: +44 1785 213 487



Saint-Gobain Abrasifs
190 Rue J.F. Kennedy
L-4930 Bascharage
Grand Duche de Luxembourg
Tel: +352 50 4011
Fax: +331 83 717 792
no. vert (France) 0800 906 903

www.nortonabrasives.com/fr-fr