

# CS 352

## OPERATING INSTRUCTIONS

Translation of the original instructions



SAINT-GOBAIN







The undersigned manufacturer:

**SAINT - GOBAIN ABRASIVES S.A.  
190, BD. J. F. KENNEDY  
L-4930 BASCHARAGE**

Declares that this product:

« Floor saw »: **CS 352 P6.5**

Code : **70184632007**

is in conformity with the following Standards:

- **"MACHINES" 2006/42/CE**
- **"NOISE" 2000/14/CE**

And the European standard:

- **EN 13862 – Floor cutting-off machines – Safety**

Valid for machines as of serial number: 4503163707

Storage site for the technical documents:

Saint-Gobain Abrasives 190, Bd. J. F. Kennedy 4930 BASCHARAGE, LUXEMBOURG

This declaration of conformity loses its validity when the product is converted or modified without agreement.

Bascharage, 16/03/2023

A handwritten signature in blue ink, appearing to read "F. Chianese".

François Chianese, executive officer and responsible for the technical file.  
Bascharage, Luxembourg.



The undersigned manufacturer:

**SAINT - GOBAIN ABRASIVES S.A.**  
**190, BD J.F. KENNEDY**  
**L- 4930 BASCHARAGE**

Declares that this product:

« Floor saw »: **CS 352 P6.5**

Code : **70184632007**

is in conformity with the following standard:

- ***Supply of Machinery (Safety) Regulations 2008***
- ***Noise Emission in the Environment by Equipment for use Outdoors Regulations 2001***

and European standard:

- ***EN 13862 – Floor cutting-off machines – Safety***

Valid for machines with a serial number greater than: 4503163707

Authorised Representative:

SAINT-GOBAIN ABRASIVES

Unicorn House • Unit 1, Amison Close

Redhill Business Park • Stafford • England • ST16 1WB

This declaration of conformity loses its validity when the product is converted or modified without agreement.

Bascharage, 16/03/2023

François Chianese, executive officer and responsible for the technical file.  
Bascharage, Luxembourg.

# CS 352

## OPERATING INSTRUCTIONS

<b><u>1</u></b>	<b><u>BASIC SAFETY INSTRUCTIONS</u></b>	<b>6</b>
1.1	<i>Symbols</i>	6
1.2	<i>Machine plate</i>	7
1.3	<i>Safety instructions for particular operating phases</i>	8
<b><u>2</u></b>	<b><u>GENERAL DESCRIPTION OF THE CS 352</u></b>	<b>9</b>
2.1	<i>Short description</i>	9
2.2	<i>Layout</i>	10
2.3	<i>Technical data</i>	12
2.4	<i>Statement regarding the vibration emission</i>	13
2.5	<i>Statement regarding noise emission</i>	14
<b><u>3</u></b>	<b><u>ASSEMBLY AND COMMISSIONING</u></b>	<b>15</b>
3.1	<i>Assembly</i>	15
3.2	<i>Tool assembly</i>	15
3.3	<i>Water cooling system</i>	15
3.4	<i>Starting the machine</i>	16
<b><u>4</u></b>	<b><u>OPERATING THE CS 352</u></b>	<b>17</b>
4.1	<i>Site of work</i>	17
4.2	<i>Cutting method</i>	17
<b><u>5</u></b>	<b><u>TRANSPORT AND STORING</u></b>	<b>18</b>
5.1	<i>Securing for transport</i>	18
5.2	<i>Transport procedure</i>	18
5.3	<i>Long period of inactivity</i>	18
<b><u>6</u></b>	<b><u>MAINTENANCE AND SERVICE</u></b>	<b>19</b>
6.1	<i>Maintenance of the machine</i>	19
6.2	<i>Maintenance of the engine</i>	20
<b><u>7</u></b>	<b><u>FAULTS: CAUSES AND CURES</u></b>	<b>23</b>
7.1	<i>Fault-finding procedures</i>	23
7.2	<i>Trouble-shooting guide</i>	23
7.3	<i>Customer service</i>	24
7.4	<i>Spare parts</i>	25

# 1 BASIC SAFETY INSTRUCTIONS

The CS 352 is exclusively designed for the cutting of floors made of asphalt, green and cured concrete (reinforced or not) as well as of industrial cement.

Uses other than the manufacturer's instructions shall be considered as contravening the regulations. The manufacturer shall not be held responsible for any resulting damage. Any risk shall be borne entirely by the user. Observing the operating instructions and compliance with inspection and servicing requirements shall also be considered as included under use in accordance with the regulations.

## 1.1 Symbols

Important warnings and pieces of advice are indicated on the machine using symbols. The following symbols are used on the machine:



Read operator's instructions



Ear protection must be worn



Hand protection must be worn



Eye protection shall be worn



Cutting depth indicator



Danger: risk of cut

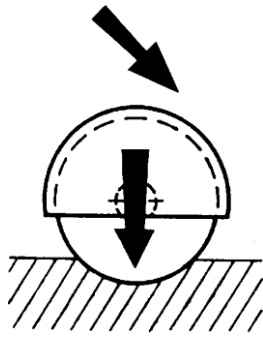

Rotation of the wheel in the indicated direction lowers the blade

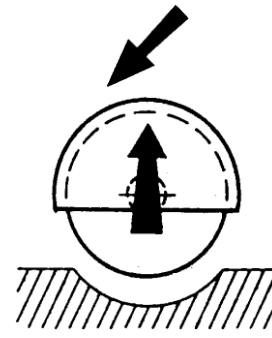

Rotation of the wheel in the indicated direction raises the blade

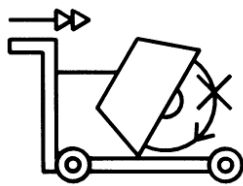

Never move the machine with the blade running idle.







Rotation direction of the blade



Emergency Stop

## 1.2 Machine plate

Important data can be found on the following plate located on the machine:

 SAINT-GOBAIN 190, Bd. J.F. Kennedy L-4930 BASCHARAGE LUXEMBOURG	Code: Machine Code	Year: Year of production	 = Ø Maximum blade mm	UK CA CE EAC
	Mod: Machine Model	W= Weight kg	 = Ø Bore mm	
	EN: Safety standard	P= Power kW	 = Blade speed RPM	
	Type: Machine type	Serial N°: Serial number		

### **1.3 Safety instructions for particular operating phases**

#### **Before commencing work**

- Before commencing work, make yourself familiar with the working environment at the place of use. The working environment includes: obstacles in the area of work and manoeuvre, the firmness of the floor, necessary protection at the site relating to public thoroughfares and the availability of help in the event of accidents.
- Check for correct mounting of the blade regularly.
- Immediately remove damaged or badly worn blades, as they endanger the operator whilst rotating.
- Only fit NORTON diamond blades to the machine! The use of other tools can damage the machine!
- Attention is drawn to the use of BS2092 safety goggles in conformity with specified Processes No.8 of the Protection of Eyes Regulation 1974, Regulation 2(2) Part 1.
- For security reasons, never leave the machine unattended, untied or unlocked.

#### **While the engine is running**

- Do not move the machine whilst the blade is running idle.
- Always cut with the blade guard in position.
- Apply cooling water continuously whilst cutting and in good time!

#### **Petrol powered machines:**

- Always use the fuel advised.
- In confined areas, exhaust gases should be evacuated and the job site properly aerated.
- Petrol and diesel machines, which by their nature emit toxic exhaust gases, must not be used in places prohibited by the Health at Work etc. Act 1974 or which are prohibited by Factory Inspectors or Safety Officers.
- Fuel is flammable. Before filling the tank, shut down the engine, extinguish all open flames and do not smoke. Take care that no petrol is spilled on any motor part. Always wipe up spilled fuel.

## 2 GENERAL DESCRIPTION OF THE CS 352

Any modification, which could lead to a change in the original characteristics of the machine, may be done only by Saint-Gobain Abrasives S.A. who shall confirm that the machine is still in conformity with the safety regulations. Saint-Gobain Abrasives S.A. keeps the right of making technical or design modification without prior notification.

### 2.1 *Short description*

The **Floor Saw CS 352** you have chosen, is used for small repair works in concrete and asphalt, for cutting induction loops and installing cables as well as for cutting expansion joints. It can be used for either wet or dry cutting operations.

Being of small construction, it can be transported in a car or van, the handle can be removed, reversed or retracted. The water container is also removable.

All component parts on **the CS 352** are assembled to a high quality standard, ensuring long life, reliability and a minimum of maintenance.

Special types of blades are available for asphalt, green concrete, cured concrete (reinforced or not) as well as for industrial cement flooring.

## 2.2 Layout

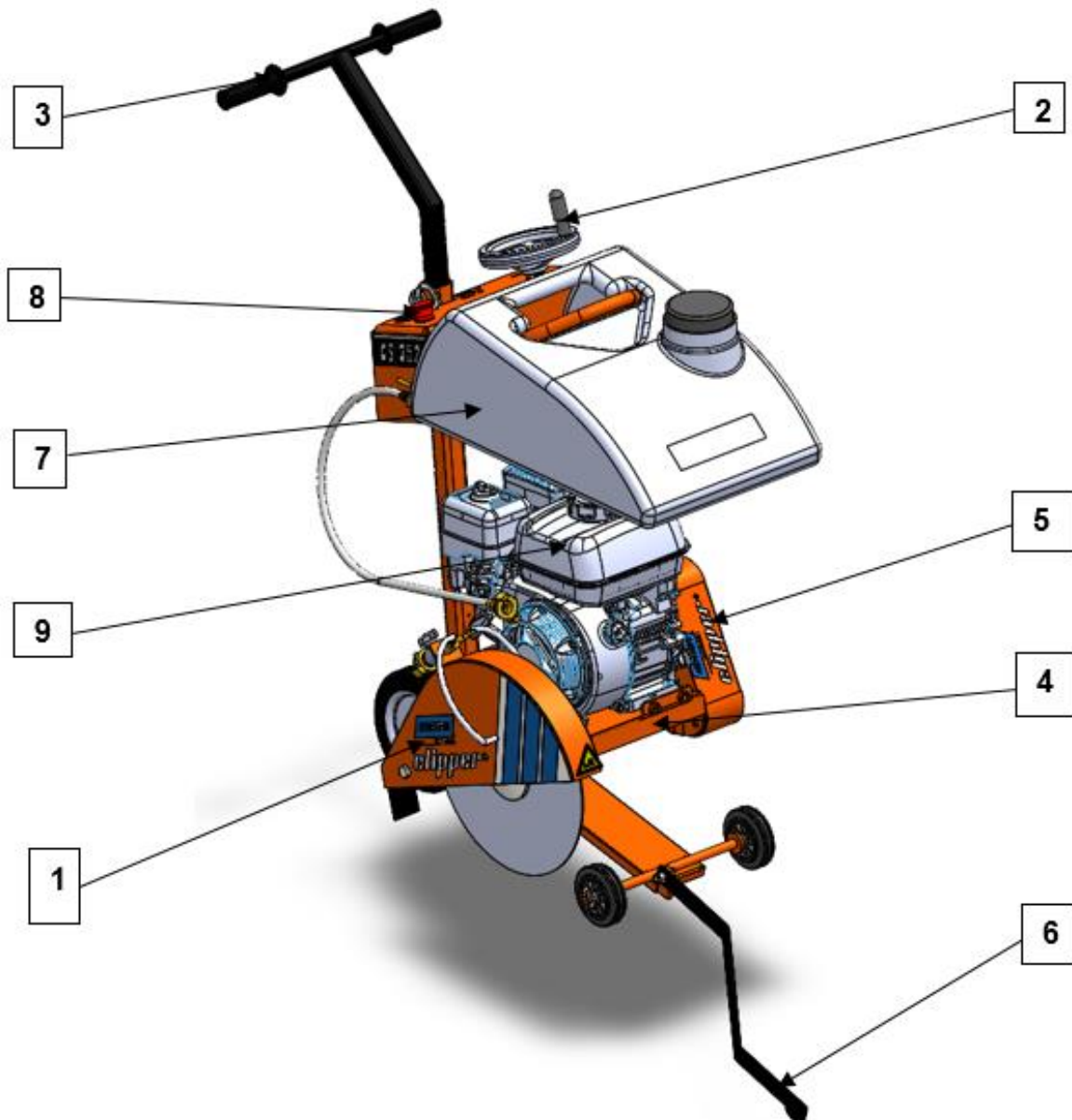

Made of jig welded open profile steel, the **CS 352** is stable but at the same time, easily transportable.

The one-piece blade guard (1) fully protects the operator and his working environment. It is firmly fixed to the main frame but can be opened by rotation to change blades.

A manually operated hand wheel mechanism (2) enables graduated depth setting. Turning the hand wheel clock- or anti-clockwise will raise or lower the cutting blade.

The handle (3) is detachable or can be reversed for easy transportation. The height is adjustable.

The motor frame (4), supporting the blade shaft, the motor, the blade guard and the belt guard, is articulated on the rear axle.

The precisely manufactured blade shaft is fitted into two heavy-duty self-aligning pillow block bearings, including grease nipples.

The steel belt guard (5) is a sealed two pieces unit. The backing plate is bolted to the mainframe of the machine and two locking nuts are welded to it. The outer guard, covering the three drive belts and taper lock pulleys, is held in place by two locking bolts.

The pointer (6) allows the operator to make precise cut easily.

The water tank (7), with a capacity of 25 litres, can be easily removed from the machine, allowing the tank to be refilled without having to move the machine.

The machine has a GX200 Honda engine (9), with 6,5HP. An emergency shut down switch (8) near the levers allows an immediate stop of the machine in case of danger.

### 2.3 Technical data

Engine	Honda GX200, 4 strokes, 1 cylinder, 6,5HP (4,8kW)
Filter	Cyclone Filter
Fuel	Regular unleaded
Oil	Honda 4-Stroke, or equivalent high detergent, premium quality motor oil certified to meet or exceed U.S. automobile manufacturer's requirement for service classification SG, SF. (SG, SF designated on the oil container). SAE 10W-30 recommended
Starter	Manual pull chord
Max. blade diameter	350 mm
Bore	25,4 mm
Max. cutting depth mm	115 mm
Flange diameter	100 mm
Blade shaft speed	2800 min <sup>-1</sup>
Driving belts	3
Water tank	25 l
Machine dimensions	900x520x970 mm
Weight	69 kg
Max. operating weight	98 kg
Sound pressure level	84 dB (A) (ISO EN 11201)
Sound energy level	100 dB (A) (ISO EN 3744)
Vibrations	5,56 m/s <sup>2</sup> (ISO EN 12096)

## 2.4 Statement regarding the vibration emission

Declared value of vibration emission following **EN 12096**.

Machine Model / code	Measured value of vibration emission at m/s <sup>2</sup>	Uncertainty K m/s <sup>2</sup>	Tool used Model / code
<b>CS 352 P6.5 HONDA 70184632007</b>	5,56	1,04	Pro béton

- Values determined using the procedure described in the standard **EN 13862**.
- The measurements are made with new machines. Actual values may vary with site conditions, in terms of:
  - Materials worked
  - Wear Machine
  - Lack of maintenance
  - Inappropriate tool for application
  - Tool in poor condition
  - Unskilled operator
  - Etc...
- The exposure time to vibration is based on the performance of work (related to the adequacy Machine / Tool / worked material / operator)
- When evaluating risks due to hand-arm vibration, you need to take into account effective usage at rated power of machine during a full day of work; quite often you will realise that effective utilisation time represents around 50% of overall duration of work. You have to consider, of course, breaks, water feeding, preparation of work, time to move the machine, disk mounting...

## 2.5 Statement regarding noise emission

Declared value of noise emission following **EN ISO 11201** and **NF EN ISO 3744**.

<b>Machine Model / code</b>	<b>Sound Pressure level L<sub>Peq</sub> EN ISO 11201</b>	<b>Uncertainty K (Sound Pressure level L<sub>Peq</sub> EN ISO 11201)</b>	<b>Sound power level L<sub>Weq</sub> NF EN ISO 3744</b>	<b>Uncertainty K (Sound power level L<sub>Weq</sub> NF EN ISO 3744)</b>
<b>CS 352 P6.5 HONDA 70184632007</b>	84 dB(A)	2.5 dB(A)	100 dB(A)	4 dB(A)

- Values determined using the procedure described in the standard **EN 13862**.
- The measurements are made with new machines. Actual values may vary with site conditions, in terms of:
  - Wear Machine
  - Lack of maintenance
  - Inappropriate tool for application
  - Tool in poor condition
  - Unskilled operator
  - Etc...
- Measured values relate to an operator in normal use, as described in the manual position.

### **3 ASSEMBLY AND COMMISSIONING**

Before beginning the work with the CS 352, you have to assemble some parts.

#### **3.1 Assembly**

Secure the operator's handle in a comfortable user position by using the locking nut.

#### **3.2 Tool assembly**

Only use NORTON blades with the CS 352.

A blade with a maximum diameter of 350 mm can be fitted in the CS 352.

All tools used must be selected with regard to their maximum permitted cutting speed for the machine's maximum permitted rotation speed.

Before mounting a new blade, switch the machine off.

To mount a new blade, follow these steps:

- Turn the wheel until the cutting head is in the raised position.
- Disconnect the water tank.
- Loosen the side screw and remove the blade guard.
- Loosen the hexagonal nut on the blade shaft, which holds the removable outer flange.
- Remove the outer flange.
- Clean the flanges and blade shaft and inspect for wear.
- Mount the blade on the shaft ensuring that direction of rotation is correct. Wrong direction of rotation blunts the blade quickly.
- Replace outer blade flange.
- Tighten hexagonal nut with spanner supplied for this purpose.
- Remount the blade guard.

The blade bore must correspond exactly to the blade shaft. Cracked or damaged bore is dangerous for the operator and for the machine.

#### **3.3 Water cooling system**

Fill the water tank with clean water.

Open water-tap at blade guard (note that handle on water-tap should be in line with water-flow).

Ensure that water is flowing freely in the circuit and delivered adequately to both sides of the blade, as insufficient water supply may result in premature failure of the diamond blade.

In case of frost, empty the water cooling system.

### 3.4 Starting the machine

Make sure the blade is raised clear up the ground before starting the machine.

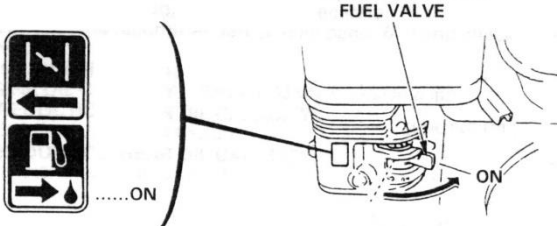
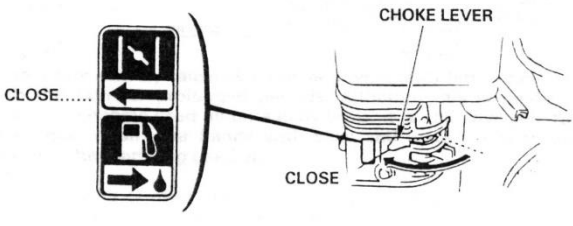
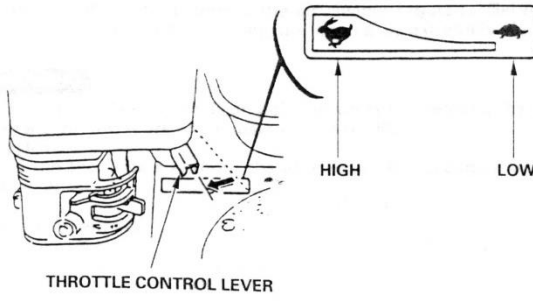
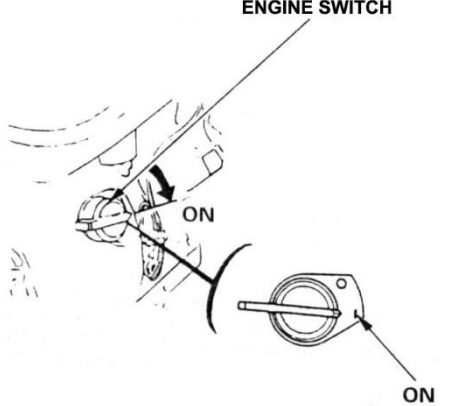
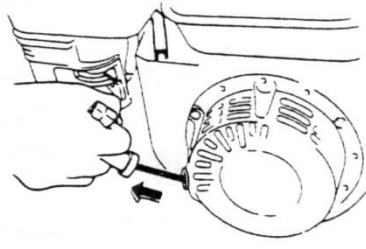
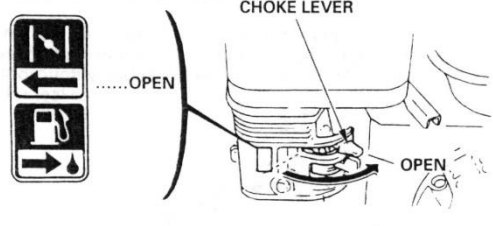
	
<p>Turn the fuel valve to the ON position.</p>	<p>Move the choke lever to the CLOSED position. NOTE: do not use the choke if the engine is warm or the air temperature is high.</p>
	
<p>Move the throttle control lever slightly to the left.</p>	<p>Put the engine switch on ON, and make sure the emergency switch on the board of the machine is in the correct position.</p>
	
<p>Pull the starter grip lightly until you feel resistance, then pull briskly. CAUTION: Do not allow the starter grip to snap back against the engine. Return it gently to prevent damage to the starter.</p>	<p>As the engine warms up, gradually move the choke lever to the OPEN position. Position the throttle control lever for the maximum engine speed.</p>

To stop the engine, move the throttle control lever fully to the right, then turn the engine switch to the OFF position. Turn the fuel valve to the OFF position.

## 4 OPERATING THE CS 352

### 4.1 Site of work

Before you start working, please check the following points:

- Remove from the site anything, which might hinder the working procedure.
- Make sure the site is sufficiently well lit.
- Make sure you have a continual adequate view of the working area so you can intervene in the working process at any time.
- Keep other staff out of the area, so you can work securely.

### 4.2 Cutting method

In this section, you can find instructions to make a straight cut at the desired depth.

#### 4.2.1 Preparing your cut

Before starting the machine,

- Draw a line on the floor over the cutting length.
- Make sure you have filled the engine tank with fuel, and the water tank with water. No petrol is supplied with the machine.
- The engine is shipped with oil. Check oil level before starting. Top up if required.
- Make sure you have mounted the correct blade as recommended by the manufacturer depending on the material to be worked, the working procedure (dry or wet cut) to be carried out, and the efficiency required.
- Make sure that the flanges securely hold the diamond blade.
- Make sure that the blade is not touching the floor before starting.
- Bring the handle in a comfortable position.
- Roll the machine until the blade is over the line.
- Lower the guide-a-cut so it touches the line.

#### 4.2.2 Cutting the floor

You can now start the engine. To make your cut,

- Turn on the water tap according to the type of blade used and the cut required:
  - Water cutting: a sufficient amount of water should be used continuously throughout the cutting process to cool the disc properly.
  - Dry cutting: if possible, a small amount of water should be used to limit the creation of dust.
- Turn the depth hand wheel until the blade slightly touches the floor.
- To lower blade into the cut, turn hand wheel anti-clockwise. Each turn of the hand wheel will raise or lower the blade by 7.5mm.
- Push the machine forward with steady and gentle pressure and follow the line with the pointer. The feed speed must be adjusted depending on the material being cut, and depth of cut.
- At the finish of the cut, raise the blade out of the cut by turning the hand wheel clockwise, shut-off the water and switch off the engine.

## 5 TRANSPORT AND STORING

Take the following measures in order to transport and store the CS 352 securely.

### 5.1 *Securing for transport*

Before transporting the machine:

- Remove the blade.
- Empty the water tank.
- Lower the handle in its fixing tube and secure it using the locking nut.
- Raise the guide-a-cut in its upright position.
- Raise the cutting head to its highest position using the hand wheel.

### 5.2 *Transport procedure*

The machine can be moved on a flat surface using its wheels. Only use the lifting hook on the water tank support to suspend the machine. The use of any other device (especially the handle) to suspend the machine is absolutely forbidden.

### 5.3 *Long period of inactivity*

If the machine is not going to be used for a long period, please take the following measures:

- Completely clean the machine.
- Loosen the drive belts.
- Grease the threaded shaft.
- Possibly change the motor oil.
- Empty the water system.

The storage site must be clean, dry and at a constant temperature.

## 6 MAINTENANCE AND SERVICE

**ATTENTION:** to perform maintenance on the machine, always switch it off. Always wear a face mask and safety goggles while performing the maintenance of machine.

### 6.1 Maintenance of the machine

To ensure a long-term quality from the cutting with the CS 352, please follow the maintenance plan below:

		Regular service period Perform at every indicated period →						
		After one hour of work	Begin of the day	During the changing of the tool	End of the day	Every week	After a fault	After a damage
Whole machine	Visual control (general aspect, watertightness)							
	Clean							
Flange and blade fixing devices	Clean							
Belts tension	Control							
Water hoses and nozzles	Clean							
Depth screw	Grease							
Engine housing	Clean							
Reachable nuts and screws	Tighten up							

#### Adjustment and replacement of the belts

After one hour of work, the belts heat and stretch. Therefore, you have to re-tension them.

To adjust the belts, firstly remove the belt guard by unscrewing the 2 nuts. Loose the 4 engine bolts and shift the engine by using the two screws on the front.

To replace the belts, move the engine completely to the front. Adjust the belts and retighten them by shifting the motor to the rear.

Always use a matched set of belts. Do not replace single belts.

#### Lubrication

The CS 352 uses life-lubricated bearings. Therefore, you don't need to lubricate them at all.

Grease the depth screws every day.

#### Cleaning of the machine

Your machine will last longer if you clean it thoroughly after each day of work.

## 6.2 Maintenance of the engine

		Each use	First month or 20 hours	Every 3 months or 50 hours	Every 6 months or 100 hours
<p><b>Regular service period</b> Perform at every indicated month or operating hour interval, whichever comes first</p> <p style="text-align: right;">→</p>					
Engine oil	Check level				
	Change				
Air cleaner filter	Check				
	Clean				
Fuel strainer cup	Clean				
Spark plug	Check-Clean				
Fuel line	Check (Replace if necessary)	Every 2 years			

### Engine oil

To change the oil,

- Remove the oil filler cap/dipstick and drain bolt.
- Allow the oil to drain completely.
- Dispose of used motor oil in a manner that is compatible with the environment. We suggest you to take used oil in a sealed container to your local recycling centre or service station for reclamation. Do not throw it in the trash, pour it on the ground or down in a drain.
- Reinstall the drain bolt, and tighten it to 18 N.m.
- Fill the crankcase with the engine oil to the outer edge of the oil filler neck.
- Reinstall the filler cap/dipstick.

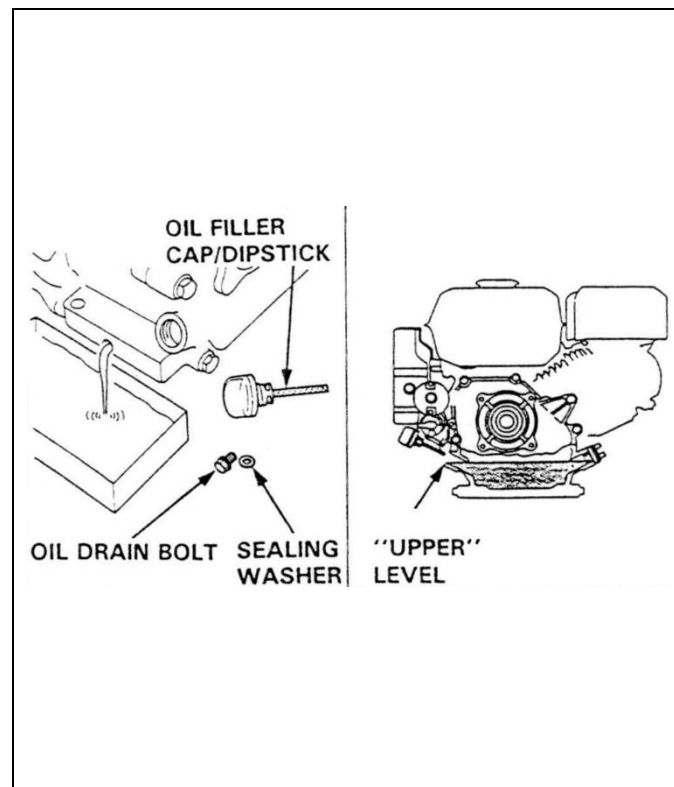

## Air cleaner

The CS 352 has a Cyclone filter.

To service the air cleaner filter, follow these instructions:

- Remove the nut, air cleaner cover and wing nut.
- Remove the pre air cleaner elements and separate them.
- Carefully check both elements for holes or tears and replace if damaged.
- **Paper element:** tap element lightly several times on a hard surface to remove excess dirt or blow compressed air lightly through the filter from the inside out. Never brush the dirt off; brushing will force dirt into the fibres.
- **Foam element:** clean in warm soapy water, rinse and allow to dry thoroughly. Dip the element in clean engine oil and squeeze out all the excess. The engine will smoke during initial start-up if too much oil is left in the foam.
- Shine a light through the elements, and inspect them carefully. Reinstall the elements if they are free of holes and tears.

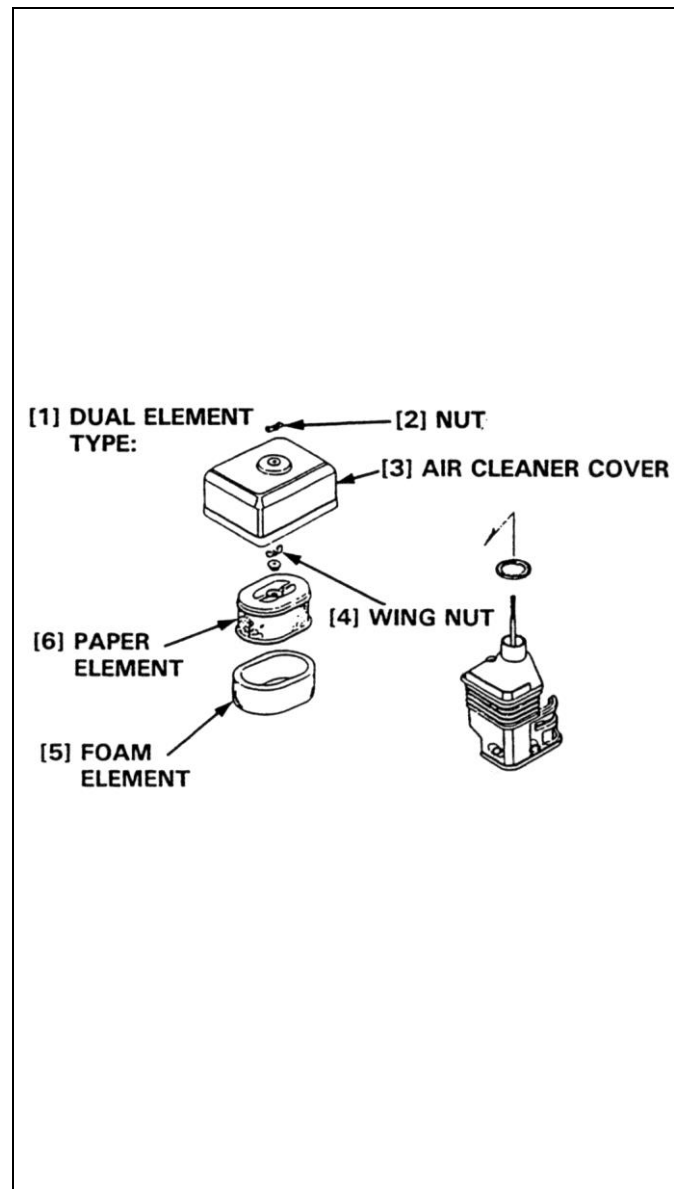

## Fuel strainer cup

To service fuel strainer cup, follow these instructions:

- Turn off the fuel valve and remove the strainer cup.
- Clean the strainer cup with solvent.
- Install the O-ring and strainer cup.
- Tighten the strainer cup to 4N.m.

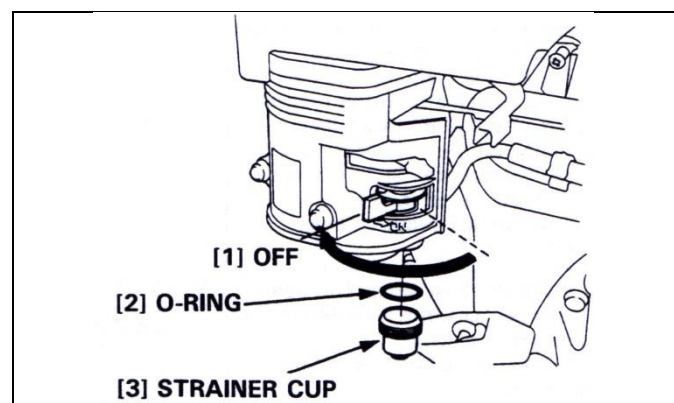

## Spark plug

To service the spark plug, follow these instructions:

- Visually inspect the spark plug. Discard the plug if the insulator is cracked or chipped.
- Remove carbon or other deposits with a stiff wire brush.
- Measure the plug gap with a wire-type feeler gauge. If necessary, adjust the gap by bending the side electrode.
- Make sure the sealing washer is in good condition; replace the plug if necessary.
- Install the plug fingertight to seat the washer, then tighten with a plug wrench (an additional  $\frac{1}{2}$  turn if a new plug) to compress the sealing washer. If you are reusing a plug, tighten  $\frac{1}{8}$ - $\frac{1}{4}$  turn after the plug seats.

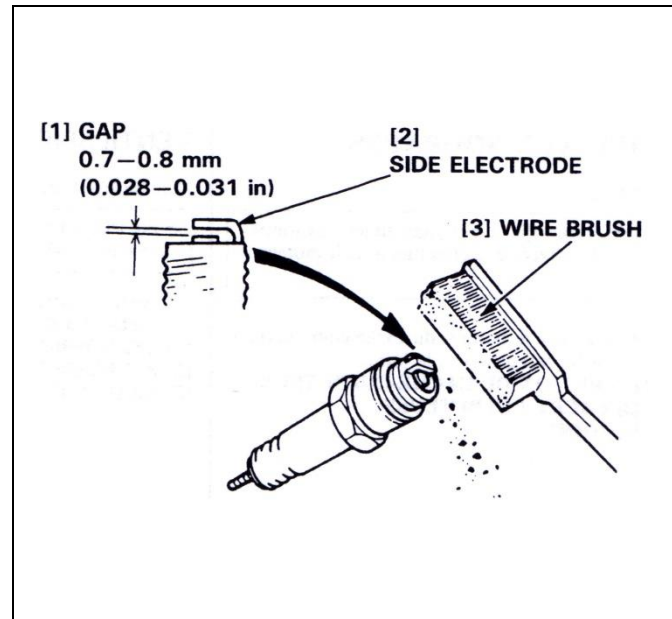

## Fuel line

To service the fuel line, follow these instructions:

- Drain the fuel into a suitable container, and remove the fuel tank.
- Disconnect the fuel line, and unscrew the fuel filter from the tank.
- Clean the filter with solvent, and check, that the filter screen is undamaged.
- Place the O-ring on the filter and reinstall. Tighten the filter to 2N.m. After reassembly, check for fuel leaks.

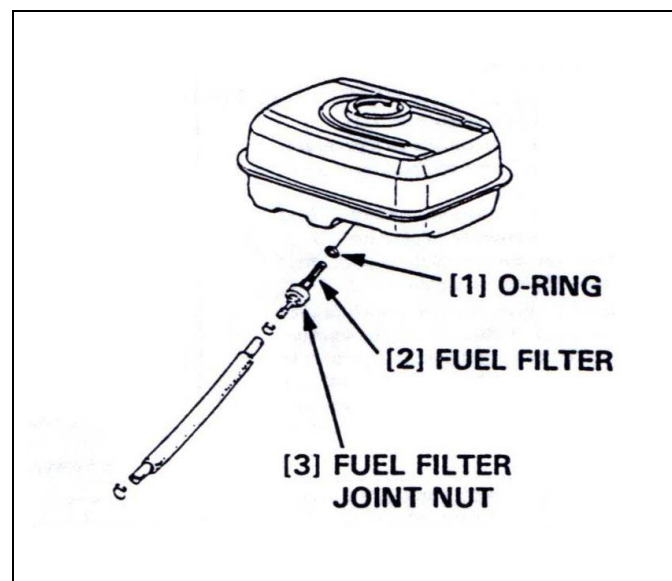

## Further maintenance

For further maintenance, please contact the nearest engine maintenance centre.

## 7 FAULTS: CAUSES AND CURES

### 7.1 *Fault-finding procedures*

Should any fault occur during the use of the machine, turn it off. Let only qualified staff make any intervention other than the one described in the previous section.

### 7.2 *Trouble-shooting guide*

Trouble	Possible source	Resolution
Hard starting	Not enough fuel	Fill fuel tank
	Fuel filter clogged	Clean fuel filter
	Spark plug faulty	Inspect spark plug
	Stronger fault	Contact nearest engine maintenance centre
Engine lacks power	Air filter restricted	Clean or replace air filter
	Stronger fault	Contact nearest engine maintenance centre

### **7.3 Customer service**

When ordering spare parts, please mention:

- The serial number (7 digits).
- The code of the part.
- The exact denomination.
- The number of parts required.
- The delivery address.
- Please indicate clearly the means of transportation required such as "express" or "by air". Without specific instructions, we will forward the parts through the means which seem appropriate to us --- but which is not always the quickest way.

Clear instructions will avoid problems and faulty deliveries.

If not sure, please send us the defective part.

In the case of a warranty claim, the part must always be returned for evaluation.

Spare parts for the motor can be ordered with the manufacturer of the motor or with their dealer, which is often quicker and cheaper.

This machine has been manufactured by: Saint-Gobain Abrasives S.A.

190, Bd. J. F. Kennedy

L- 4930 BASCHARAGE

Grand-duché de Luxembourg.

Tel.: 00352-50 401-1

Fax: 00352- 50 16 33

<http://www.construction.norton.eu>

e-mail: [sales.nlx@saint-gobain.com](mailto:sales.nlx@saint-gobain.com)

## 7.4 Spare parts

In order to consult the spare parts lists, we invite you to visit the after-sales website of Norton Clipper by using the following address:

<https://spareparts.nortonabrasives.com>

For a quick access, you can also use the QR Code shown below using your mobile phone:



This electronic catalogue provides exploded views and spare parts lists for different machines designed by Norton Clipper so you can find references you need.

Guarantee can be claimed and technical support obtained from your local distributor where machines, spare parts and consumables can be ordered as well:





SAINT-GOBAIN ABRASIVES  
INDUSTRIEWEG 21  
9420 ERPE-MERE  
BELGIUM  
TEL: +32(0) 2 267 21 00

SAINT-GOBAIN CONSTRUCTION  
PRODUCTS CZ A.S  
DIVIZE ABRASIVES  
SMRČKOVA 2485/4  
180 00 PRAHA 8  
CZECH REPUBLIC  
TEL: +420 255 719 326  
FAX: +420 255 719 321

SAINT-GOBAIN ABRASIVES A/S  
DYBENDALSVEJENGET 2,  
DK-2630 TAASTRUP  
DENMARK  
TEL: +45 4675 5244

PO BOX 643706  
FORTUNE TOWER OFFICE 2106  
JLT BLOCK C  
(NEXT TO METRO STATION)  
JUMEIRA LAKE TOWER, DUBAI  
UNITED ARAB EMIRATES  
TEL: +971 4 431 5154  
FAX: +971 4 431 5434

SAINT-GOBAIN ABRASIFS  
RUE DE L'AMBASSADEUR - B.P.8  
78 702 CONFLANS CEDEX  
FRANCE  
TEL: +33 (0)1 34 90 40 00  
FAX: +33 (0)1 39 19 89 56

SAINT-GOBAIN ABRASIVES GMBH  
BIRKENSTRASSE 45-49  
D-50389 WESSELING  
GERMANY  
TEL: +49 (0) 2236 703-0  
FAX: +49 (0) 2236 703-730

SAINT-GOBAIN ABRASIVES KFT.  
1225 BUDAPEST  
BÁNYALÉG U. 60/B.  
HUNGARY  
TEL: +36 1 371 22 50  
FAX: +36 1 371 22 55

SAINT-GOBAIN ABRASIVI S.P.A  
VIA PER CESANO BOSCONI 4  
I-20094 CORSICO MILANO  
ITALY  
TEL: +39 02 44 851  
FAX: +39 02 44 78 266

SAINT-GOBAIN ABRASIVES S.A.  
190 RUE J.F. KENNEDY  
L-4930 BASCHARAGE  
GRAND DUCHE DE LUXEMBOURG  
TEL: +352 50 401 1  
FAX: +331 83 717 792  
NO. VERT (FRANCE): 0800 906 903

SAINT-GOBAIN ABRASIFS, S.A.  
2 ALLÉE DES FIGUIERS  
AIN SEBAË - CASABLANCA  
MOROCCO  
TEL: +212 5 22 66 57 31  
FAX: +212 5 22 35 09 65

SAINT-GOBAIN ABRASIVES BV  
GROENLOSEWEG 28  
7151 HW EIBERGEN  
P.O. BOX 10  
7150 AA EIBERGEN  
THE NETHERLANDS  
TEL: +31 545 466466  
FAX: +31 545 474605

SAINT-GOBAIN ABRASIVES AS  
KARIHAUGVEIEN, 89  
0186 OSLO  
NORWAY  
TEL: +47 63 87 06 00  
FAX: +47 63 87 06 01

SAINT-GOBAIN HPM POLSKA SP. Z O.O.  
UL. NORTON 1, 62-600 KOŁO  
62-600 KOŁO  
POLAND  
TEL: +48 63 26 17 100  
FAX: +48 63 27 20 401

SAINT-GOBAIN ABRASIVOS, L. DA  
ZONA INDUSTRIAL DA MAIA  
I-SECTOR VIII, NO. 122  
APARTADO 6050  
4476 - 908 MAIA  
PORTUGAL  
TEL: +351 229 437 940  
FAX: +351 229 437 949

SAINT-GOBAIN GLASS  
BUSINESS UNIT ABRASIVI  
PUNCT DE LUCRU : LOC.VETIS, JUD.  
SATU MARE 447355  
STR. CAREIULUI 11  
PARC INDUSTRIAL RENOVATIO  
ROMANIA  
TEL: +40 261 839 709  
FAX: +40 261 839 710

SG HPM RUS  
58, F. ENGELS STR.  
STROENIE 2  
105082 MOSCOW  
RUSSIA  
TEL: +74 955 408 355  
FAX: +74 959 373 224

SAINT-GOBAIN  
ABRASIVES (PTY) LTD  
2 MONTEER ROAD  
ISANDO 1600  
P.O. BOX 67  
SOUTH AFRICA  
TEL: +27 11 961 2000  
FAX: +27 11 961 2184/5

SAINT-GOBAIN ABRASIVOS, S.A.  
CTRA. DE GUIPÚZCOA, KM. 7,5  
E-31195 BERRIOPLANO (NAVARRA)  
SPAIN  
TEL: +34 948 306 000  
FAX: +34 948 306 042

SAINT GOBAIN ABRASIVES AB  
GÅRDSFOGDEVÄGEN 18A  
168 66 BROMMA • SVERIGE  
SWEDEN  
TEL: +46 8 580 881 00  
FAX: +46 8 580 881 30

SAINT-GOBAIN INOVATIF MALZEMELER  
VE ASINDIRICI SAN. TIC. AS.  
ALTAYÇEŞME MAH. ÇAMLI SOK. NO:21  
ESAS OFIS PARK KAT:9 34843  
MALTEPE, İSTANBUL • TURKEY  
TEL: 0090-216-217 12 50  
FAX: 0090-216-442 40 74

SAINT-GOBAIN ABRASIVES LTD.  
UNICORN HOUSE UNIT 1, AMISON CLOSE  
REDHILL BUSINESS PARK  
STAFFORD ST161WB  
UNITED KINGDOM  
TEL: +44 1785 279 553  
FAX: +44 1785 213 487



Saint-Gobain Abrasifs  
190 Rue J.F. Kennedy  
L-4930 Bascharage  
Grand Duché de Luxembourg  
Tel: +352 50 4011  
Fax: +331 83 717 792  
no. vert (France) 0800 906 903

[www.nortonabrasives.com/fr-fr](http://www.nortonabrasives.com/fr-fr)