

CWM 216 / 254

OPERATING INSTRUCTIONS

Translation of the original instructions

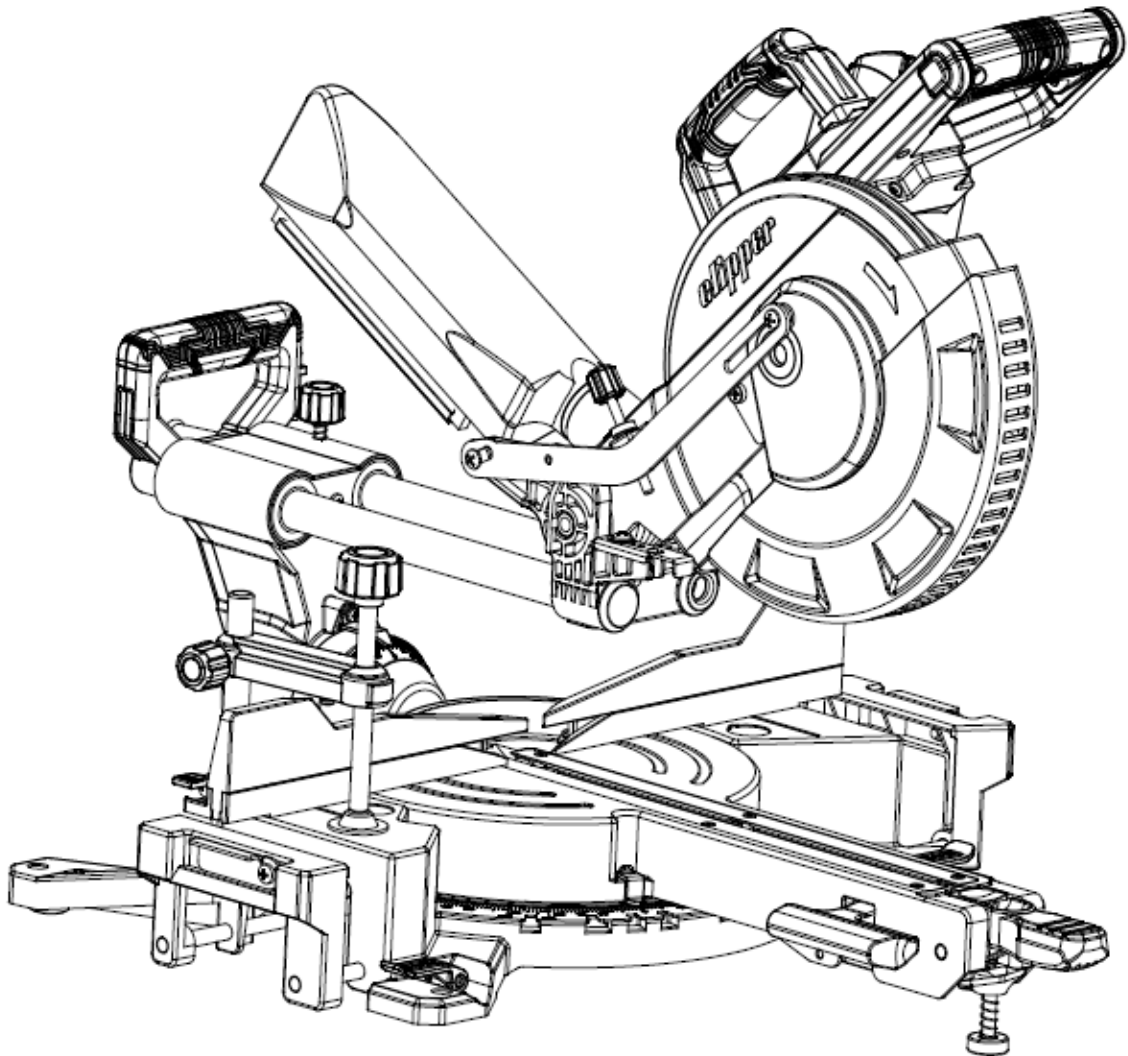

NORTON

SAINT-GOBAIN

clipper





Declaration of conformity

The undersigned manufacturer:

SAINT - GOBAIN ABRASIVES S.A.
190, BD J.F. KENNEDY
L- 4930 BASCHARAGE

Declares that this product:

Mitre Saws: **CWM 216 230V**
CWM 254 230V

Code: **70184608463**
70184608464

is in conformity with the following Directives:

- **"MACHINES" 2006/42/CE**
- **"ÉLECTROMAGNÉTIQUE COMPATIBILITÉ" 2014/30/CE**
- **"NOISE" 2000/14/CE**

and European standard:

- **EN 62841-1**

Valid for machines as of serial number: 4502790460000

Storage site for the technical documents:

Saint-Gobain Abrasives 190, Bd. J. F. Kennedy 4930 BASCHARAGE, LUXEMBOURG

This declaration of conformity loses its validity when the product is converted or modified without agreement.

Bascharage, Luxembourg, 16.03.2023

François Chianese, executive officer and responsible for the technical file.
Bascharage, Luxembourg.

CWM 216/254

OPERATING INSTRUCTIONS

TABLE OF CONTENTS

1 BASIC SAFETY INSTRUCTIONS	6
1.1 <i>Machine plate</i>	7
1.2 <i>Safety instructions for particular operating phases</i>	8
1.3 <i>Short description</i>	9
1.4 <i>Purpose of use</i>	9
1.5 <i>Layout</i>	9
1.6 <i>Technical data</i>	18
1.7 <i>Statement regarding noise emission</i>	18
1.8 <i>Electrical connections</i>	18
1.9 <i>Starting the machine</i>	18
2 TRANSPORT AND STORING	19
2.1 <i>Securing for transport</i>	19
2.2 <i>Storing of the machine</i>	19
3 OPERATING THE MACHINE	20
3.1 <i>Installation</i>	20
3.2 <i>Maintenance</i>	20
4 BREAKDOWN – CAUSES AND CURES	21
4.1 <i>Breakdown-finding procedures</i>	21
4.2 <i>Trouble-shooting guide</i>	21
4.3 <i>Customer service</i>	<i>Erreur ! Signet non défini.</i>
4.4 <i>Spare parts</i>	<i>Erreur ! Signet non défini.</i>
4.5 <i>Recycling and disposal</i>	23

1 BASIC SAFETY INSTRUCTIONS

The CWM 216/254 are Professional sliding miter saws for cutting work pieces such as areas of laminate, parquet, decking and floor boards as well as for furniture construction parts in non-ferrous materials.

Symbols

Important warnings and pieces of advice are indicated on the machine using symbols. The following symbols are used on the machine:



Read operator's instructions



Ear protection must be worn



Hand protection must be worn



Eye protection shall be worn



Wear a dust mask



Danger : keep your hands away



Danger : Laser Radiation

1.1 Machine plate

Important data can be found on the following plate located on the machine:

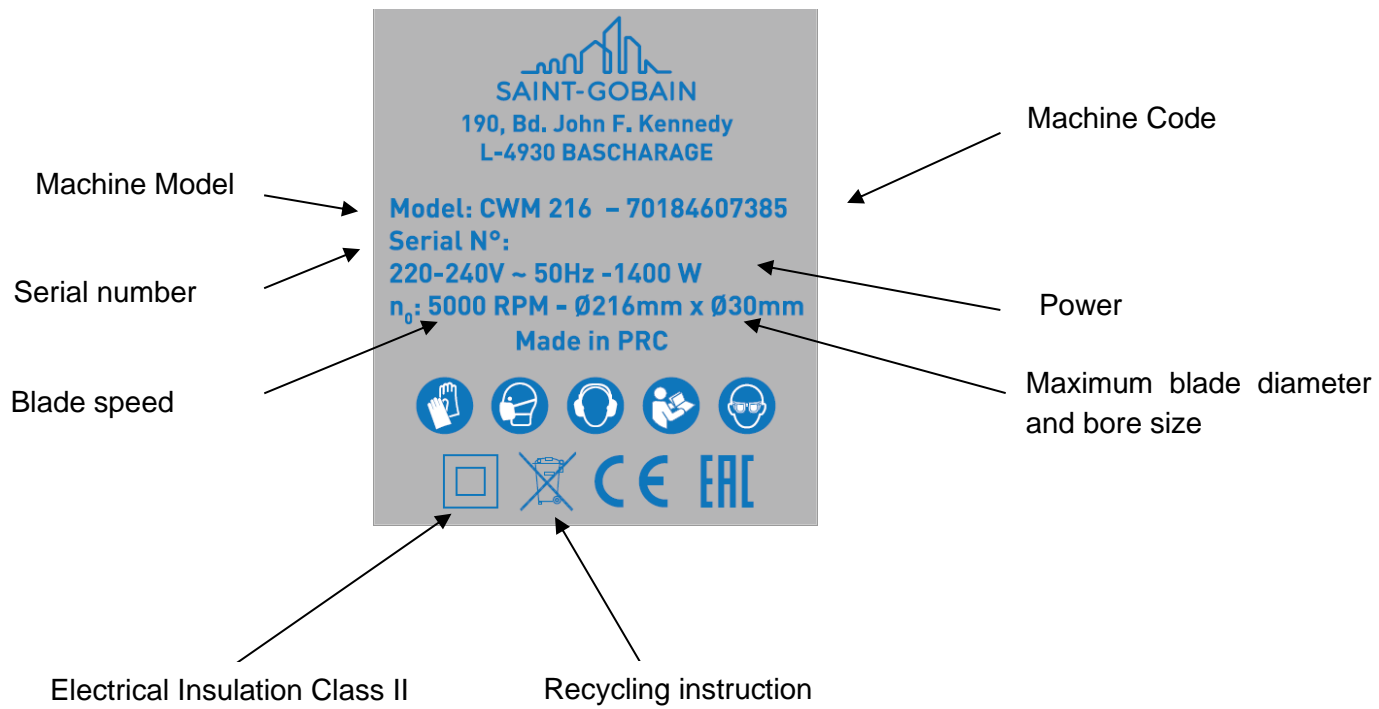

1.2 Safety instructions for particular operating phases

Before commencing work

- Before commencing work, make yourself familiar with the working environment at the place of use. The working environment includes: obstacles in the area of work and manoeuvre, the firmness of the floor, necessary protection at the site relating to public thoroughfares and the availability of help in the event of accidents.
- Check for correct mounting of the blade regularly.
- Immediately remove damaged or badly worn blades, as they endanger the operator whilst rotating.
- Only fit NORTON blades to the machine! The use of other tools can damage the machine!
- Please wear safety goggles and a dust mask to minimize the effects of dust.
- For security reasons, never leave the machine unattended, untied or unlocked.

While the motor running

- Do not move the machine whilst the blade is idling.
- Always cut with the blade guard in position.

SAFETY INSTRUCTIONS FOR LASER

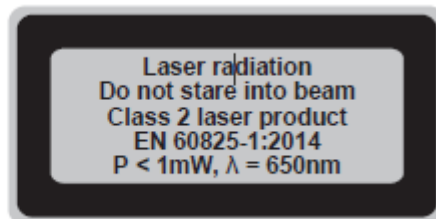

- a) Do not stare directly at the laser beam. A hazard may exist if you deliberately stare into the beam.
- b) The laser shall be used and maintained in accordance with the manufacturer's instructions.
- c) Never aim the beam at any person or an object other than the work piece.
- d) The laser beam shall not be deliberately aimed at another person and shall be prevented from being directed towards the eye of a person for longer than 0.25 seconds.
- e) Always ensure the laser beam is aimed at a study work piece without reflective surfaces, e.g. wood or rough coated surfaces are acceptable. Bright shiny reflective sheet or similar is not suitable for laser applications as the reflective surface may direct the laser beam back at the operator.
- f) Do not change the laser device with a different type. Repairs must be carried out by the manufacturer or an authorized agent.
- g) CAUTION: result in hazardous radiation exposure.

MACHINES DESCRIPTION

Any modification, which could lead to a change in the original characteristics of the machine, may be done only by Saint-Gobain Abrasives who shall confirm that the machine is still in conformity with the safety regulations.

1.3 Short description

The CWM 216/254 miter saws are designed for durability and high performance for onsite dry cutting operations of a wide range of wood and aluminium products. It can be used on construction or industrial site. Combined with NORTON Wood or aluminium blades, it offers high performance and quality cuts of materials used in construction. The machine and its component parts are assembled to high standards assuring long life and minimum maintenance.

1.4 Purpose of use

The CWM 216/254 are intended as a stationary machine for making straight lengthways and crossways cuts in wood and materials that are similar to wood (e. g. plywood, *Product. DF* and chipboard).

This product should not be used on other materials or those harmful to health. It is to be used for dry operation only without water or other cooling liquids. Observe all the instructions therein.

1.5 Layout

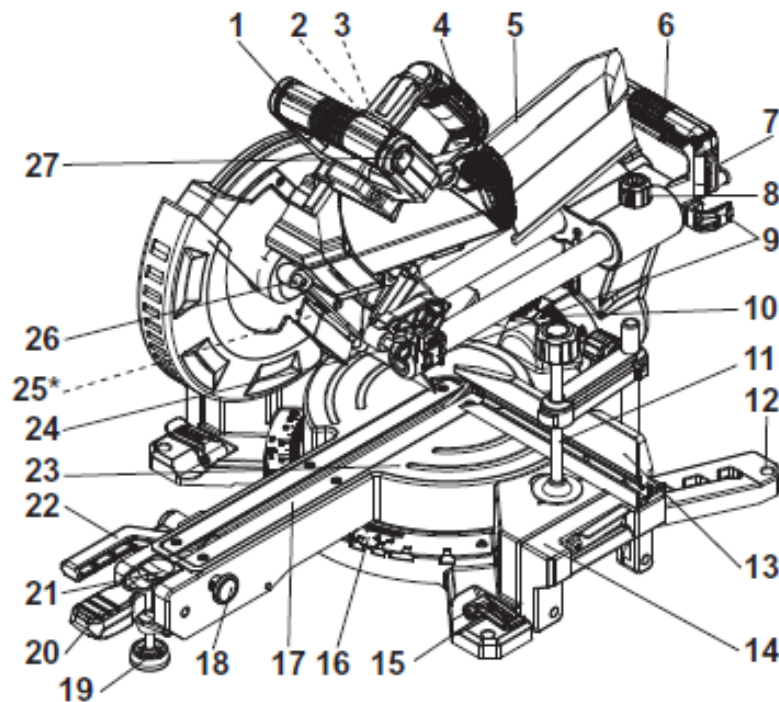

- | | |
|---|--|
| 1. Operating handle | 12. Mounting hole (X4) |
| 2. LED light switch | 13. Fence (left & right) |
| 3. Laser switch | 14. Extension supporter (left & right) |
| 4. Front transport handle | 15. Extension supporter locking lever (left & right) |
| 5. Dust collection bag | 16. Mitre scale |
| 6. Rear transport handle | 17. Table insert |
| 7. Multi tool (6 mm hex key/cross screw driver) | 18. Mitre angle adjustment lever locking knob |
| 8. Sliding locking knob | 19. Support bolt |
| 9. Power cord holder | 20. Turntable locking handle |
| 10. Bevel scale | |
| 11. Workpiece clamp | |

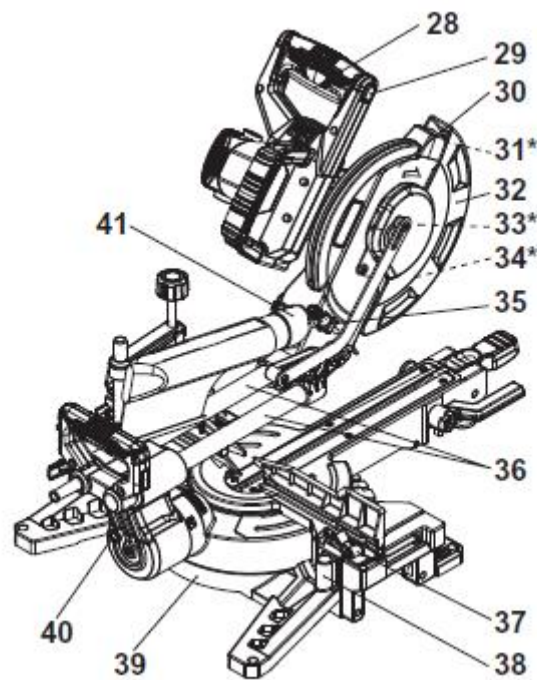

- | | |
|----------------------------------|---|
| 21. Mitre angle adjustment lever | 32. Lower retractable blade guard |
| 22. Bevel angle locking lever | 33. Guard mounting plate* |
| 23. Turntable | 34. Saw blade* |
| 24. Locking bolt | 35. Cutting depth gauge |
| 25. LED light* | 36. Sliding bar |
| 26. Spindle locking button | 37. Fence locking lever (left & right) |
| 27. Right safety lock button | 38. Workpiece clamp holder (left & right) |
| 28. On/off switch | 39. Base |
| 29. Left safety lock button | 40. Bevel angle locking knob |
| 30. Upper fixed blade guard | 41. Dust extraction outlet |
| 31. Laser* | |

Operating position (fig A)

1. Push the operating handle (1) (step 1) downwards and disengage the locking bolt (24) from its locking position (step 2).
2. Lift the operating handle (1) to its full height (step 3).

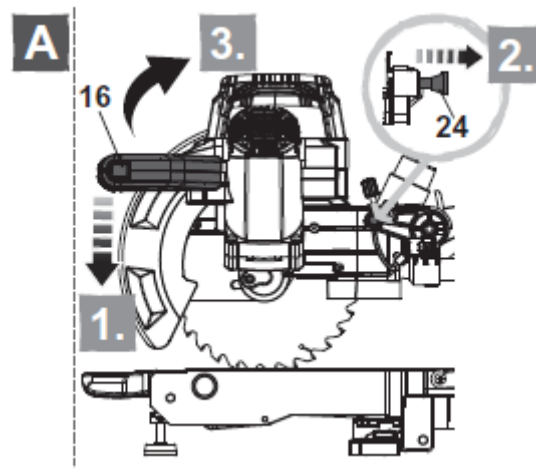

Work piece Clamp (fig B)

The work piece clamp (11) is pre-assembled. Insert the height adjustment pillar (11b) into the work piece clamp holder (38) on either side of the base if necessary.

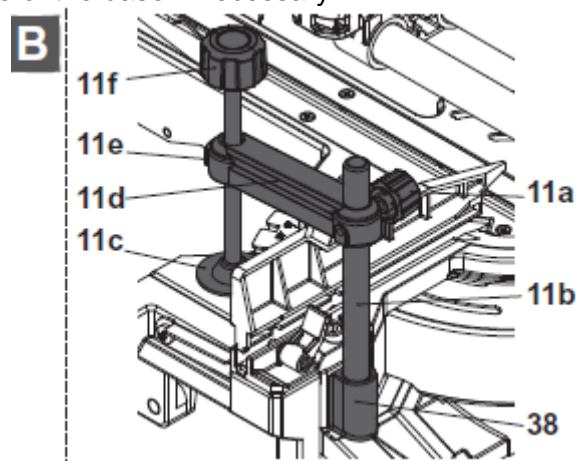

Fence (fig C)

Install:

1. Unlock the fence locking lever (37) (step 1).
2. Align the fence gaps (13a) with the screws (37a). Insert the fence (13) into the slot (step 2).
3. Slide the fence to the desired position (step 3).
4. Lock the fence locking lever (37) (step 4).

Uninstall:

1. Unlock the fence locking lever (37).
2. Slide the fence (13) to the end of the slot and remove it from the slot.

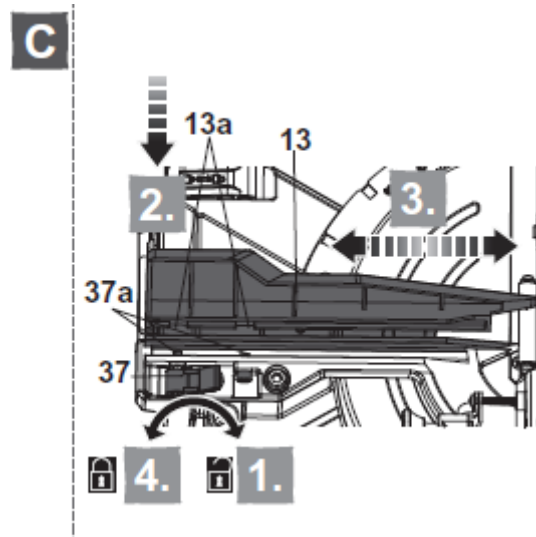

Replacing saw blade (fig D, E, F)

Follow these steps for replacing a worn or damaged saw blade:

1. Open the lower retractable blade guard (32) by hand to expose the locking screw (33a) of the guard mounting plate (33) (Fig. D step 1).
2. Loosen the locking screw (33a) with the provided multi tool (7) (Fig. D step 2) until the guard mounting plate (33) can be slid to the side (Fig. D step 3). For the Sliding Miter Saw, press down the operating handle (1) to help sliding.
3. Press the spindle locking button (26) fully and hold it in position. (Fig. E)
4. Turn the clamping screw (34a) slightly with the provided multi tool until the spindle is locked.
5. Loosen the clamping screw (34a) clockwise and remove it together with the washer the spindle (34d) (Fig. F).
6. Place a new saw blade on the spindle and make sure that the bore of the saw guard (30).
7. Secure the saw (34) with the outer flange (34c) washer(34b) and clamping screw (34a).
Tighten the clamping screw anti-clockwise with the provided multi tool while the spindle locking button (26) is pressed.
8. Turn the saw blade (34) by hand to test if it is rotating smoothly .IT should no flutter.
9. Push the lower retractable blade guard to slide the guard mounting plate (33) downward and tighten the locking screw (33a) with the provided multi tool.
10. Close the lower retractable blade guard (32) afterwards.

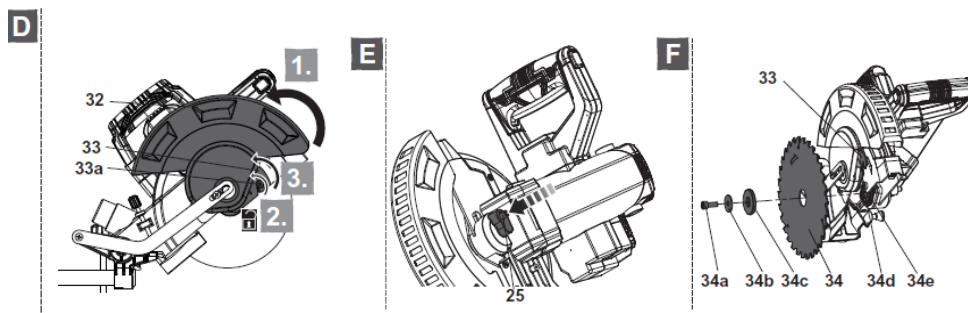

Bench mounting

There are 4 mounting holes (12) at each corner of the base (39) to facilitate bench mounting.

1. Place the miter saw over the workbench tabletop and mark four locations on top of the workbench that correspond to the mounting hole positions.
2. Drill four mounting holes (\varnothing 11 mm) at the marked location of the workbench.
3. Place the miter saw on the workbench and align the mounting holes of the base with the drilled holes in the workbench.
4. Firmly secure the miter saw to the bench surface with 4 bolts (not provided).
5. Carefully check the workbench after mounting to make sure that no movement can occur during use. If any tipping, sliding, or other movement is noted, secure the workbench to the floor before operating.

Dust Extraction (fig G, H, I)

The product can be used with the dust collection bag (5) or an external dust extraction device.

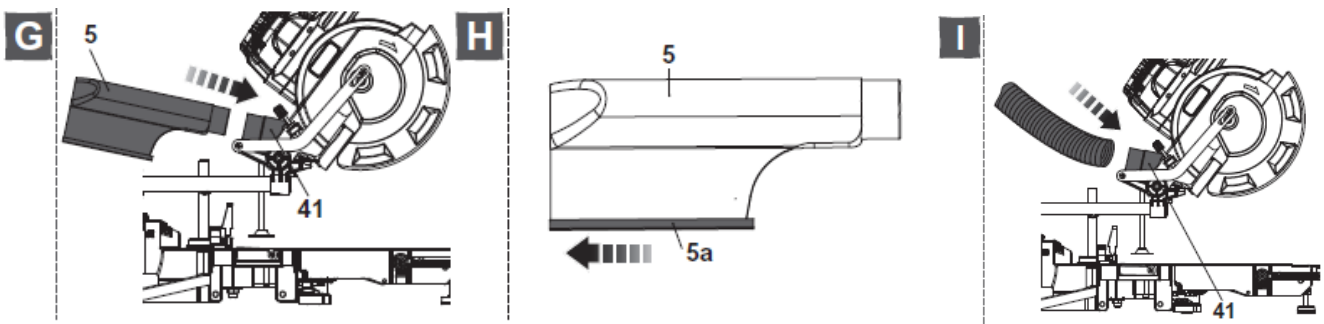

Dust collection Bag

1. Attach the dust collection bag (5) to the dust extraction outlet (41) (Fig. G).
2. Pull the dust collection bag off to remove it from the appliance.
3. To empty the dust collection box, open the bag by pulling out the sealing slot (5a) (Fig. H).

External dust extraction device

Attach a proper dust extraction device, e.g. a suitable vacuum cleaner attachment (\varnothing 35 mm) to the dust extraction outlet (41) (Fig. I).

Adjusting mitre angle (fig J, K)

1. Unlock the turntable locking handle (20) (Fig. J step 1).
2. Press the mitre angle adjustment lever (21) downward and hold it in position (Fig. J step 2).
3. Hold the turntable locking handle (20) and rotate the turntable (23) until the mitre angle pointer (16a) aligns with the desired angle on the mitre scale (16) (Fig. J step 3). Release the mitre angle adjustment lever (21).
4. Press down to lock the turntable locking handle (20) (Fig. J step 4).

There are default adjustment positions for the mitre angle at 0° , $\pm 15^\circ$, $\pm 22.5^\circ$, $\pm 31.6^\circ$ and $\pm 45^\circ$.

The mitre angle adjustment lever (21) can be locked at pressed position for convenience.

1. Press the mitre angle adjustment lever (21) downward and hold it in position (Fig.K step 1).

2. Push the miter angle adjustment lever locking knob (18) left to lock the lever (Fig.K step 2).
3. Press the miter angle adjustment lever (21) downward again to release the locking knob (18) (Fig. K step 3).

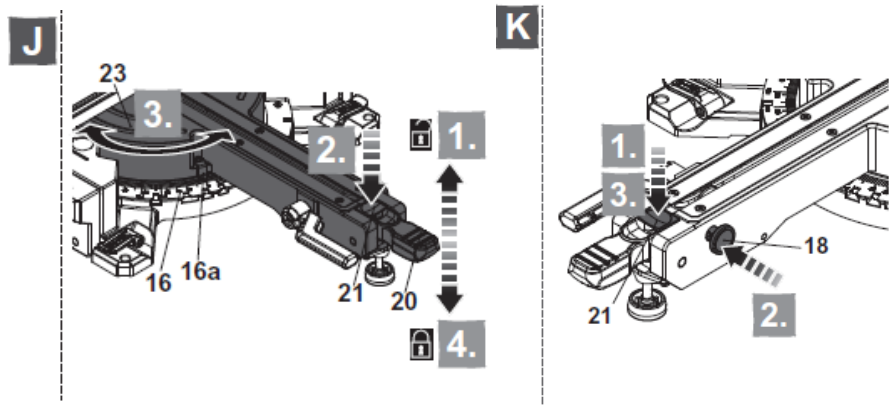

Adjusting mitre bevel (fig L)

1. Unlock the bevel angle locking lever (22) (Fig. L step 1).
2. Pull out the bevel angle locking knob (40) to enable the right bevel angle/ bevel angle > 45° if required (Fig. L step 2). Move the operating handle (1) a little before pulling out the bevel angle locking knob if necessary.
3. Move the operating handle (1) until the bevel angle pointer (10a) aligns with the desired angle on the bevel scale (10) (Fig. L step 3).

Always ensure the saw blade does not interfere with the fence or any other parts. Remove the fence if necessary.

4. Lock the bevel angle locking lever (Fig. L step 4).
- Always check the bevel locking handle (22) before working. A loose bevel locking handle may cause serious injury.

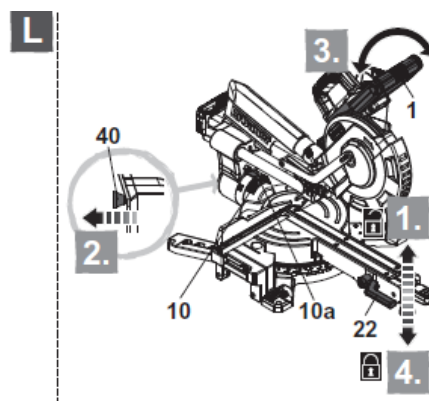

Adjusting mitre bevel (fig M)

Use the depth stop (35a) and adjustment knob (35c) to limit the cutting depth of the saw blade into the work piece.

1. Push in the depth stop (35a) to cut the work piece with the max. cutting depth.
2. Pull out the depth stop (35a) (step 1).
3. Loosen the locking nut (35b) (step 2).
4. Turn the adjustment knob (35c) clockwise to decrease the cutting depth (e. g. for non-through cutting operations such as grooving / slotting) (step 3).
5. Turn the adjustment knob (35c) anticlockwise to increase the cutting depth.

6. Tighten the locking nut (35b) (step 4).

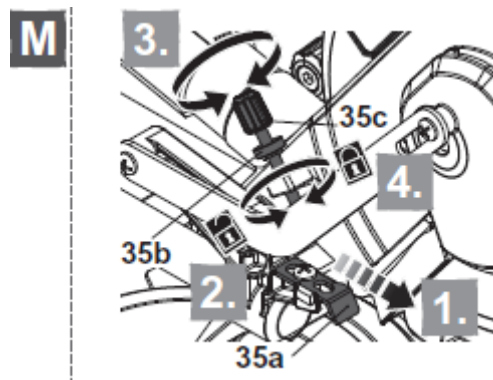

Adjusting slide cutting (fig N)

1. Use slide cutting to saw a work piece that is larger than the maximum cutting length of the saw blade.
2. Loosen the slide locking knob (8) (step 1) to allow the cutting head to slide freely (step 2).

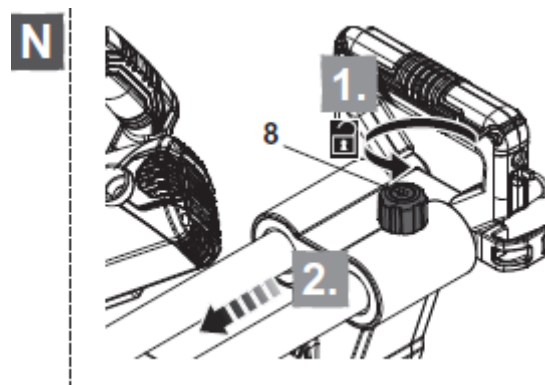

Adjusting extension supporter (fig O)

Use the extension supporter for supporting long work pieces. Use an additional support for extremely long work pieces if required.

1. Unlock the extension supporter locking lever (15) (step 1).
2. Pull out the extension supporter (14) to desired position (step 2).
3. Pull out the small fence (14a) if necessary (step 3).
4. Lock the extension supporter locking lever (15) (step 4).

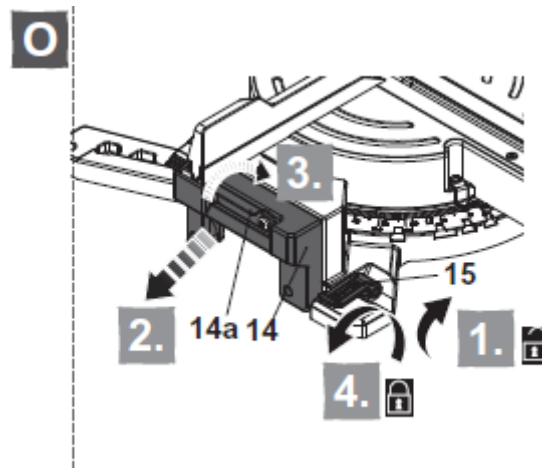

Adjusting fence (fig P)

1. Unlock the fence locking lever (37) (step 1).
2. Slide the fence (13) to desired position (step 2).
3. Lock the fence locking lever (37) (step 3).

Ensure the saw blade does not interfere with the fence by conducting a “dry run” with the cutting head set to the required bevel and miter angle.

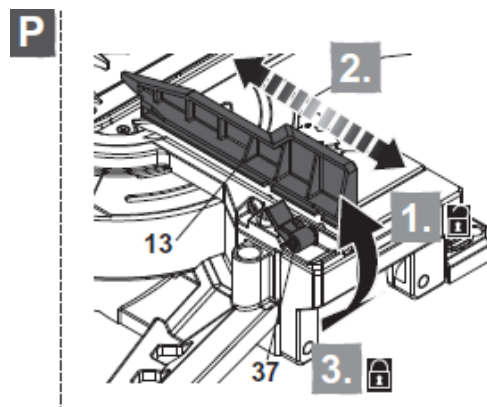

Adjusting work piece clamp (fig Q)

The work piece clamp (11) can be assembled on either side of the base. Use it to support work pieces of different thickness by adjusting the height of the bracket (11d) and plate (11c).

Ensure the motor housing does not interfere with the clamp while operation with the cutting head set to the required bevel and miter angle.

1. Loosen the locking knob (11a) (step 1) on the height adjustment pillar (11b) and adjust the bracket (11d) to the desired height (step 2). Tighten the locking knob to secure the bracket (step 3).
2. Press the locking button (11e) and hold it in position (step 4). Adjust the height of the plate (11c) to the surface of the work piece (step 5).
3. Rotate the height adjustment knob (11f) clockwise tightly to secure the work piece before operation (step 6).

Add a small scrap piece of thin plywood under the work piece clamp to avoid marking the work piece.

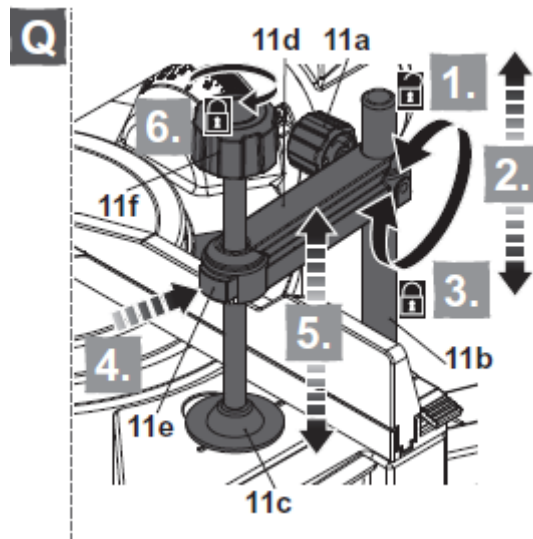

Switch on/off, Led Light and Laser (fig R,S)

1. Switch the LED light (25) on by pressing the “light” symbol of the LED light switch (2).
2. Switch the LED light off by pressing the “OFF” of the LED light switch.

Use the laser as guide when cutting.

3. Switch the laser (31) on by pressing the “laser” symbol of the laser switch (3).
4. Switch the laser off by pressing the “OFF” of the laser switch.

The laser line should be aligned with the blade cutting path. Readjustment of the laser shall always be carried out by the manufacturer of the tool or his service organization.

5. Press either the left safety lock button (29) or the right safety lock button (27) down to unlock the on/off switch (28) (step 1).
6. Press the on/off switch (28) to switch the product on (step 2).
7. Release the on / off switch (28) to switch the product off.

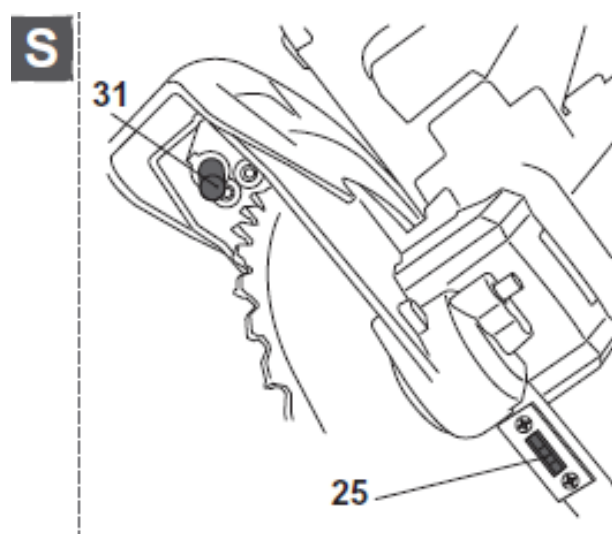
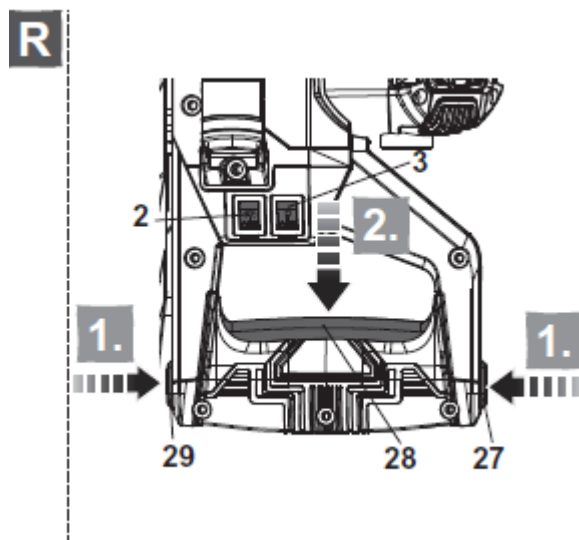

1.6 Technical data

Machines	CWM 216 240V	CWM 254 240V
Motor	1.4 kW 220V-240V With thermal overload protection	1.8 kW 220V-240V With thermal overload protection
Protection Class	II <input type="checkbox"/>	
Max. blade diameter	216 mm	254 mm
Bore size	30 mm	
Rotation speed of the blade	5000 min ⁻¹	4500 min ⁻¹
Cutting Capacity (bevel/mitre)	0° / 0°: 62 × 305 mm	0° / 0°: 90 × 305 mm
	0° / 45°(left/right): 62 × 215 mm	0° / 45°(left/right): 90 × 215 mm
	45°(left) / 0°: 30 × 305 mm	45°(left) / 0°: 40 × 305 mm
	45°(right) / 0°: 18 × 305 mm	45°(right) / 0°: 25 × 305 mm
	45°(left) / 45°(left/right): 30 × 215 mm	45°(left) / 45°(left/right): 40 × 215 mm
	45°(right) / 45°(left/right): 18 × 215 mm	45°(right) / 45°(left/right): 25 × 215 mm
Mitre capacity/ Bevel capacity	Left 48°-Right 48°/ Left 45°-Right 45°	Left 52°-Right 60°/ Left 45°-Right 45°
Sound pressure level Lpa	89 dB (A)	92 dB (A)
Sound power level Lwa	89 dB (A)	104 dB (A)
Uncertainly Kpa, Kwa	3 dB (A)	
Machines dimensions (L x l x H)	800x600x450mm	970x600x450mm
Weight with blade	16.81 kg	20.5 kg

1.7 Statement regarding noise emission

The sound emission values have been obtained according to the noise test code given in EN 62841-1 and EN 62841-3-9. The noise for the operator may exceed 80 dB(A) and ear protection measures are necessary.

1.8 Electrical connections

Check that:

- The voltage/phase supply corresponds to the information indicated on the machine.
- Available power supply must have ground connection in conformity with safety regulations.

1.9 Starting the machine

To start the machine:

Push the button on the right or left side of the handle with your thumb and press the switch on the inside of the handle

To stop the machine:

Release the buttons

2 TRANSPORT AND STORING

2.1 *Securing for transport*

Before transporting the machine, please follow the following instructions:

- Switch the product off and disconnect it from the power supply.
- Slide the cutting head fully forwards and tighten the slide locking knob (8) to avoid accidental sliding movement of the upper part.
- Follow the reverse order of “Assembly – Operation position” to set the product at locking position.
- Always carry the product by its base and transport handle. Never use the cord for carrying the product.
- Protect the product from any heavy impact or strong vibrations which may occur during transportation in vehicles.
- Secure the product to prevent it from slipping or falling over.

2.2 *Storing of the machine*

- Switch the product off and disconnect it from the power supply.
- Clean the product with a dry cloth. Use a brush for areas that are hard to reach.
- In particular, clean the switches and air vents after every use with a cloth and brush.
- Remove stubborn dirt with high pressure air (max. 3 bar).
- Check for worn or damaged parts. Replace worn parts as necessary or contact an authorised service centre for repair before using the product again.
- Slide the cutting head fully forwards and tighten the slide locking knob (8) if necessary.
- Follow the reverse order of “Assembly – Operation position” to set the product at locking position.
- Store the product and its accessories in a dark, dry, frost-free, well-ventilated place.
- Always store the product in a place that is inaccessible to children. The ideal storage temperature is between 10°C and 30°C.
- We recommend using the original package for storage or covering the product with a suitable cloth or enclosure to protect it against dust.

3 OPERATING THE MACHINE

3.1 *Installation*

3.1.1 Information concerning the working site

- Remove from the site anything, which might hinder the working procedure.
- Make sure the site is sufficiently well lit.
- Observe manufacturer's conditions for connecting to power supplies.
- Place electric cables in such a way that damage is excluded.
- Make sure you have a continual adequate view of the working area so you can intervene in the working process at any time.
- Keep other staff out of the area, so you can work safely.
- Set the machine on the flat and stable ground.

3.1.2 Space required for operation and maintenance

In order to use and maintain the machine safely and correctly, leave 2 m in front and 1, 5 m around of the machine.

3.2 *Maintenance*

Your power tool requires no additional lubrication or maintenance.

There are no user serviceable parts in your power tool.

Before and after each use, check the product and accessories (or attachments) for wear and damage. If required, exchange them for new ones as described in this instruction manual. Observe the technical requirements.

If the replacement of the supply cord is necessary, this has to be done by the manufacturer or his agent in order to avoid a safety hazard.

4 BREAKDOWN – CAUSES AND CURES

4.1 Breakdown-finding procedures

Should any breakdown occur during the use of the machine, turn it off, and isolate it from the electrical supply. Any works dealing with the electrical system or supply of the machine can only be carried out by a qualified electrician.

4.2 Trouble-shooting guide

Trouble	Possible source	Resolution
1.Product does not start	1.1. Not connected to power supply 1.2. Power cord or plug is defective 1.3. Other electrical defect to the product	1.1. Connect to power supply 1.2. Check by a specialist electrician 1.3. Check by a specialist electrician
2.Product does not reach full power	2.1. Extension cord not suitable for operation with this product 2.2. Power source (e.g. generator) has too low Voltage 2.3. Air vents are blocked	2.1. Use a proper extension cord 2.2. Connect to another power Source 2.3. Clean the air vents
3. Product does not cut	3.1. Not connected to power supply 3.2. Saw blade is worn or damaged 3.3. Bevel and mitre angle incorrectly adjusted	3.1. Connect to power supply 3.2. Replace with new one 3.3. Check and adjust according to the instruction manual
4.Unsatisfactory result	4.1. Dull / damaged saw blade 4.2. Cutting angle is incorrect 4.3. Saw blade not suitable for work piece material 4.4. Overheated saw blade 4.5. Workpiece not clamped / placed properly	4.1. Replace with new one 4.2. Adjust the bevel and / or mitre cutting angle 4.3. Use proper saw blade 4.4. Let the work cool down before using again 4.5. Clamp / place the workpiece properly before cutting
5. Excessive vibration or noise	5.1. Saw blade is dull/ damaged 5.2. Bolts/nuts are loose	5.1. Replace with a new one 5.2. Tighten bolts/nuts

4.3 *Customer service*

When ordering spare parts, please mention:

- The serial number (7 digits).
- The code of the part.
- The exact denomination.
- The number of parts required.
- The delivery address.
- Please indicate clearly the means of transportation required such as "express" or "by air". Without specific instructions, we will forward the parts through the means which seem appropriate to us --- but which is not always the quickest way.

Clear instructions will avoid problems and faulty deliveries.

If not sure, please send us the defective part.

In the case of a warranty claim, the part must always be returned for evaluation.

Spare parts for the motor can be ordered with the manufacturer of the motor or with their dealer, which is often quicker and cheaper.

This machine has been manufactured by: Saint-Gobain Abrasives S.A.

190, Bd. J. F. Kennedy
L- 4930 BASCHARAGE
Grand-duché de Luxembourg.

Tel.: 00352-50 401-1

Fax: 00352- 50 16 33

<http://www.construction.norton.eu>

e-mail: sales.nlx@saint-gobain.com

4.4 Spare parts

In order to consult the spare parts lists, we invite you to visit the after-sales website of Norton Clipper by using the following address:

<https://spareparts.nortonabrasives.com>

For a quick access, you can also use the QR Code shown below using your mobile phone:



This electronic catalogue provides exploded views and spare parts lists for different machines designed by Norton Clipper so you can find references you need.

4.5 Recycling and disposal

Waste electrical products should not be disposed of with household waste. Please recycle where facilities exist. Check with your local authority or local store for recycling advice.

SAINT-GOBAIN ABRASIVES
INDUSTRIEWEG 21
9420 ERPE-MERE
BELGIUM
TEL: +32(0) 2 267 21 00

SAINT-GOBAIN CONSTRUCTION PRODUCTS
CZ A.S.
DIVIZE ABRASIVES
SMRČKOVA 2485/4
180 00 PRAHA 8
CZECH REPUBLIC
TEL: +420 255 719 326
FAX: +420 255 719 321

SAINT-GOBAIN ABRASIVES A/S
DYBENDALSVEENGET 2,
DK-2630 TAASTRUP
DENMARK
TEL: +45 4675 5244

PO BOX 643706
FORTUNE TOWER OFFICE 2106
JLT BLOCK C
(NEXT TO METRO STATION)
JUMEIRA LAKE TOWER, DUBAI
UNITED ARAB EMIRATES
TEL: +971 4 431 5154
FAX: +971 4 431 5434

SAINT-GOBAIN ABRASIFS
RUE DE L'AMBASSADEUR - B.P.8
78 702 CONFLANS CEDEX
FRANCE
TEL: +33 (0)1 34 90 40 00
FAX: +33 (0)1 39 19 89 56

SAINT-GOBAIN ABRASIVES GMBH
BIRKENSTRASSE 45-49
D-50389 WESSELING
GERMANY
TEL: +49 (0) 2236 703-0
FAX: +49 (0) 2236 703-730

SAINT-GOBAIN ABRASIVES KFT.
1225 BUDAPEST
BÁNYALÉG U. 60/B.
HUNGARY
TEL: +36 1 371 22 50
FAX: +36 1 371 22 55

SAINT-GOBAIN ABRASIVI S.P.A
VIA PER CESANO BOSCONI 4
I-20094 CORSICO MILANO
ITALY
TEL: +39 02 44 851
FAX: +39 02 44 78 266

SAINT-GOBAIN ABRASIVES S.A.
190 RUE J.F. KENNEDY
L-4930 BASCHARAGE
GRAND DUCHE DE LUXEMBOURG
TEL: +352 50 401 1
FAX: +331 83 717 792
NO. VERT (FRANCE): 0800 906 903

SAINT-GOBAIN ABRASIFS, S.A.
2 ALLÉE DES FIGUIERS
AIN SEBAÄ - CASABLANCA
MOROCCO
TEL: +212 5 22 66 57 31
FAX: +212 5 22 35 09 65

SAINT-GOBAIN ABRASIVES BV
GROENLOSEWEG 28
7151 HW EIBERGEN
P.O. BOX 10
7150 AA EIBERGEN
THE NETHERLANDS
TEL: +31 545 466466
FAX: +31 545 474605

SAINT-GOBAIN ABRASIVES AS
KARIHAUGVEIEN, 89
0186 OSLO
NORWAY
TEL: +47 63 87 06 00
FAX: +47 63 87 06 01

SAINT-GOBAIN HPM POLSKA SP. Z O.O.
UL. NORTON 1, 62-600 KOŁO
62-600 KOŁO
POLAND
TEL: +48 63 26 17 100
FAX: +48 63 27 20 401

SAINT-GOBAIN ABRASIVOS, L. DA
ZONA INDUSTRIAL DA MAIA
I-SECTOR VIII, NO. 122
APARTADO 6050
4476 - 908 MAIA
PORTUGAL
TEL: +351 229 437 940
FAX: +351 229 437 949

SAINT-GOBAIN GLASS
BUSINESS UNIT ABRASIVI
PUNCT DE LUCRU : LOC.VETIS, JUD.
SATU MARE 447355
STR. CAREIULUI 11
PARC INDUSTRIAL RENOVATIO
ROMANIA
TEL: +40 261 839 709
FAX: +40 261 839 710

SG HPM RUS
58, F. ENGELS STR.
STROENIE 2
105082 MOSCOW
RUSSIA
TEL: +74 955 408 355
FAX: +74 959 373 224

SAINT-GOBAIN
ABRASIVES (PTY) LTD
2 MONTEER ROAD
ISANDO 1600
P.O. BOX 67
SOUTH AFRICA
TEL: +27 11 961 2000
FAX: +27 11 961 2184/5

SAINT-GOBAIN ABRASIVOS, S.A.
CTRA. DE GUIPÚZCOA, KM. 7,5
E-31195 BERRIOPLANO (NAVARRA)
SPAIN
TEL: +34 948 306 000
FAX: +34 948 306 042

SAINT GOBAIN ABRASIVES AB
GÅRDSFOGDEVÄGEN 18A
168 66 BROMMA • SVERIGE
SWEDEN
TEL: +46 8 580 881 00
FAX: +46 8 580 881 30

SAINT-GOBAIN INOVATIF MALZEMELER VE
ASINDIRICI SAN. TIC. AS.
ALTAYÇEŞME MAH. ÇAMLI SOK. NO:21 ESAS
OFISPAK KAT:9 34843
MALTEPE, İSTANBUL • TURKEY
TEL: 0090-216-217 12 50
FAX: 0090-216-442 40 74

SAINT-GOBAIN ABRASIVES LTD.
UNICORN HOUSE UNIT 1, AMISON CLOSE
REDHILL BUSINESS PARK
STAFFORD ST161WB
UNITED KINGDOM
TEL: +44 1785 279 553
FAX: +44 1785 213 487



Saint-Gobain Abrasifs
190 Rue J.F. Kennedy
L-4930 Bascharage
Grand Duche de Luxembourg
Tel: +352 50 4011
Fax: +331 83 717 792
no. vert (France) 0800 906 903

www.nortonabrasives.com/fr-fr



Saint-Gobain Abrasifs
190 Rue J.F. Kennedy
L-4930 Bascharage
Grand Duche de Luxembourg
Tel: +331 83 717 792
Fax: +352 50 16 33
no. vert (France) 0800 906 903

www.nortonabrasives.com/fr-fr