

Speedy Cart™

OPERATING INSTRUCTIONS

Translation of the original instructions



SAINT-GOBAIN

clipper®

Speedy Cart TM: OPERATING INSTRUCTIONS

1	<u>BASIC SAFETY INSTRUCTIONS</u>	4
1.1	<i>Pictogrammes</i>	4
1.2	<i>Machine plate</i>	5
1.3	<i>Safety instructions for particular operating phases</i>	5
2	<u>GENERAL DESCRIPTION</u>	6
2.1	<i>Short description</i>	6
3	<u>ASSEMBLY AND COMMISSIONING</u>	7
4	<u>OPERATING THE TROLLEY</u>	10
4.1	<i>Site of work</i>	10
4.2	<i>Cutting method</i>	10
5	<u>TRANSPORT AND STORING</u>	11
5.1	<i>Securing for transport</i>	11
5.2	<i>Transport procedure</i>	11
5.3	<i>Customer service</i>	12
5.4	<i>Spare parts</i>	13

1 BASIC SAFETY INSTRUCTIONS

The Trolley (Speedy cart) is exclusively designed for the cutting of floors made of asphalt, green and cured concrete (reinforced or not) as well as of industrial cement.

Uses other than the manufacturer's instructions shall be considered as contravening the regulations. The manufacturer shall not be held responsible for any resulting damage. Any risk shall be borne entirely by the user. Observing the operating instructions and compliance with inspection and servicing requirements shall also be considered as included under use in accordance with the regulations.

1.1 Pictogrammes

Important warnings and pieces of advice are indicated on the machine using symbols. The following symbols are used on the machine :



Read operator's instructions



Hand protection must be worn



Ear protection must be worn



Eye protection must be worn



Never touch the tool during operation



For dry cutting, dust mask must be worn

1.2 *Machine plate*

Important data can be found on the following plate located on the machine:

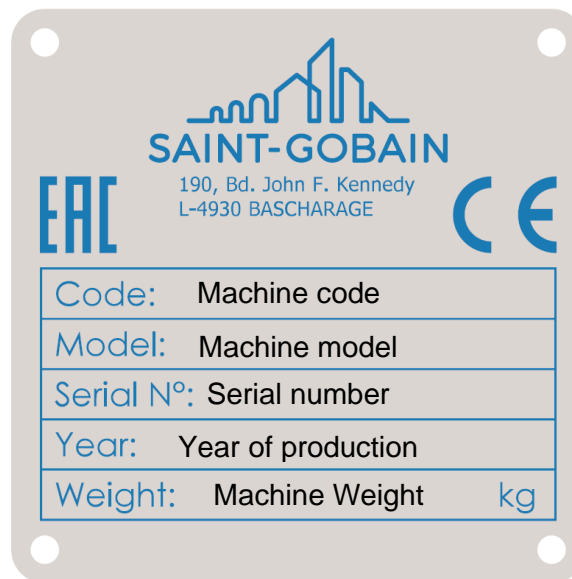

1.3 *Safety instructions for particular operating phases*

Before commencing work

- Before commencing work, make yourself familiar with the working environment at the place of use. The working environment includes: obstacles in the area of work and manoeuvre, the firmness of the floor, necessary protection at the site relating to public thoroughfares and the availability of help in the event of accidents.
- Check for correct mounting of the blade regularly.
- Immediately remove damaged or badly worn blades, as they endanger the operator whilst rotating.
- Only fit NORTON diamond blades to the machine! The use of other tools can damage the machine!
- Read the blades' specifications carefully to choose the correct tool for your application.
- Attention is drawn to the use of BS2092 safety goggles in conformity with specified Processes No.8 of the Protection of Eyes Regulation 1974, Regulation 2(2) Part 1. Also use the other safety equipment as mentioned in the symbols plus a dust mask when dry cutting is applied.
- For security reasons, never leave the machine unattended, untied or unlocked.

2 GENERAL DESCRIPTION

Any modification, which could lead to a change in the original characteristics of the machine, may be done only by Saint-Gobain Abrasives S.A. who shall confirm that the machine is still in conformity with the safety regulations. Saint-Gobain Abrasives S.A. keeps the right of making technical or design modification without prior notification.

2.1 Short description

The Trolley you have chosen is used for small repair works in concrete and asphalt, for cutting induction loops and installing cables as well as for cutting expansion joints. It can be used for either wet or dry cutting operations.

Being of small construction, it can be transported in a car or van; the handle can be removed, reversed or retracted.

All component parts on the trolley are assembled to a high quality standard, ensuring long life, reliability and a minimum of maintenance.

Special types of blades are available for asphalt, green concrete, cured concrete (reinforced or not) as well as for industrial cement flooring.



3 ASSEMBLY AND COMMISSIONING

- In order to mount the saw on the cart, find the index plunger (1) on the saw support and pull it to unlock the part (2).

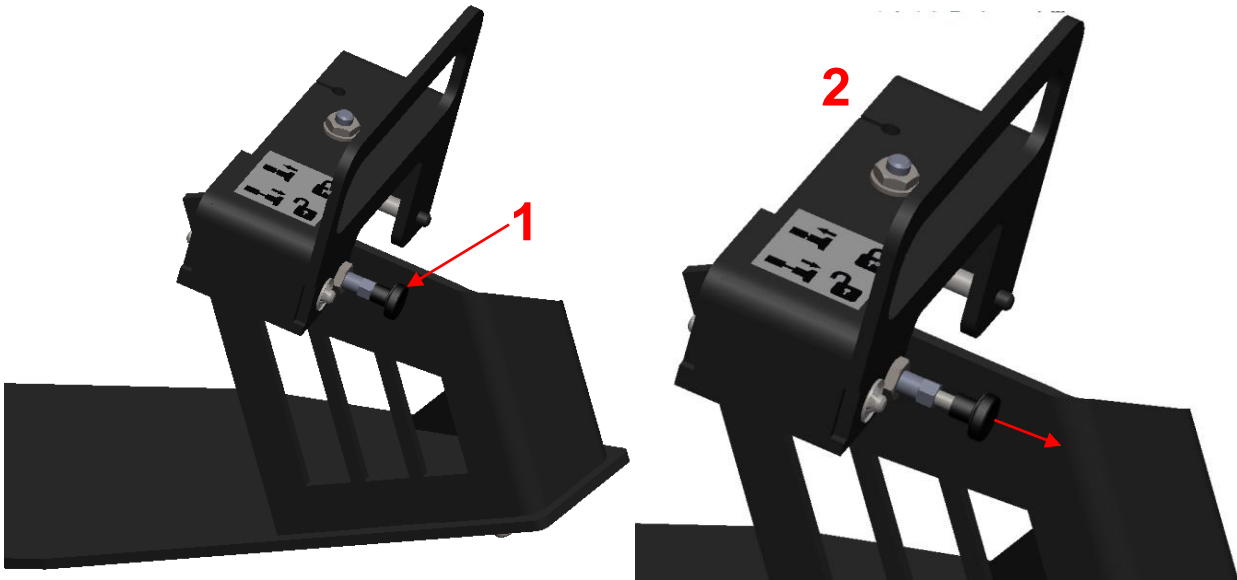

- While pulling the button, pivot the part (2) thanks to the handle (3).

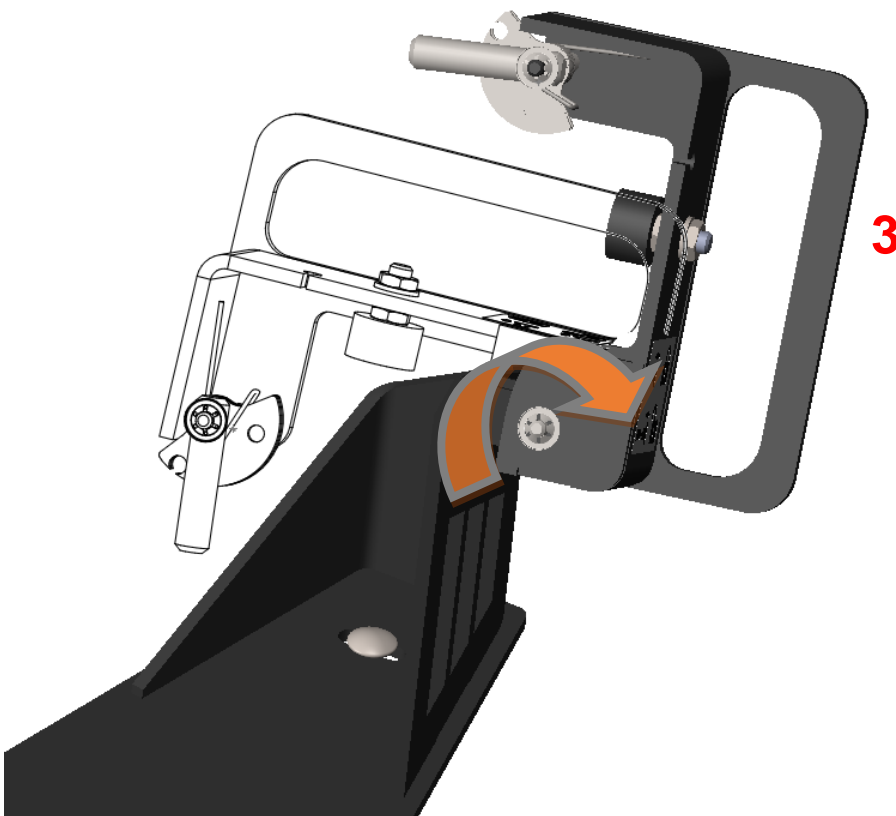

- Your Speedy Cart [™] is now ready to welcome the saw.



- Insert the saw on its support taking care that the 2 feet are totally engaged in the front part (4) of the support.
- Insert then the handle of the saw in the back of the support (5).



- Drop the part (6) until you hear the « click » corresponding to the engagement of the index plunger. Check this one is in locked position to finish the installation and to start utilization.

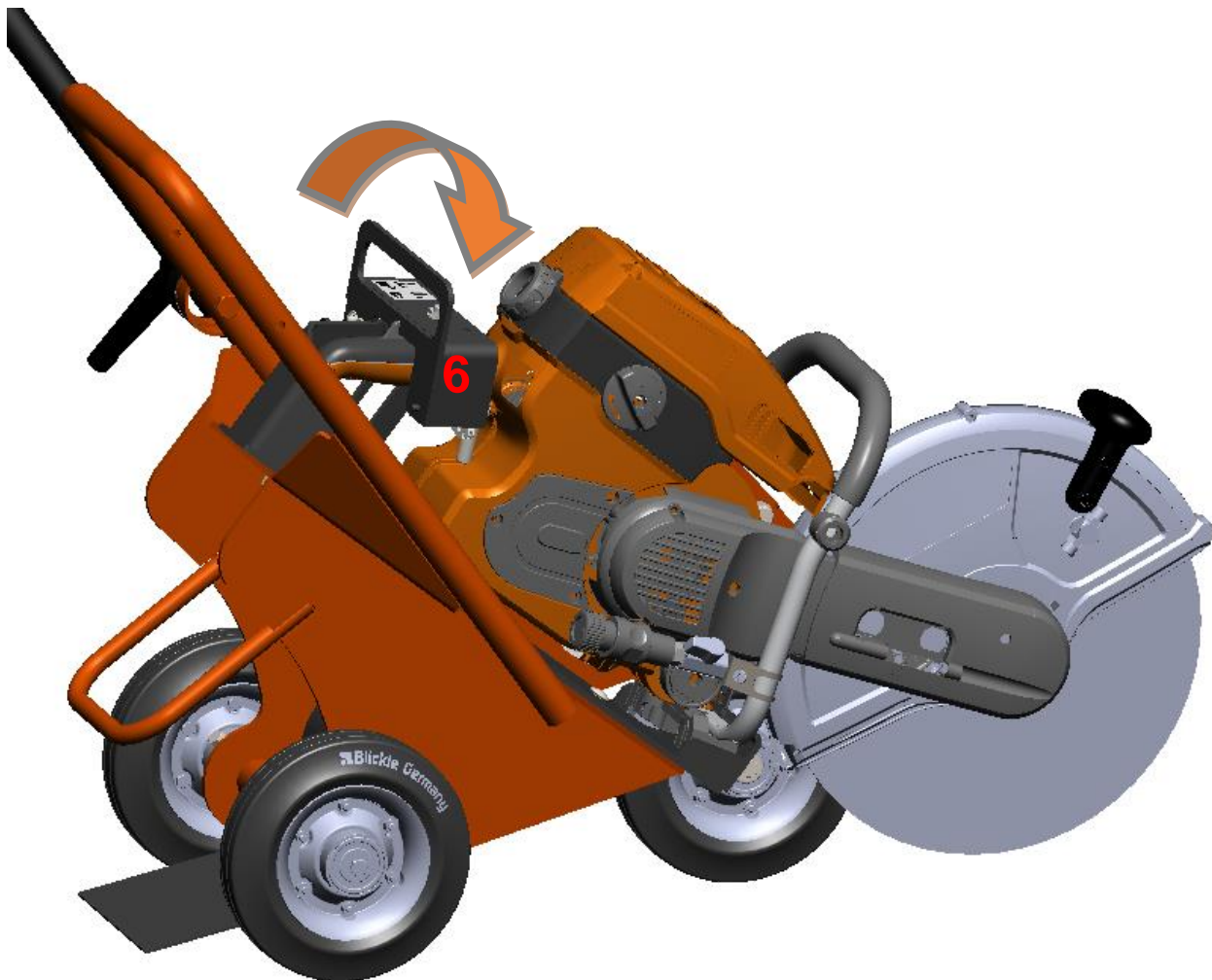

4 OPERATING THE TROLLEY

4.1 Site of work

Before you start working, please check the following points:

- Remove from the site anything, which might hinder the working procedure.
- Make sure the site is sufficiently well lit.
- Make sure you have a continual adequate view of the working area so you can intervene in the working process at any time.
- Keep other staff out of the area, so you can work securely.

4.2 Cutting method

In this section, you can find instructions to make a straight cut at the desired depth.

4.2.1 Preparing your cut

Before starting the machine,

- Draw a line on the floor over the cutting length.
- Make sure you have filled the engine tank with fuel.
- Make sure you have mounted the correct blade as recommended by the manufacturer depending on the material to be worked, the working procedure (dry or wet cut) to be carried out, and the efficiency required.
- Make sure that the flanges securely hold the diamond blade.
- Make sure that the blade is not touching the floor before starting.
- Bring the handle in a comfortable position.
- Roll the machine until the blade is over the line.

4.2.2 Cutting the floor

You can now start the engine.

To make your cut,

- In order to reach the wished cutting depth, place your foot on the foot rest (1) and pull the depth locking lever (2) toward you. Be careful, the machine can now dive freely. Hold the handlebar firmly.

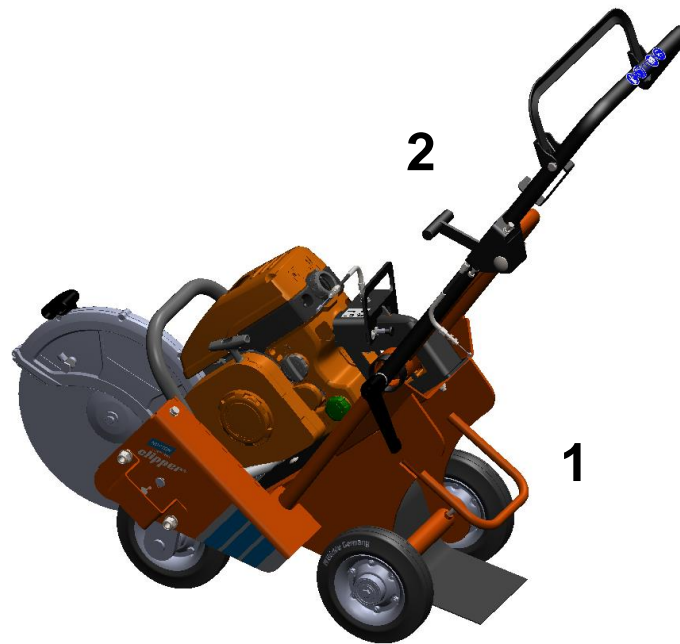

- While accelerating at full speed, get low until the wished depth is reached.
- Once the depth is reached, switch the lever forward.
- Push the machine forward with steady and gentle pressure and follow the line.
- At the finish of the cut, raise the blade out of the cut, shut-off the water and switch off the engine.

5 TRANSPORT AND STORING

Take the following measures in order to transport and store the Trolley securely.

5.1 *Securing for transport*

Before transporting the machine :

- Remove the blade.
- Raise the cutting head to its highest position using the lever.

5.2 *Transport procedure*

The machine can be moved on a flat surface using its wheels. Do not lift this machine using a crane as no part of the machine is designed to hold up the Trolley's weight.

5.3 Customer service

When ordering spare parts, please mention:

- The serial number (7 digits).
- The code of the part.
- The exact denomination.
- The number of parts required.
- The delivery address.
- Please indicate clearly the means of transportation required such as "express" or "by air". Without specific instructions, we will forward the parts through the means which seem appropriate to us --- but which is not always the quickest way.

Clear instructions will avoid problems and faulty deliveries.

If not sure, please send us the defective part.

In the case of a warranty claim, the part must always be returned for evaluation.

Spare parts for the motor can be ordered with the manufacturer of the motor or with their dealer, which is often quicker and cheaper.

This machine has been manufactured by: Saint-Gobain Abrasives S.A.

190, Bd. J. F. Kennedy

L- 4930 BASCHARAGE

Grand-duché de Luxembourg.

Tel.: 00352-50 401-1

Fax: 00352- 50 16 33

<http://www.construction.norton.eu>

e-mail: sales.nlx@saint-gobain.com

5.4 Spare parts

In order to consult the spare parts lists, we invite you to visit the after-sales website of Norton Clipper by using the following address:

<https://spareparts.nortonabrasives.com>

For a quick access, you can also use the QR Code shown below using your mobile phone:



This electronic catalogue provides exploded views and spare parts lists for different machines designed by Norton Clipper so you can find references you need.

Guarantee can be claimed and technical support obtained from your local distributor where machines, spare parts and consumables can be ordered as well:

SAINT-GOBAIN ABRASIVES
INDUSTRIEWEG 21
9420 ERPE-MERE
BELGIUM
TEL: +32(0) 2 267 21 00

SAINT-GOBAIN CONSTRUCTION
PRODUCTS CZ A.S
DIVIZE ABRASIVES
SMRČKOVA 2485/4
180 00 PRAHA 8
CZECH REPUBLIC
TEL: +420 255 719 326
FAX: +420 255 719 321

SAINT-GOBAIN ABRASIVES A/S
DYBENDALSVEJENGET 2,
DK-2630 TAASTRUP
DENMARK
TEL: +45 4675 5244

PO BOX 643706
FORTUNE TOWER OFFICE 2106
JLT BLOCK C
(NEXT TO METRO STATION)
JUMEIRA LAKE TOWER, DUBAI
UNITED ARAB EMIRATES
TEL: +971 4 431 5154
FAX: +971 4 431 5434

SAINT-GOBAIN ABRASIFS
RUE DE L'AMBASSADEUR - B.P.8
78 702 CONFLANS CEDEX
FRANCE
TEL: +33 (0)1 34 90 40 00
FAX: +33 (0)1 39 19 89 56

SAINT-GOBAIN ABRASIVES GMBH
BIRKENSTRASSE 45-49
D-50389 WESSELING
GERMANY
TEL: +49 (0) 2236 703-0
FAX: +49 (0) 2236 703-730

SAINT-GOBAIN ABRASIVES KFT.
1225 BUDAPEST
BÁNYALÉG U. 60/B.
HUNGARY
TEL: +36 1 371 22 50
FAX: +36 1 371 22 55

SAINT-GOBAIN ABRASIVI S.P.A
VIA PER CESANO BOSCONI 4
I-20094 CORSICO MILANO
ITALY
TEL: +39 02 44 851
FAX: +39 02 44 78 266

SAINT-GOBAIN ABRASIVES S.A.
190 RUE J.F. KENNEDY
L-4930 BASCHARAGE
GRAND DUCHE DE LUXEMBOURG
TEL: +352 50 401 1
FAX: +331 83 717 792
NO. VERT (FRANCE): 0800 906 903

SAINT-GOBAIN ABRASIFS, S.A.
2 ALLÉE DES FIGUIERS
AIN SEBAË - CASABLANCA
MOROCCO
TEL: +212 5 22 66 57 31
FAX: +212 5 22 35 09 65

SAINT-GOBAIN ABRASIVES BV
GROENLOSEWEG 28
7151 HW EIBERGEN
P.O. BOX 10
7150 AA EIBERGEN
THE NETHERLANDS
TEL: +31 545 466466
FAX: +31 545 474605

SAINT-GOBAIN ABRASIVES AS
KARIHAUGVEIEN, 89
0186 OSLO
NORWAY
TEL: +47 63 87 06 00
FAX: +47 63 87 06 01

SAINT-GOBAIN HPM POLSKA SP. Z O.O.
UL. NORTON 1, 62-600 KOŁO
62-600 KOŁO
POLAND
TEL: +48 63 26 17 100
FAX: +48 63 27 20 401

SAINT-GOBAIN ABRASIVOS, L. DA
ZONA INDUSTRIAL DA MAIA
I-SECTOR VIII, NO. 122
APARTADO 6050
4476 - 908 MAIA
PORTUGAL
TEL: +351 229 437 940
FAX: +351 229 437 949

SAINT-GOBAIN GLASS
BUSINESS UNIT ABRASIVI
PUNCT DE LUCRU : LOC.VETIS, JUD.
SATU MARE 447355
STR. CAREIULUI 11
PARC INDUSTRIAL RENOVATIO
ROMANIA
TEL: +40 261 839 709
FAX: +40 261 839 710

SG HPM RUS
58, F. ENGELS STR.
STROENIE 2
105082 MOSCOW
RUSSIA
TEL: +74 955 408 355
FAX: +74 959 373 224

SAINT-GOBAIN
ABRASIVES (PTY) LTD
2 MONTEER ROAD
ISANDO 1600
P.O. BOX 67
SOUTH AFRICA
TEL: +27 11 961 2000
FAX: +27 11 961 2184/5

SAINT-GOBAIN ABRASIVOS, S.A.
CTRA. DE GUIPÚZCOA, KM. 7,5
E-31195 BERRIOPLANO (NAVARRA)
SPAIN
TEL: +34 948 306 000
FAX: +34 948 306 042

SAINT GOBAIN ABRASIVES AB
GÅRDSFOGDEVÄGEN 18A
168 66 BROMMA • SVERIGE
SWEDEN
TEL: +46 8 580 881 00
FAX: +46 8 580 881 30

SAINT-GOBAIN INOVATIF MALZEMELER
VE ASINDIRICI SAN. TIC. AS.
ALTAYÇEŞME MAH. ÇAMLI SOK. NO:21
ESAS OFİSPARK KAT:9 34843
MALTEPE, İSTANBUL • TURKEY
TEL: 0090-216-217 12 50
FAX: 0090-216-442 40 74

SAINT-GOBAIN ABRASIVES LTD.
UNICORN HOUSE UNIT 1, AMISON CLOSE
REDHILL BUSINESS PARK
STAFFORD ST161WB
UNITED KINGDOM
TEL: +44 1785 279 553
FAX: +44 1785 213 487



Saint-Gobain Abrasifs
190 Rue J.F. Kennedy
L-4930 Bascharage
Grand Duché de Luxembourg
Tel: +352 50 4011
Fax: +331 83 717 792
no. vert (France) 0800 906 903

www.nortonabrasives.com/fr-fr