

CWM 254

SPARE PART LIST

LISTE DE PIÈCES DE RECHANGE

ERSATZTEILLISTE

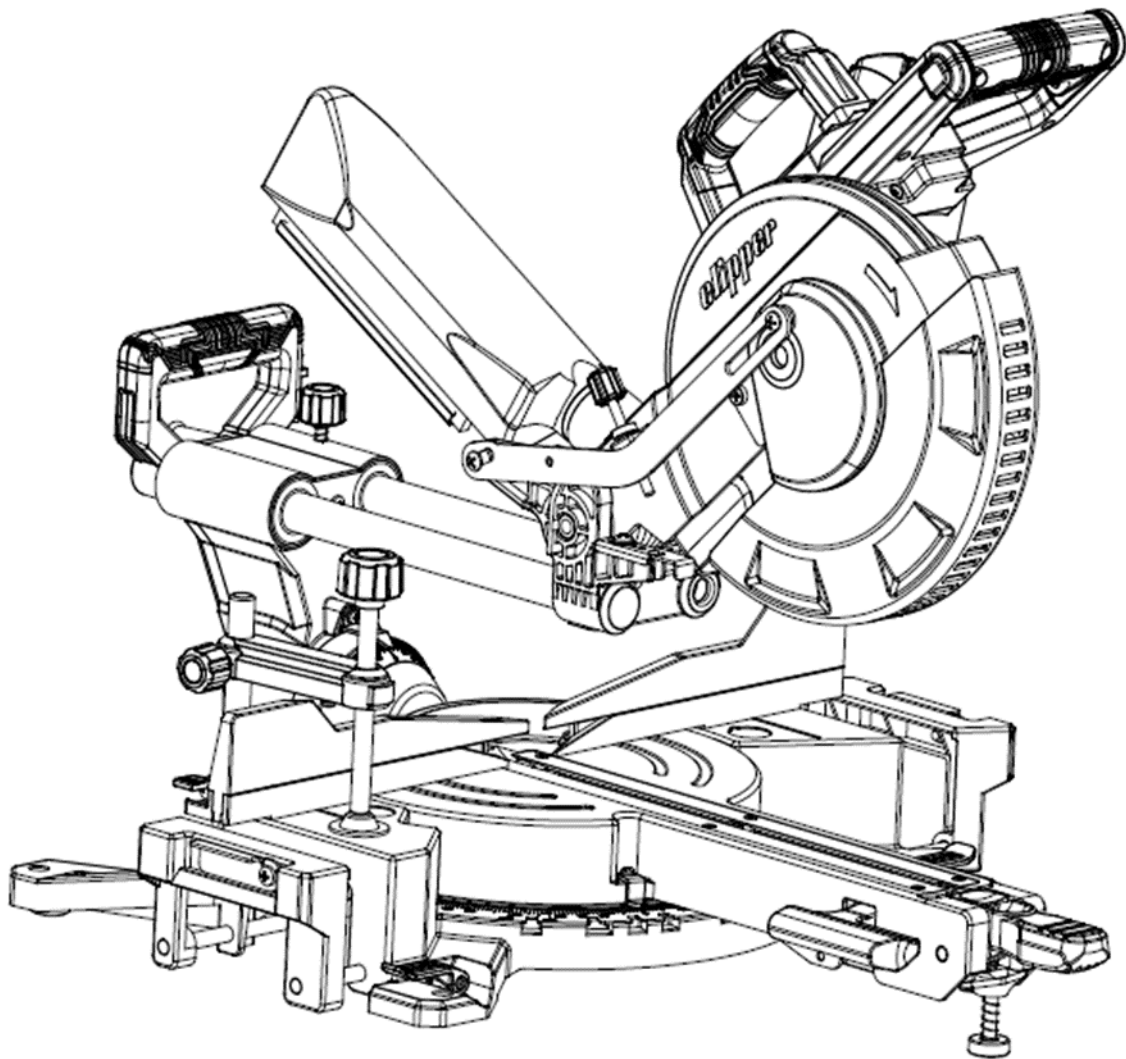

NORTON
SAINT-GOBAIN®

clipper®



TM

ENGLISH

TYPE:

S = Spare part

W = Wear part

NA = Not Available

The kits of spare parts contain all screws and bolts and the components referring itself to it.

Screws and bolts is component of standard assembly, which you can easily find at all the retailers of standard components of assembly.

All the components of standard assembly are of a quality grade 8.8.

We recommend not to use a quality grade lower than 8.8 for all the standard components of assembly.

The parts of replacements Norton CLIPPER must always be used.

Wear parts life will vary based on usage and maintenance of the machine or part. Wear parts will need to be maintained and replaced as needed. No warranty is applied to wear parts.

The components NA (Not Available) are not available in spare part.

FRANCAIS

TYPE :

S = Pièce de rechange

W = Pièce d'usure

NA = Non disponible

Les kits de pièces détachées contiennent toute la visserie et les composants s'y rapportant.

La visserie est un composant d'assemblage standard, que vous pouvez facilement trouver chez tous les détaillants de composants d'assemblage standards.

Tous les composants d'assemblage standard sont d'une classe de qualité 8.8.

Nous recommandons de ne pas utiliser une classe de qualité inférieure à 8.8 pour tous les composants d'assemblage standards.

Pour les pièces non standard, les pièces de remplacement doivent impérativement provenir de Norton CLIPPER.

La durée de vie des pièces d'usure varie en fonction de l'utilisation et de la maintenance de la machine ou de la pièce. Les pièces d'usure devront être entretenues et remplacées au besoin. Aucune garantie n'est appliquée aux pièces d'usure.

Les composants NA (Not Available) ne sont pas disponibles en pièce de rechange.

DEUTSCH

TYP :

S = Ersatzteile

W = Verschleißteile

NA = nicht verfügbare

Die definierten Ersatzteil-Set's beinhalten alle Ersatzteile wie Komponenten, Schrauben, Muttern etc.

Norm- bzw. Standardteile wie Schrauben, Muttern etc. können bei offiziellen Schrauben- sowie Komponentenhändler bezogen werden.

Alle Norm- bzw. Standardteile wie Schrauben, Muttern etc. entsprechen der Qualitäts- bzw. Festigungsklasse 8.8.

Wir empfehlen, keine Norm- bzw. Standardteile wie Schrauben, Muttern etc. unter der Qualitäts- bzw.

Festigungsklasse 8.8 einzusetzen.

Es dürfen nur geprüfte Norton CLIPPER-Ersatzteile eingesetzt werden.

Die Lebensdauer der Verschleißteile hängt von der Verwendung und Wartung der Maschine oder des Teils ab. Verschleißteile müssen gewartet und bei Bedarf ersetzt werden. Für Verschleißteile wird keine Garantie übernommen.

Ersatzteile sowie Komponenten mit dem Vermerk NA (NA=nicht verfügbar) sind nicht verfügbar.

Table / Table / Rahmen

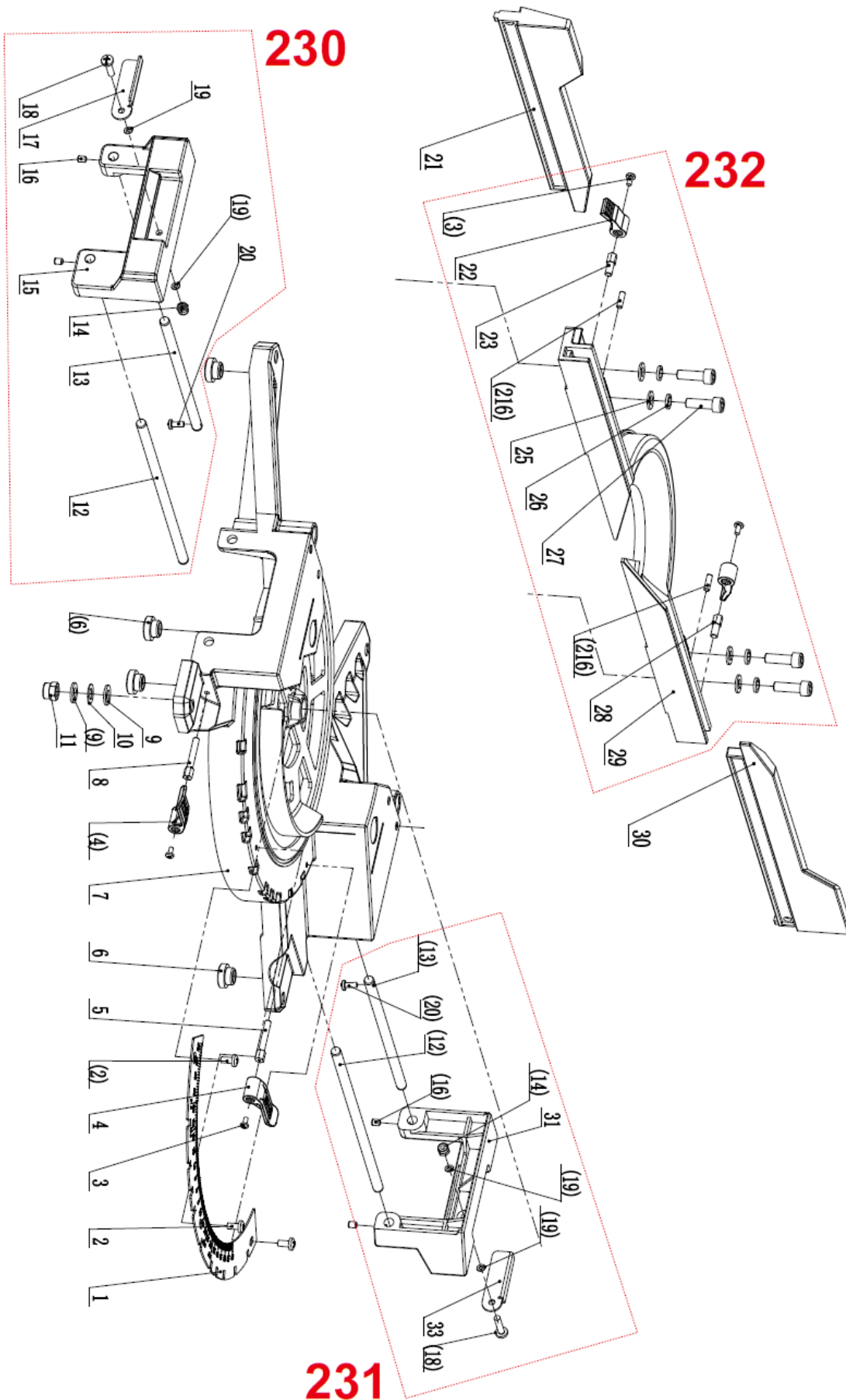

POS.	DESCRIPTION	DESCRIPTION	BESCHREIBUNG	QTY	REF
1	Miter Angle Scale	Mitre échelle Angle	Gehrungswinkelskala	1	310543979
2	Socket Head Button Screw M5x12	Vis à tête Bouton Vis M5x12	Innensechskantschraube M5 x 12	1	NA
4	Lock Handle	Poignée de verrouillage	Griff verriegeln	1	310543982
5	Lock Bolt (RH Threads)	Boulon de verrouillage (RH Threads)	Verriegelungsbolzen (rechte Gewinde)	1	310543983
6	Foot	Pied	Fuß	1	310543980
7	Base	Base	Base	1	310543981
8	Lock Bolt (LH Threads)	Boulon de verrouillage (LH Threads)	Verriegelungsbolzen (linke Gewinde)	1	310543984
9	Flat Washer Diam.10	rondelle plate Diam.10	Unterlegscheibe Diam.10	1	NA
10	Wave Washer Diam.10	Rondelle Ondulée Diam.10	Wellenscheibe Diam.10	1	NA
11	Hex Nut, Nylon Lock M10	Écrou hexagonal, Nylon verrouillage M10	Sechskantmutter, Nylonschloss M10	1	310543985
21	Fence Extension, Left	Extension Clôture, Gauche	Zaunverlängerung, links	1	310544006
24	Socket Set Screw M6x16	Jeu de douilles à vis M6x16	Innensechskantschraube M6 x 16	1	NA
30	Fence Extension, Right	Extension de clôture, droit	Zaunverlängerung, rechts	1	310544007
32	Spring Diam.1	Ressort Diam.1	Federdurchmesser 1	1	310544008
230	Left Worktable set	Extension de table gauche	Linker Arbeitstisch eingestellt		310544605
12	Extension Rod (Long)	Rod Extension (longue)	Verlängerungsstange (lang)	1	NA
13	Extension Rod (Short)	Rod Extension (Short)	Verlängerungsstange (kurz)	1	NA
14	Hex Nut, Nylon Lock	Écrou hexagonal, Nylon verrouillage	Sechskantmutter, Nylonschloss	1	NA
15	Left Worktable	gauche Worktable	Linker Arbeitstisch	1	NA
16	Socket Set Screw	Jeu de douilles à vis	Innensechskantschraube	2	NA
17	Left Stop Plate	Plaque gauche Arrêt	Linke Stopplatte	1	NA
18	Pan Head Machine Screw	Vis à tête cylindrique	Pan Head Maschinenschraube	1	NA
19	Flat Washer	rondelle plate	Unterlegscheibe	2	NA
20	Pan Head Machine Screw	Vis à tête cylindrique	Pan Head Maschinenschraube	1	NA
231	Right Worktable set	Extension de table droite	Rechter Arbeitstisch eingestellt		310544616
31	Right Worktable	droit de table de travail	Richtiger Arbeitstisch	1	NA
33	Right Stop Plate	Plaque d'arrêt droite	Rechte Stopplatte t2	1	NA
12	Extension Rod (Long)	Rod Extension (longue)	Verlängerungsstange (lang)	1	NA
13	Extension Rod (Short)	Rod Extension (Short)	Verlängerungsstange (kurz)	1	NA
14	Hex Nut, Nylon Lock	Écrou hexagonal, Nylon verrouillage	Sechskantmutter, Nylonschloss	1	NA
16	Socket Set Screw	Jeu de douilles à vis	Innensechskantschraube	2	NA
18	Pan Head Machine Screw	Vis à tête cylindrique	Pan Head Maschinenschraube	1	NA
19	Flat Washer	rondelle plate	Unterlegscheibe	2	NA
232	Fence set	Kit guide de rotation	Zaun gesetzt		310544617
3	Pan Head Machine Screw	Vis à tête cylindrique	Pan Head Maschinenschraube	2	NA
22	Lock Handle	Poignée de verrouillage	Griff verriegeln	2	NA
23	Lock Bolt (RH threads)	Boulon de verrouillage (filetages SR)	Sicherungsbolzen (Gewinde rechts)	1	NA
25	Flat Washer	rondelle plate	Unterlegscheibe	4	NA
26	Lock Washer	rondelle épaisse	Sicherungsscheibe	4	NA
27	Socket Head Cap Screw	Vis à tête creuse	Innensechskantschraube	4	NA
28	Lock Bolt (LH threads)	Boulon de verrouillage (filetages G)	Verriegelungsbolzen (linke Gewinde)	2	NA
29	Fence	Guide de rotation	Zaun	1	NA
216	Socket Set Screw	Jeu de douilles à vis	Innensechskantschraube M6 x 16	2	NA

Rail assembly / assemblage rail / Wagen

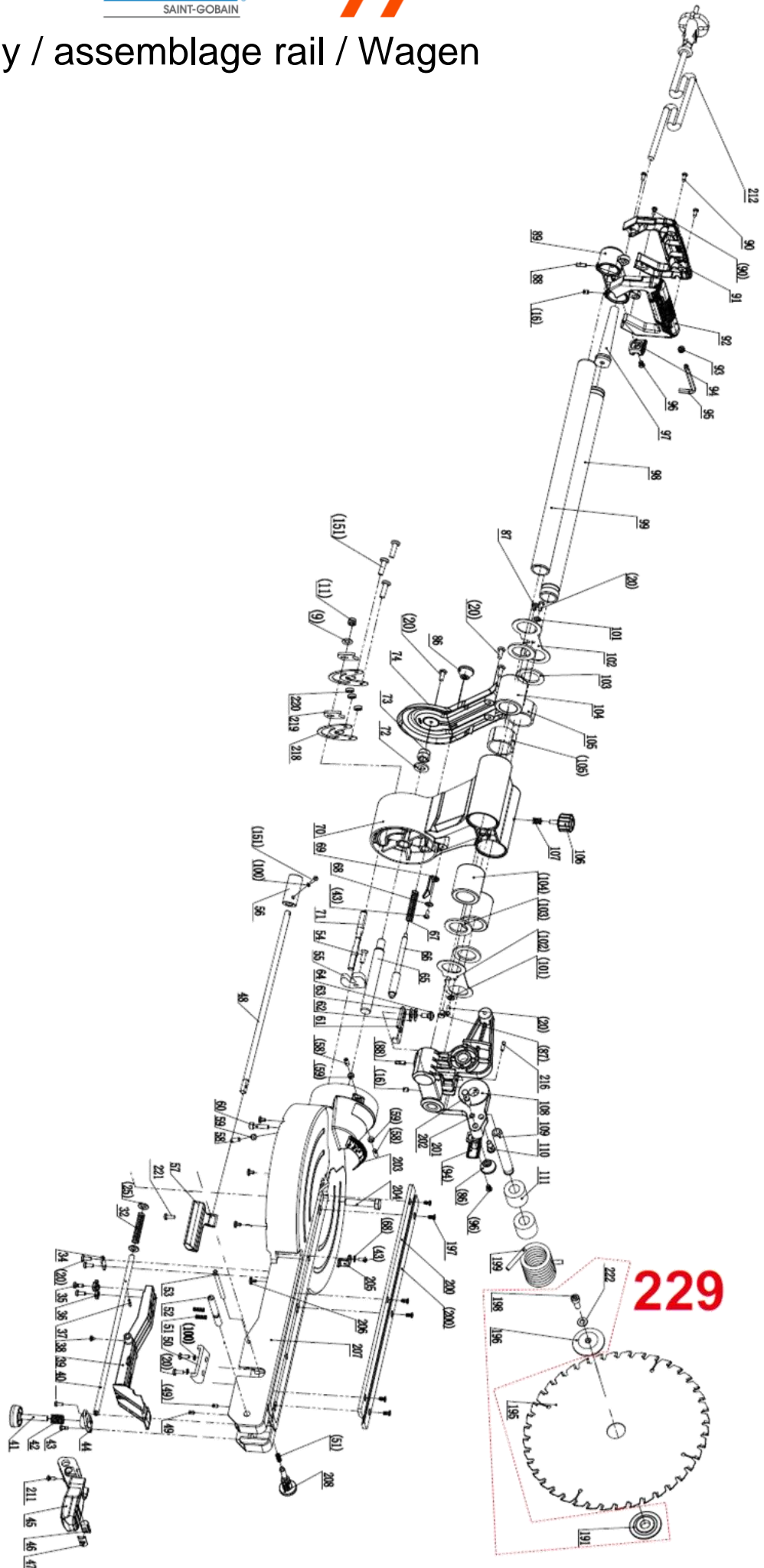

POS.	DESCRIPTION	DESCRIPTION	BESCHREIBUNG	QTY	REF
34	Plate t1.5	assiette t1.5	Platte t1.5	1	310544009
35	Self-Tapping Screw ST4.8x13 (F)	Vis autotaraudeuse ST4.8x13 (F)	Selbstschneidende Schraube ST4.8 x 13 (F)	1	NA
36	Fixed Block	Bloc fixe	Block behoben	1	310544349
37	Roll Pin 3x16	Goupille 3x16	Rollstift 3 x 16	1	310544350
38	Self-Tapping Screw ST4x8	Vis autotaraudeuse ST4x8	Selbstschneidende Schraube ST4 x 8	1	310544351
39	Fixed Block	Bloc fixe	Block behoben	1	310544352
40	Locking Rod	Barre de verrouillage	Verriegelungsstange	1	310544353
41	Adjustable Foot	ped réglable	Verstellbarer Fuß	1	310544354
42	Spring	Ressort	Feder	1	310544355
43	Pan Head Machine Screw M4x12	Vis à tête cylindrique M4x12	Pan Head Maschinenschraube M4 x 12	1	NA
44	Support	Support	Unterstützung	1	310544356
45	Lock Handle	Poignée de verrouillage	Griff verriegeln	1	310544343
46	Adjust Pin	Goupille de réglage	Pin einstellen	1	310544344
47	Locking Block	Bloc de verrouillage	Sperrblock	1	310544345
48	Locking Rod	Barre de verrouillage	Verriegelungsstange	1	310544376
49	Socket Set Screw M5x8	Jeu de douilles à vis M5x8	Innensechskantschraube M5 x 8	1	NA
50	Stop Plate t2.5	plaque d'arrêt t2.5	Stopplatte t2.5	1	310544377
51	Spring	Ressort	Feder	1	310544378
52	Lock Axis	Axe de verrouillage	Achse sperren	1	310544379
53	Locating Axis	Axis localisation	Achse lokalisieren	1	310544380
54	Socket Head Flat Screw M5x20	vis à tête plate M5x20	Innensechskantschraube M5 x 20	1	310544381
55	Stop Plate	plaque d'arrêt	Stopplatte	1	310544382
56	Sleeve	Manche	Ärmel	1	310544383
57	Lock Handle	Poignée de verrouillage	Griff verriegeln	1	310544384
58	Socket Set Screw M6x20	Jeu de douilles à vis M6x20	Innensechskantschraube M6 x 20	1	310544385
59	Washer	Rondelle	Unterlegscheibe	1	NA
60	Socket Head Cap Screw M6x25	Vis à tête creuse M6x25	Innensechskantschraube M6 x 25	1	NA
61	Stop Plate t2	plaque d'arrêt t2	Stopplatte t2	1	310544386
62	Wave Washer 8/t0.5	Rondelle Ondulée 8/t0.5	Wellenscheibe 8 / t0.5	1	NA
63	Flat Washer t0.5	rondelle plate t0.5	Unterlegscheibe t0.5	1	NA
64	Screw M6	Vis M6	Schraube M6	1	NA
65	Shaft	Arbre	Welle	1	310544387
66	Pin	Goupille	Stift	1	310544388
67	Spring	Ressort	Feder	1	310544389
68	Flat Washer Diam.4	rondelle plate Diam.4	Unterlegscheibe Diam.4	1	NA
69	Pointer	Flèche	Zeiger	1	310544390
70	Support Arm	bras de support	Stützarm	1	310544391
71	Lock Shaft	Arbre de verrouillage	Welle sperren	1	310544392
72	Flat Washer Diam.12	rondelle plate Diam.12	Unterlegscheibe Diam.12	1	NA
73	Hex Nut, Nylon Lock Diam.12	Écrou hexagonal, Nylon verrouillage Diam.12	Sechskantmutter, Nylon Lock Diam.12	1	NA
74	Hex Wrench	Clé hexagonale	Sechskantschlüssel	1	310544393
86	Knob	Bouton	Knopf	1	310544394
87	Washer	Rondelle	Unterlegscheibe	1	NA
88	Pin 5x14	Goupille 5x14	Pin 5 x 14	1	310544395
89	Sleeve	Manche	Ärmel	1	310544398
90	Self-Tapping Screw ST4.2x13	Vis autotaraudeuse ST4.2x13	Selbstschneidende Schraube ST4.2 x 13	1	NA
91	Handle Left	Poignée gauche	Griff links	1	310544315
92	Handle Right	poignée droite	Rechts handhaben	1	310544406
93	Grommet	Oeillet	Tülle	1	310544407
94	Cord Holder	Support de cordon	Kabelhalter	1	310544408
95	Hex Wrench with Cross Point Diam.6	Clé hexagonale Diam.6	Inbusschlüssel mit Kreuzungspunkt Diam.6	1	310544409
96	Socket Head Flat Screw M5x10	vis à tête plate de la prise M5x10	Innensechskantschraube M5 x 10	1	NA
97	Protective Sleeve	protection de cable	Schutzhülle	1	310544410
98	Slide Bar, Right	Barre coulissante, Droite	Schieberegler rechts	1	310544411
99	Slide Bar, Left	Barre coulissante, Gauche	Schieberegler links	1	310544412
100	Lock Washer Diam.5	Rondelle Diam.5	Sicherungsscheibe Diam.5	1	NA
101	Flat Washer Diam.5	rondelle plate Diam.5	Unterlegscheibe Diam.5	1	NA
102	Bearing Plate	Plaque d'appui	Lagerplatte	1	310544413

Rail assembly / assemblage rail / Wagen

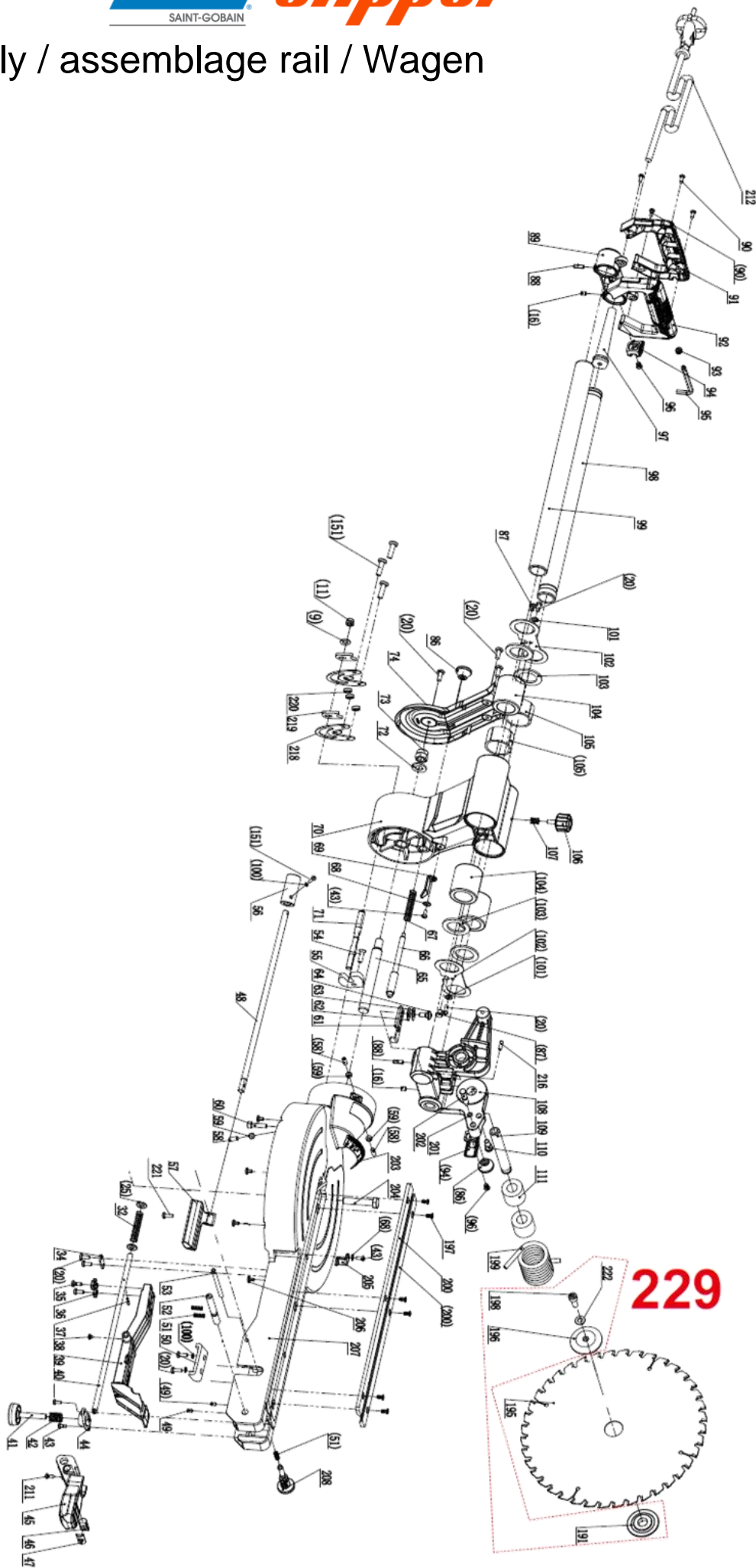

POS.	DESCRIPTION	DESCRIPTION	BESCHREIBUNG	QTY	REF
103	Felt	Rondelle Feutre	Fühlte	1	310544414
104	Bearing	Roulement	Lager	1	310544415
105	Bearing Sleeve	Palier à douille	Lagerhülse	1	310544416
106	Knob	Bouton	Knopf	1	310544417
107	Spring	Ressort	Feder	1	310544418
108	Support	Support	Unterstützung	1	310544419
109	Shaft	Arbre	Welle	1	310544420
110	Screw	Vis	Schraube	1	310544429
111	Sleeve	Manche	Ärmel	1	310544430
195	Blade	Lame	Klinge	1	NA
197	Adaptor	Adaptateur	Adapter	1	NA
199	Spring	Ressort	Feder	1	310544511
200	Table Insert	Insère de table	Tabelleneinfügung	1	310544586
201	O-Ring $\Phi 5 \times \Phi 1.8$	O-Ring $\Phi 5 \times \Phi 1.8$	O-Ring $\Phi 5 \times \Phi 1.8$	1	310544587
202	Pin	Goupille	Stift	1	310544588
203	Bevel Angle Scale	Echelle d'anle en biseau	Abschrägungswinkelskala	1	310544589
204	Hex Cap Screw M10x55	Vis hexagonal M10x55	Sechskantschraube M10 x 55	1	NA
205	Pointer	Aiguille	Zeiger	1	310544590
206	Friction Pad	Patin de friction	Reibbelag	1	310544591
207	Table	Table	Tabelle	1	310544592
208	Pin	Goupille	Stift	1	310544593
211	Self-Tapping Screw ST4.2x9.5	Vis autotaraudeuse ST4.2x9.5	Selbstschneidende Schraube ST4.2 x 9.5	1	310544595
212	Power Cord	Cordon d'alimentation	Netzkabel	1	310544596
216	Socket Set Screw M6x16	Jeu de douilles à vis M6x16	Innensechskantschraube M6 x 16	1	NA
218	Friction Pad	Patin de friction	Reibbelag	1	NA
219	Washer t3	Rondelle t3	Unterlegscheibe t3	1	NA
220	Sleeve	Manche	Ärmel	1	NA
229	Flange set	Kit flasque	Flanschsatz	1	310544604
191	Screw	Vis	Schraube	1	NA
196	Outer Flange	Flasque mobile	Außenflansch	1	NA
198	Screw (LH Threads)	Vis (Pas à gauche)	Schraube (linke Gewinde) M8 x 20-links	1	NA
222	Thick washer	rondelle épaisse	Dicke Unterlegscheibe Diam.8	1	NA

Blade guard / carter de lame / Mhlsteinbaum

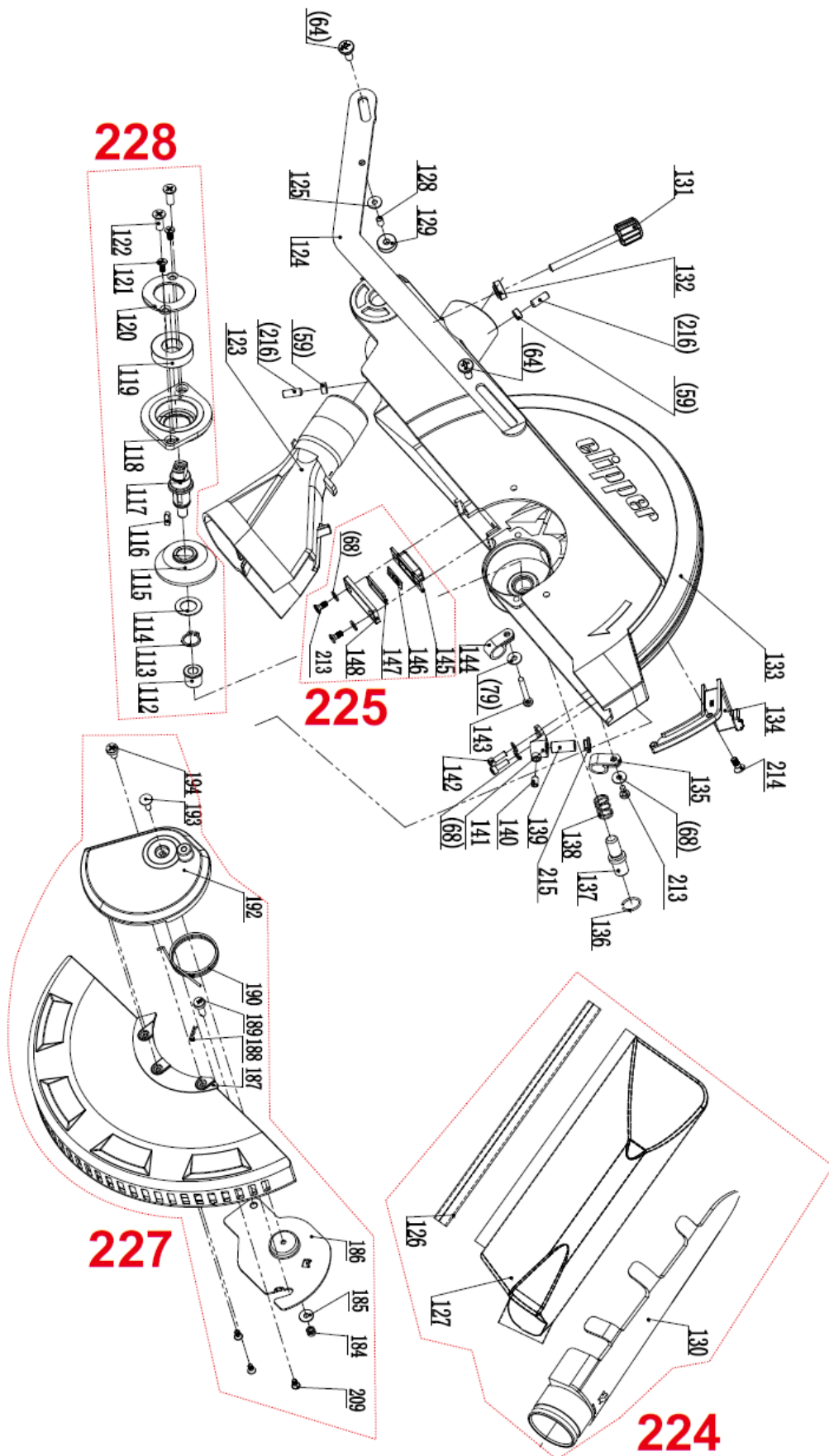

POS.	DESCRIPTION	DESCRIPTION	BESCHREIBUNG	QTY	REF
123	Dust Exhaust	échappement poussière	Staubabgas	1	310544432
124	Linkage Bar Diam.3	Bar de liaison Diam.3	Verbindungsstange Diam.3	1	310544433
125	Washer Diam.6	Rondelle Diam.6	Unterlegscheibe Diam.6	1	NA
128	Pin	Goupille	Stift	1	310544439
129	Bearing	Palier	Lager	1	310544442
131	Knob	Bouton	Knopf	1	310544447
132	Nut M6	Écrou M6	Mutter M6	1	310544446
133	Blade guard	Blade guard	Klingenschutz	1	310544449
134	Support Piece	Pièce de support	Stützstück	1	310544450
135	Cable Clip	cabl clip	Kabelclip	1	310544451
136	Retaining Ring $\phi 10.5 \times \phi 1$	Anneau de retenue $\phi 10.5 \times \phi 1$	Sicherungsring $\phi 10,5 \times \phi 1$	1	NA
137	Pin	Goupille	Stift	1	NA
138	Spring	Ressort	Feder	1	310544452
139	Laser Unit	laser	Lasereinheit	1	310544453
140	Socket Set Screw M6x6	Jeu de douilles à vis M6x6	Innensechskantschraube M6 x 6	1	310544454
141	Laser Seat	Logement de Laser	Lasersitz	1	310544455
142	Socket Head Cap Screw M4x12	Vis à tête creuse M4x12	Innensechskantschraube M4 x 12	1	NA
143	Self-Tapping Screw ST4.2x40 (F)	Vis autotaraudeuse ST4.2x40 (F)	Selbstschneidende Schraube ST4.2 x 40 (F)	1	NA
144	Cable Clip	cabl clip	Kabelclip	1	310544456
214	Self-Tapping Screw M4x10	Vis autotaraudeuse M4x10	Selbstschneidende Schraube M4 x 10	1	NA
224	Dust Bag set	Sac d'aspirateur	Staubbeutel-Set	1	310544599
126	Clip	maintien	Clip	1	NA
127	Dust Bag	Sac d'aspirateur	Staubbeutel	1	NA
130	Plastic Frame	Châssis en plastique	Plastik Rahmen	1	NA
225	led light set	Kit lumière	LED-Licht eingestellt	1	310544600
68	Flat Washer	rondelle plate	Unterlegscheibe Diam.4	7	NA
145	Light Box	Boite à lumière	Lichtkasten	1	NA
146	LED Light	Lumière LED	LED-Licht	1	NA
147	Seal	Joint	Dichtung	1	NA
148	Lens	Lentille	Linse	1	NA
213	Self-Tapping Screw	Vis autotaraudeuse	Selbstschneidende Schraube M4 x 12	3	NA
227	blade guard assembly	Ensemble carter de disque	Klingenschutzbaugruppe	1	310544602
184	Hex Nut, Nylon Lock	Écrou hexagonal, Nylon	Sechskantmutter, Nylonschloss M5	1	NA
185	Flat Washer	rondelle plate	Unterlegscheibe Diam.5	1	NA
186	Fixed Plate	plaque fixe	Feste Platte	1	NA
187	Blade Guard	Carter de disque	Klingenschutz	1	NA
188	Pin	Goupille	Stift	1	NA
189	Screw	Vis	Schraube M6	1	NA
190	Spring	Ressort	Feder	1	NA
192	Support Plate	Plaque de support	Stützplatte	1	NA
193	Carriage Bolt	Ecrou du chariot	Schliittenschraube M5 x 16	1	NA
194	Inner Flange	Flasque fixe	Innenflansch M6	1	NA
209	Socket Head Flat Screw	vis à tête plate de prise	Innensechskantschraube M4 x 10	3	NA
228	Blade bearing set	Roulement du disque	Klingenbärenset		310544603
112	Bearing	Roulement	Lager	1	NA
113	C-Retaining Ring, Ext	Circlipse	C-Sicherungsring, ext	1	NA
114	Washer	Rondelle	Unterlegscheibe	1	NA
115	Gear	Pignon	Ausrüstung	1	NA
116	Key, Dbl Rd Hd	Clavette	Schlüssel, Dbl Rd Hd 4 x 12	1	NA
117	Arbor	Tonnelle	Laube	1	NA
118	Gear Cover	couvercle du pignon	Getriebeabdeckung	1	NA
119	Bearing	Palier	Lager	1	NA
120	Plate	Plat	Teller	1	NA
121	Socket Head Flat Screw	vis à tête plate de prise	Innensechskantschraube M4 x 10	2	NA
122	Socket Head Flat Screw	vis à tête plate de prise	Innensechskantschraube M6 x 16	2	NA
119	Bearing	Palier	Lager	1	NA

Motor Assembly / Assemblage moteur

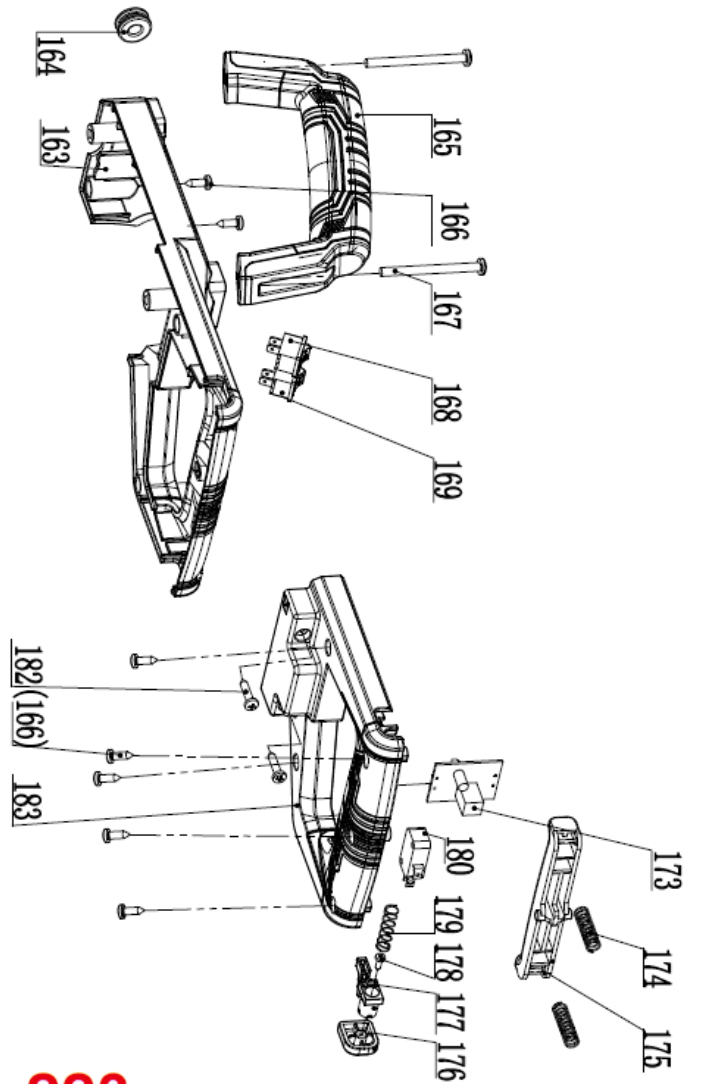

223

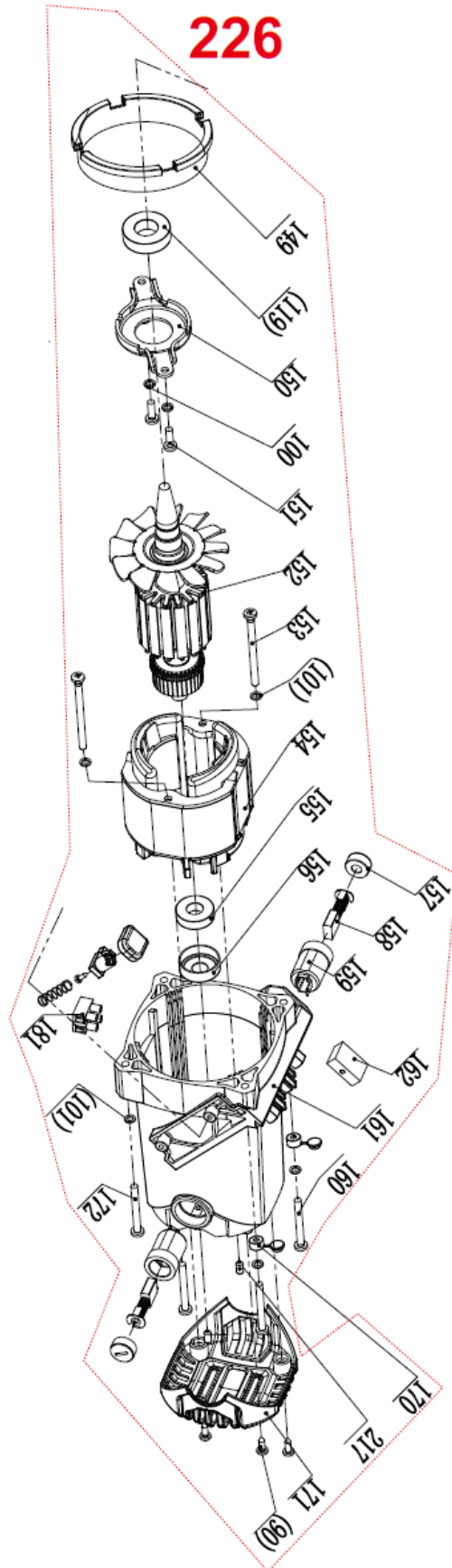
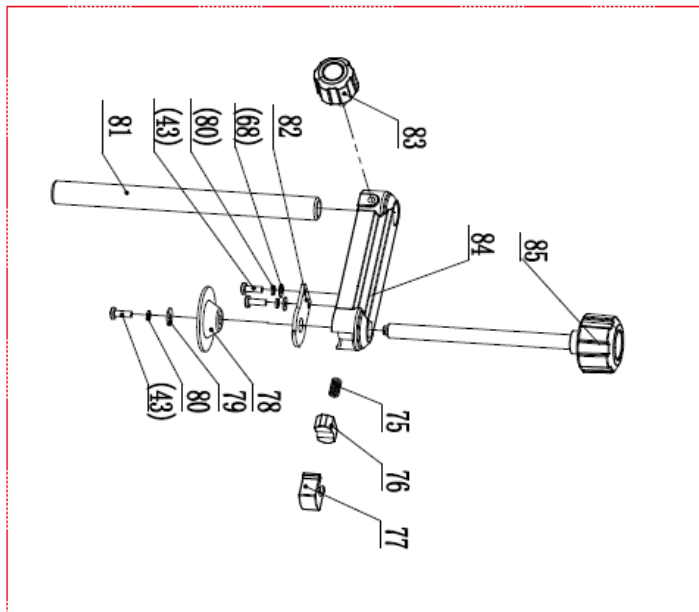

POS.	DESCRIPTION	DESCRIPTION	BESCHREIBUNG	QTY	REF
163	Upper Handle	Poignée supérieure	Oberer Griff	1	310544487
164	Grommet	Oeillet	Tülle	1	310544488
165	Handle	Poignet	Griff	1	310544489
166	Self-Tapping Screw ST4.2x16	Vis autotaraudeuse ST4.2x16	Selbstschneidende Schraube ST4.2 x 16	1	NA
167	Pan Head Machine Screw M5x60	Vis à tête cylindrique M5x60	Pan Head Maschinenschraube M5 x 60	1	NA
168	Laser Switch	Commutateur laser	Laserschalter	1	310544490
169	LED Light Switch	LED Light Switch	LED Lichtschalter	1	310544491
173	Controller Assembly	Ensemble de contrôle	Controller-Baugruppe	1	310544492
174	Spring	Ressort	Feder	1	310544493
175	Trigger	Déclencheur	Auslösen	1	310544494
176	Button	Bouton	Taste	1	310544506
177	Button	Bouton	Taste	1	310544507
178	Self-Tapping Screw ST2.9x9.5	Vis autotaraudeuse ST2.9x9.5	Selbstschneidende Schraube ST2.9 x 9.5	1	NA
179	Spring	Ressort	Feder	1	310544508
180	Trigger Switch	gâchette	Auslöseschalter	1	310544509
181	Terminal PA10	Terminal PA10	Terminal PA10	1	NA
182	Self-Tapping Screw ST4.2x19	Vis autotaraudeuse ST4.2x19	Selbstschneidende Schraube ST4.2 x 19	1	NA
183	Lower Handle	Poignée inférieure	Unterer Griff	1	310544510
223	Press workpiece device assembly	Serre joint	Werkstückbaugruppe drücken	1	310544598
75	Spring	Ressort	Feder	1	NA
76	Locking Block	Bloc de verrouillage	Sperrblock	1	NA
77	Button	Bouton	Taste	1	NA
78	Plate	Plat	Platte t2	1	NA
79	Washer	Rondelle	Unterlegscheibe Diam.4	2	NA
80	Lock Washer	Rondelle	Sicherungsscheibe Diam.4	3	NA
81	Post	Tige	Post	1	NA
82	Plate	Plat	Platte t2.5	1	NA
83	Knob	Bouton	Knopf	1	NA
84	Clamp Support	Soutien de serrage	Klemmhalterung	1	NA
85	Handle	Poignet	Griff	1	NA
226	Motor assembly	Ensemble moteur	Motormontage	1	310544601
90	Self-Tapping Screw	Vis autotaraudeuse	Selbstschneidende Schraube ST4.2 x 13	8	NA
101	Flat Washer	rondelle plate	Unterlegscheibe Diam.5	8	NA
119	Bearing	Palier	Lager	2	NA
149	Deflector	Déflexeur	Deflektor	1	NA
150	Motor Plate	plaque moteur	Motorplatte	1	NA
151	Pan Head Machine Screw	Vis à tête cylindrique	Pan Head Maschinenschraube M5 x 16	2	NA
152	Armature	Armature	Anker	1	310544403
153	Pan Head Machine Screw	Vis à tête cylindrique	Pan Head Maschinenschraube M5 x 70	2	NA
154	Stator	stator	Stator	1	310544404
155	Ball Bearing	Roulement à billes	Kugellager	1	310544405
156	Damping Ring	Bague Damping	Dämpfungsring	1	310616324
157	Cap	Chapeau	Deckel	2	310544472
158	Carbon Brush	Couvercle	Kohlebürste	2	310544473
159	Brush Holder	Porte-balais	Bürstenhalter	2	310544474
160	Pan Head Machine Screw	Vis à tête cylindrique	Pan Head Maschinenschraube M5 x 45	2	NA
161	Motor Housing	logement moteur	Motorgehäuse	1	NA
162	Capacitor	Condensateur	Kondensator	1	310544475
170	Screw Cap	Cache de vis	Schraubverschluss	2	NA
171	Motor Cover	Capot du moteur	Motorabdeckung	1	NA
172	Pan Head Machine Screw	Vis à tête cylindrique	Pan Head Maschinenschraube M5 x 35	2	NA
217	Socket Set Screw	Jeu de douilles à vis	Innensechskantschraube M5 x 8	2	NA

SAINT-GOBAIN ABRASIVES
INDUSTRIEWEG 21
9420 ERPE-MERE
BELGIUM
TEL: +32(0) 2 267 21 00

SAINT-GOBAIN ABRASIVES, S.R.O.
POČERNICKÁ 272/96, MALEŠICE
108 00 PRAHA 10
CZECH REPUBLIC
TEL: +420 255 719 326
FAX: +420 255 719 321

SAINT-GOBAIN ABRASIVES A/S
DYBENDALSVEENGET 2,
DK-2630 TAASTRUP
DENMARK
TEL: +45 4675 5244

SAINT-GOBAIN ABRASIVES MIDDLE EAST
JEBEL ALI FREE ZONE,
PLOT NO. S10817
PO BOX 261484, DUBAI •
UNITED ARAB EMIRATES
TEL: +971 (4) 8011 800
FAX: +971 (4) 8011 801

SAINT-GOBAIN ABRASIFS
RUE DE L'AMBASSADEUR - B.P.8
78 702 CONFLANS CEDEX
FRANCE
TEL: +33 (0)1 34 90 40 00
FAX: +33 (0)1 39 19 89 56

SAINT-GOBAIN ABRASIVES GMBH
BIRKENSTRASSE 45-49
D-50389 WESSELING
GERMANY
TEL: +49 (0) 2236 703-1
+49 (0) 2236 8996-0
+49 (0) 2236 8911-0
FAX: +49 (0) 2236 703-367
+49 (0) 2236 8996-10
+49 (0) 2236 8911-30

FÜR DEN FACHHANDEL
ÖSTERREICH
TEL: +43 (00) 662 430 076

SAINT-GOBAIN ABRASIVES KFT.
1225 BUDAPEST
BÁNYALÉG U. 60/B.
HUNGARY
TEL: +36 1 371 22 50
FAX: +36 1 371 22 55

SAINT-GOBAIN ABRASIVI S.P.A
VIA PER CESANO BOSCONI 4
I-20094 CORSICO MILANO
ITALY
TEL: +39 02 44 851
FAX: +39 02 44 78 266

SAINT-GOBAIN ABRASIVES S.A.
190 RUE J.F. KENNEDY
L-4930 BASCHARAGE
GRAND DUCHE DE LUXEMBOURG
TEL: +352 50 401 1
FAX: +331 83 717 792
NO. VERT (FRANCE): 0800 906 903

SAINT-GOBAIN ABRASIFS, S.A.
2 ALLÉE DES FIGUIERS
AIN SEBÂÂ - CASABLANCA
MOROCCO
TEL: +212 5 22 66 57 31
FAX: +212 5 22 35 09 65

SAINT-GOBAIN ABRASIVES BV
GROENLOSEWEG 28
7151 HW EIBERGEN
P.O. BOX 10
7150 AA EIBERGEN
THE NETHERLANDS
TEL: +31 545 466466
FAX: +31 545 474605

SAINT-GOBAIN ABRASIVES AS
POSTBOKS 11, ALNABRU, 0614 OSLO
BROBEKKVEIEN 84,
0582 OSLO • NORWAY
TEL: +47 63 87 06 00
FAX: +47 63 87 06 01

SAINT-GOBAIN HPM POLSKA SP. Z O.O.
UL. NORTON 1,
62-600 KOŁO • POLAND
TEL: +48 63 26 17 100
FAX: +48 63 27 20 401

SAINT-GOBAIN ABRASIVOS, L. DA
ZONA INDUSTRIAL DA MAIA
I-SECTOR VIII, NO. 122
APARTADO 6050
4476 - 908 MAIA
PORTUGAL
TEL: +351 229 437 940
FAX: +351 229 437 949

SAINT-GOBAIN GLASS
BUSINESS UNIT ABRASIVI
PUNCT DE LUCRU : LOC.VETIS, JUD.
SATU MARE 447355
STR. CAREIULUI 11
PARC INDUSTRIAL RENOVATIO
ROMANIA
TEL: +40 261 839 709
FAX: +40 261 839 710

SG HPM RUS
58, F. ENGELS STR.
STROENIE 2
105082 MOSCOW
RUSSIA
TEL: +74 955 408 355
FAX: +74 959 373 224

SAINT-GOBAIN
ABRASIVES (PTY) LTD
2 MONTEER ROAD
ISANDO 1600
P.O. BOX 67
SOUTH AFRICA
TEL: +27 11 961 2000
FAX: +27 11 961 2184/5

SAINT-GOBAIN ABRASIVOS, S.A.
CTRA. DE GUIPÚZCOA, KM. 7,5
E-31195 BERRIOPLANO (NAVARRA)
SPAIN
TEL: +34 948 306 000
FAX: +34 948 306 042

SAINT GOBAIN ABRASIVES AB
GÅRDSFOGDEVÄGEN 18A
168 66 BROMMA • SVERIGE
SWEDEN
TEL: +46 8 580 881 00
FAX: +46 8 580 881 30

SAINT-GOBAIN INOVATIF MALZEMELER VE
ASINDIRICI SAN. TIC. AS.
ALTAYÇEŞME MAH. ÇAMLI SOK. NO:21 ESAS
OFISPAK KAT:9 34843
MALTEPE, İSTANBUL • TURKEY
TEL: 0090-216-217 12 50
FAX: 0090-216-442 40 74

SAINT-GOBAIN ABRASIVES LTD.
DOXEY RD
STAFFORD
ST16 1EA
UNITED KINGDOM
TEL: +44 1785 222 000
FAX: +44 1785 213 487



Saint-Gobain Abrasifs
190 Rue J.F. Kennedy
L-4930 Bascharage
Grand Duché de Luxembourg
Tel: +331 83 717 792
Fax: +352 50 16 33
no. vert (France) 0800 906 903

www.nortonabrasives.com/fr-fr