

# CDP 301/351

SPARE PART LIST

LISTE DE PIECES DE RECHANGE

ERSATZTEILLISTE

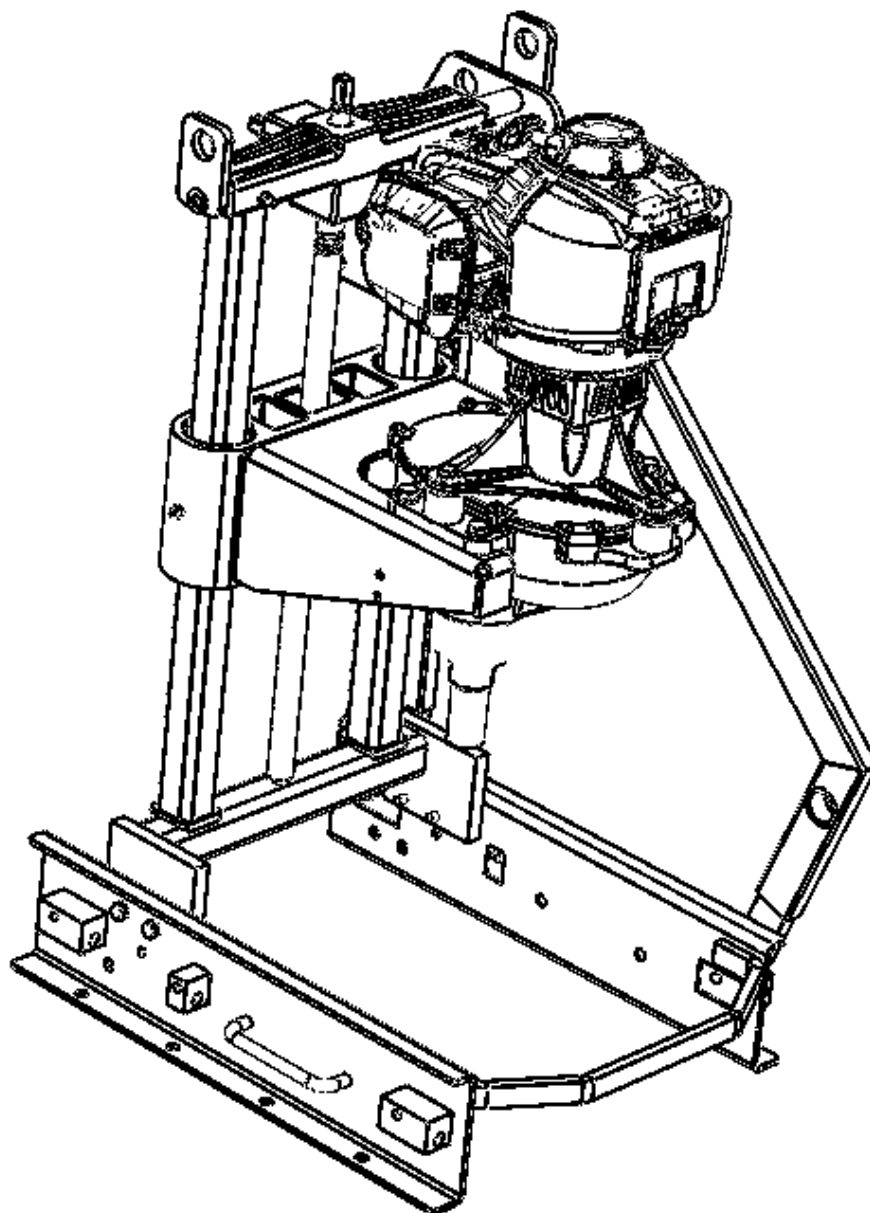

## TYPE:

S = Spare part  
W = Wear part  
NA = Not Available

The kits of spare parts contain all screws and bolts and the components referring itself to it. Screws and bolts is component of standard assembly, which you can easily find at all the retailers of standard components of assembly.  
All the components of standard assembly are of a quality grade 8.8.  
We recommend not to use a quality grade lower than 8.8 for all the standard components of assembly.

The parts of replacements CLIPPER must always be used.  
The wearing parts have one lifetime limited in time because of a normal use of the machine. This lifetime strongly depends on the intensity of use of the machine. The wearing parts are to be maintained, use and to change if necessary according to the indications of manufacturing.  
A wear because of normal use of the machine does not give the right to a warranty.  
The components NA (Not Available) are not available in spare part.

## TYPE :

S = Pièce de rechange  
W = Pièce d'usure  
NA = Non disponible

Les kits de pièces détachées contiennent toute la visserie et les composants s'y rapportant. La visserie est un composant d'assemblage standard, que vous pouvez facilement trouver chez tous les détaillants de composants d'assemblage standards.  
Tous les composants d'assemblage standard sont d'une classe de qualité 8.8.  
Nous recommandons de ne pas utiliser une classe de qualité inférieure à 8.8 pour tous les composants d'assemblage standards.

Les pièces de remplacements CLIPPER doivent toujours être utilisées.  
Les pièces d'usure ont une durée de vie limitée dans le temps du fait d'une utilisation normale de la machine. Cette durée de vie dépend fortement de l'intensité d'utilisation de la machine. Les pièces d'usure sont à entretenir, à utiliser et le cas échéant à changer selon les indications du fabricant.  
Une usure du fait de l'utilisation normale de la machine ne donne pas droit à une garantie.  
Les composants NA (Not Available) ne sont pas disponibles en pièce de rechange.

## TYP :

S = Ersatzteile  
W = Verschleißteile  
NA = nicht verfügbare

Die definierten Ersatzteil-Set's beinhalten alle Ersatzteile wie Komponenten, Schrauben, Muttern etc. Norm- bzw. Standardteile wie Schrauben, Muttern etc. können bei offiziellen Schrauben- sowie Komponentenhändler bezogen werden.  
Alle Norm- bzw. Standardteile wie Schrauben, Muttern etc. entsprechen der Qualitäts- bzw. Festigungsklasse 8.8.  
Wir empfehlen, keine Norm- bzw. Standardteile wie Schrauben, Muttern etc. unter der Qualitäts- bzw. Festigungsklasse 8.8 einzusetzen.

Es dürfen nur geprüfte CLIPPER-Ersatzteile eingesetzt werden.  
Die Lebensdauer der Verschleißteile ist bei einer bestimmungsgemäßer Anwendung begrenzt. Die Lebensdauer hängt stark von der Intensität der Benutzung der Maschine ab. Die Verschleißteile sind entsprechend der Betriebsanleitung des Herstellers zu warten und gegebenenfalls auszutauschen. Ein Verschleiß bei normaler bestimmungsgemäßen Anwendung bedingt keine Mängelansprüche.  
Ersatzteile sowie Komponenten mit dem Vermerk NA (NA=nicht verfügbar) sind nicht verfügbar.

## Summary / Sommaire / Index

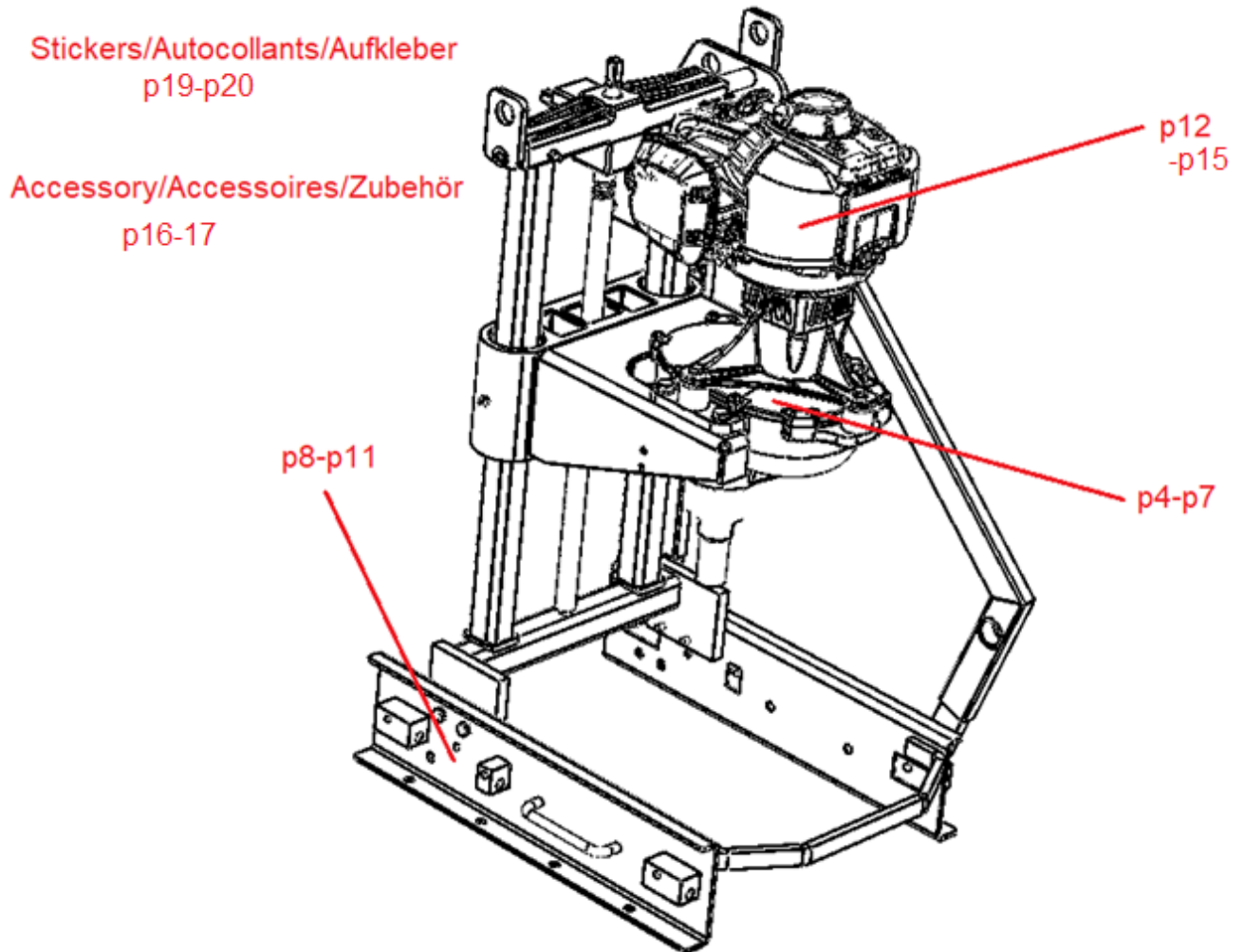

# Gearbox / Boîte de vitesse / Getriebe

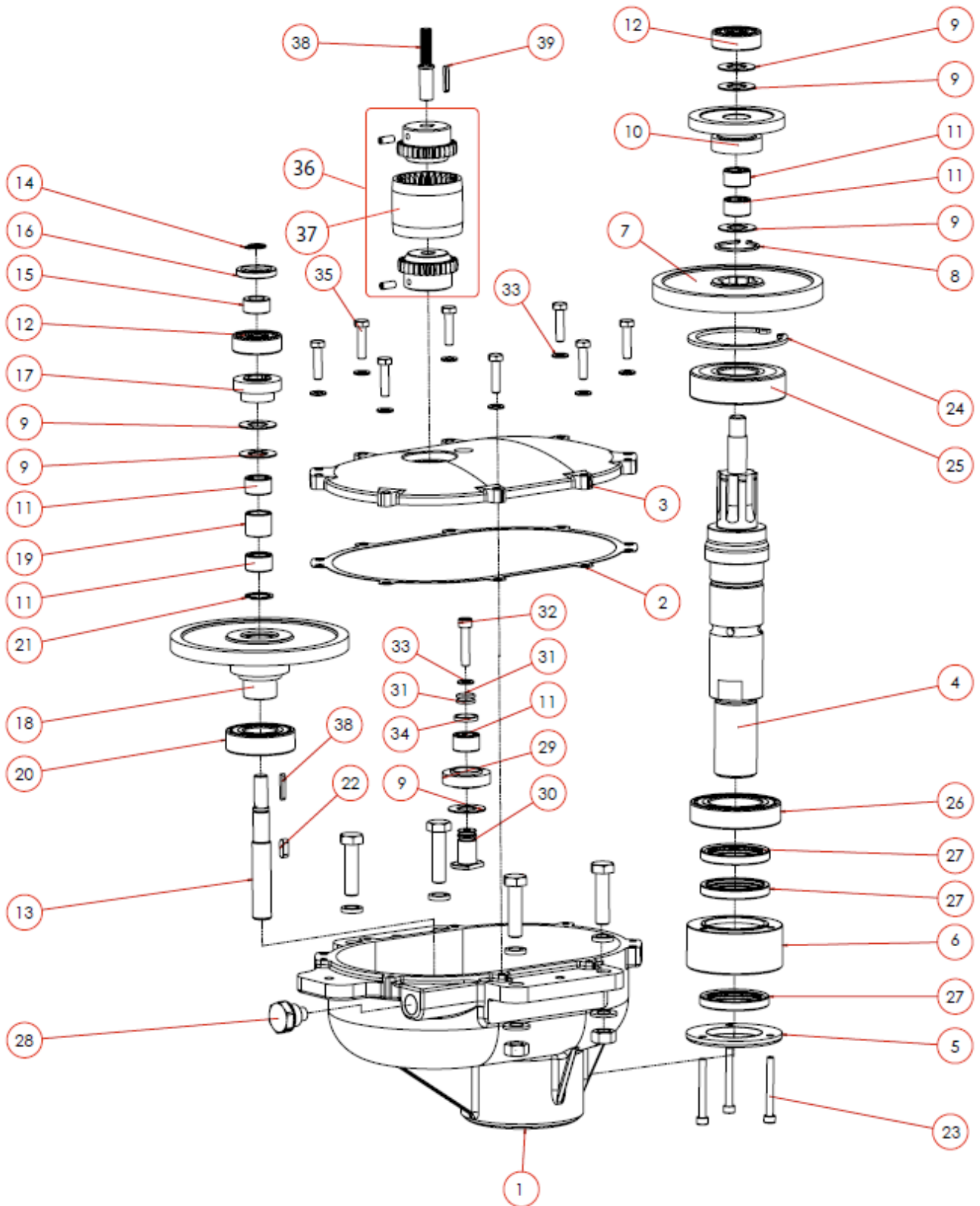

POS	DESCRIPTION EN	DESCRIPTION FR	BESCHREIBUNG	REF	QTY	TYP
1	Bottom casing	Carter inférieur	Untere gehäuse	510136910	1	S
2	Sealing gasket	Joint d'étanchéité	Dichtungsring	510136911	1	W
3	Casing cover	Couvercle de carter	Deckelgehäuse	510136912	1	S
4	Main shaft	Arbre principal	Hauptwelle	510136913	1	W
5	Water collector cap	Bouchon collecteur d'eau	Wasserverteiler Stopfen	510136914	1	S
6	Water collector	Collecteur d'eau	Wasserverteiler	510136915	1	S
7	Gear Z=41 m=2	Pignon Z=41 m=2	Zahnrad Z=41 m=2	510136916	1	S
8	Spring ring DIN 471 - Ø30x1,5	Circlip DIN 471 - Ø30x1,5	Sicherungsring DIN 471 - Ø30x1,5	510136917	1	S
9	Ring SKF - Ref: AS 1528	Bague SKF - Ref: AS 1528	Ring SKF - Ref: AS 1528	510136918	1	W
10	Gear Z=51 m=2 / Z=15 m=2	Pignon Z=51 m=2 / Z=15 m=2	Zahnrad Z=51 m=2 / Z=15 m=2	510136919	1	S
11	Needle bearing SKF - Ref: HK 1412	Roulement à aiguilles SKF - Ref: HK 1412	Nadellager SKF - Ref: HK 1412	510136920	1	W
12	Bearing INA - Ref: 6301-2RSR	Palier INA - Ref: 6301-2RSR	Lager INA - Ref: 6301-2RSR	510136921	1	W
13	Engine shaft	Arbre moteur	Motorwelle	510136882	1	S
14	Spring ring DIN 471 - Ø12x1	Circlip DIN 471 - Ø12x1	Sicherungsring DIN 471 - Ø12x1	510136883	1	S
15	Pressure ring Øext 20 Øint 12K6 H=10	Rondelle de pression Øext 20 Øint 12K6 H=10	Druckscheibe Øext 20 Øint 12K6 H=10	510136924	1	S
16	Gasket PAULSTRA - Ref: 722342	Joint d'étanchéité PAULSTRA - Ref: 722342	Dichtungsring PAULSTRA - Ref: 722342	510136925	1	W
17	Gear Z=31 m=2	Pignon Z=31 m=2	Zahnrad Z=31 m=2	510136926	1	S
18	Gear Z=49 m=2,5 / Z=12 m=2	Pignon Z=49 m=2,5 / Z=12 m=2	Zahnrad Z=49 m=2,5 / Z=12 m=2	510136927	1	S
19	Spacer Øext 19,5 Øint 14,5 H=17	Entretoise Øext 19,5 Øint 14,5 H=17	Distanzring Øext 19,5 Øint 14,5 H=17	510136928	1	S
20	Bearing INA - Ref: 6205-2Z	Palier INA - Ref: 6205-2Z	Lager INA - Ref: 6205-2Z	510136929	1	W
21	Spring ring DIN 472 - Ø20x1	Circlip DIN 472 - Ø20x1	Sicherungsring DIN 472 - Ø20x1	510136930	1	S

# Gearbox / Boîte de vitesse / Getriebe

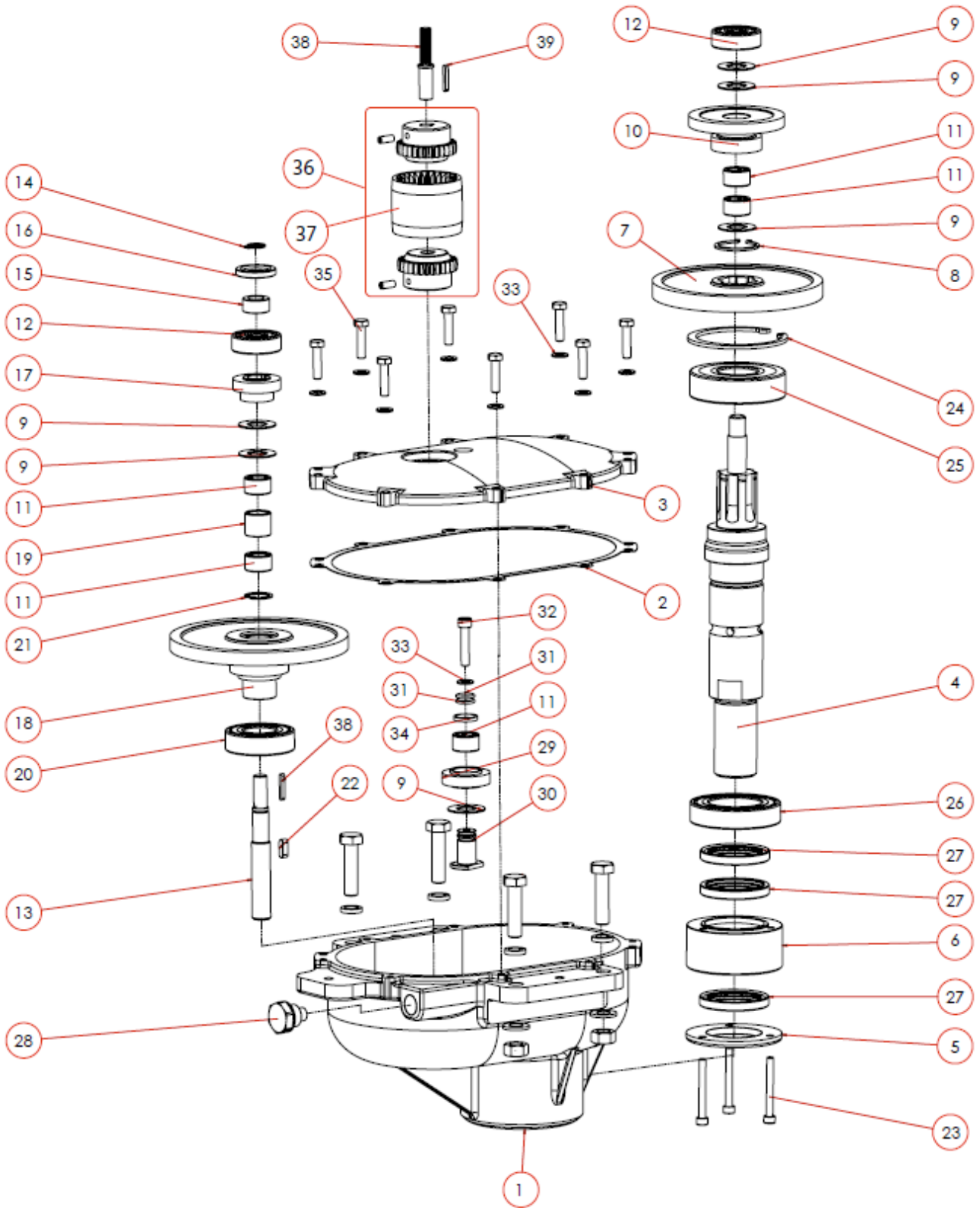

POS	DESCRIPTION EN	DESCRIPTION FR	BESCHREIBUNG	REF	QTY	TYP
22	Key DIN 6885 - 5x5x14	Clavette DIN 6885 - 5x5x14	Passfeder DIN 6885 - 5x5x14	510136931	1	S
23	Screw ISO 4762 M5x45 8.8 A3C	Vis ISO 4762 M5x45 8.8 A3C	Schraube ISO 4762 M5x45 8.8 A3C	510136932	1	S
24	Spring ring DIN 472 - Ø72x2,5	Circlip DIN 472 - Ø72x2,5	Sicherungsring DIN 472 - Ø72x2,5	510136933	1	S
25	Bearing INA - Ref: 7306-B-2RS	Palier INA - Ref: 7306-B-2RS	Lager INA - Ref: 7306-B-2RS	510136964	1	W
26	Bearing INA - Ref: 6008-B-2RSR	Palier INA - Ref: 6008-B-2RSR	Lager INA - Ref: 6008-B-2RSR	510136965	1	W
27	Gasket PAULSTRA - Ref: 792505	Joint d'étanchéité PAULSTRA - Ref: 792505	Dichtungsring PAULSTRA - Ref: 792505	510136966	1	W
28	Hydraulic cap NORELEM - Ref: 28026-24038	Bouchon NORELEM - Ref: 28026-24038	Stopfen NORELEM - Ref: 28026-24038	510136967	1	W
29	Gear Z=16 m=2	Pignon Z=16 m=2	Zahnrad Z=16 m=2	510136968	1	S
30	Special pin with double grooves	Goupille spéciale à double gorges	Spezifisch Stift mit zwei Rillen	510136969	1	S
31	O-ring DIN 3771	Joint torique DIN 3771	O-ring DIN 3771	510136970	1	W
32	Screw ISO 4762 M6x30	Vis ISO 4762 M6x30	Schraube ISO 4762 M6x30	510136971	1	S
33	Washer ISO 7089 6N A3C	Rondelle ISO 7089 6N A3C	Scheibe ISO 7089 6N A3C	510136972	1	S
34	Washer Øext 18 Øint 14,5 e=2,5	Rondelle Øext 18 Øint 14,5 e=2,5	Scheibe Øext 18 Øint 14,5 e=2,5	510136973	1	S
35	Screw ISO 4015 M6x25 8.8 A3C	Vis ISO 4015 M6x25 8.8 A3C	Schraube ISO 4015 M6x25 8.8 A3C	510136984	1	S
36	KTR - BoWex M 24 COUPLING	Accouplement KTR - BoWex M 24	Kupplung KTR - BoWex M 24	510136985	1	W
	Gearwheel M24 - Ø10H7	Pignon M24 - Ø10H7	Zahnrad M24 - Ø10H7		2	
	Screw ISO 4029 M5x12	Screw ISO 4029 M5x12	Schraube ISO 4029 M5x12		2	
	Gearwheel housing	Logement pour pignons	Zahnradgehäuse		1	
37	Gearwheel housing	Logement pour pignons	Zahnradgehäuse	510141959	1	W
38	Fluted motor shaft	Arbre moteur cannelé	Kanneliert Motorwelle	510136986	1	W
39	Key DIN 6885 - 3x3x22	Clavette DIN 6885 - 3x3x22	Passfeder DIN 6885 - 3x3x22	510136987	1	S

# Frame / Châssis / Rahmen

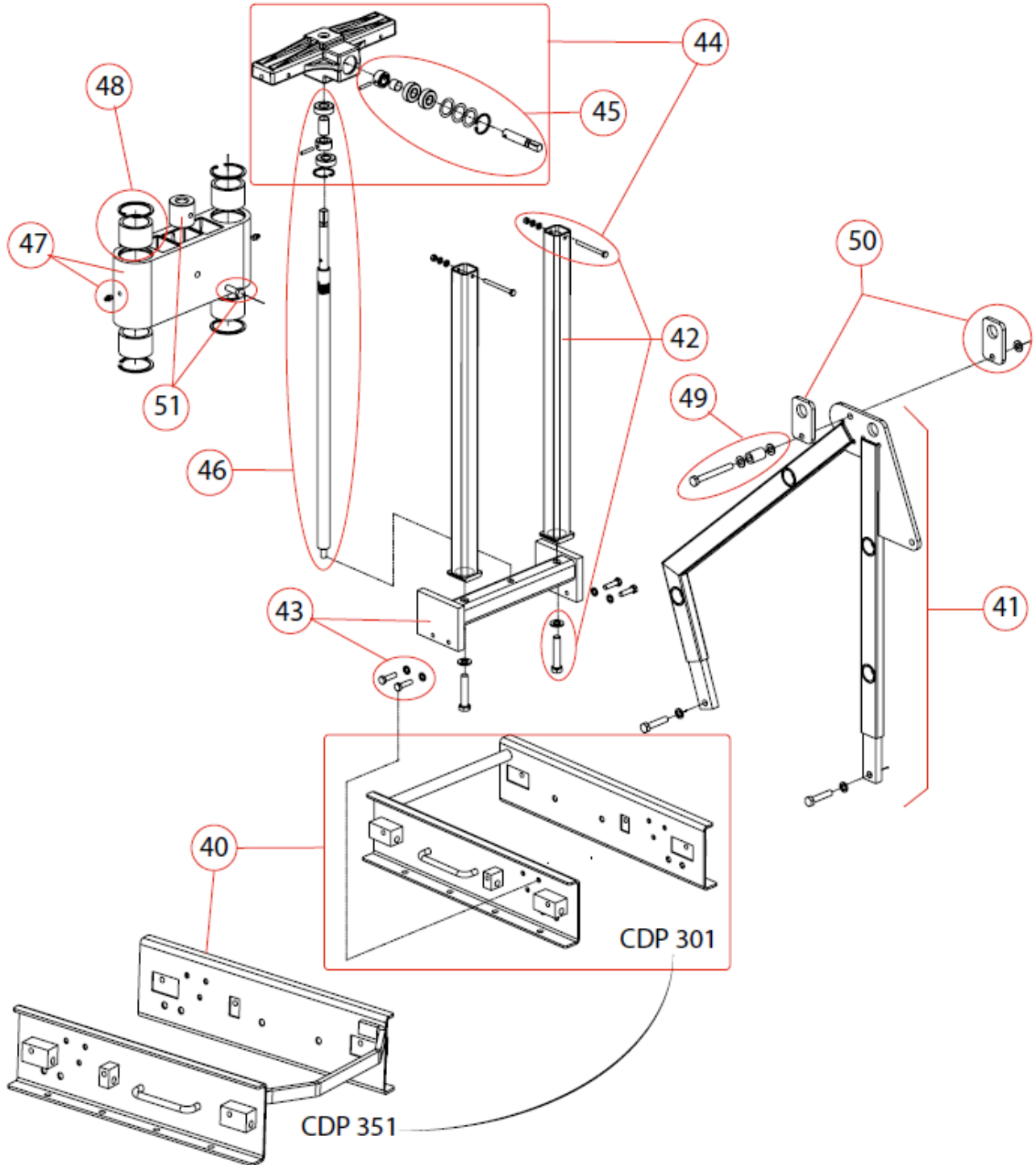



POS	DESCRIPTION EN	DESCRIPTION FR	BESCHREIBUNG	REF	QTY	TYP
<b>40</b>	<b>Base frame welded 300</b>	<b>Châssis soudé de base 300</b>	<b>Basis Rahmen geschweißt 300</b>	<b>510136897</b>	<b>1</b>	<b>S</b>
	Folded plate left	Plaque pliée de gauche	Linke Platte gebogen		1	
	Fastener welded	Attache soudée	Befestigung geschweißt		2	
	Handle side welded	poignée latérale soudée	Seitengriff geschweißt		2	
	Fastener welded	Attache soudée	Befestigung geschweißt		4	
	Folded plate right	Plaque pliée de droite	Rechte Platte gebogen		1	
	Front straight bar	Barre frontale droite	Frontale gerade Schiene		1	
	<b>Base frame welded 350</b>	<b>Châssis soudé de base 350</b>	<b>Basis Rahmen geschweißt 350</b>	<b>510137003</b>	<b>1</b>	<b>S</b>
	Folded plate left	Plaque pliée de gauche	Linke Platte gebogen		1	
	Fastener welded	Attache soudée	Befestigung geschweißt		2	
	Handle side welded	poignée latérale soudée	Seitengriff geschweißt		2	
	Fastener welded	Attache soudée	Befestigung geschweißt		4	
	Folded plate right	Plaque pliée de droite	Rechte Platte gebogen		1	
	Front curved bar	Barre frontale courbée	Frontale gebogen Schiene		1	
<b>41</b>	<b>Lateral frame welded kit</b>	<b>Kit châssis latéral soudé</b>	<b>Seitenrahmen geschweißt Satz</b>	<b>510136898</b>	<b>1</b>	<b>S</b>
	Lateral frame welded	Châssis latéral soudé	Seitenrahmen geschweißt		2	
	Washer DIN 128-10	Rondelle DIN 128-10	Scheibe DIN 128-10		2	
	Screw ISO 4017 M10x50 8-8 A3C	Vis ISO 4017 M10x50 8-8 A3C	Schraube ISO 4017 M10x50 8-8 A3C		2	
<b>42</b>	<b>Column kit</b>	<b>Kit Colonne</b>	<b>Feld Satz</b>	<b>510136899</b>	<b>1</b>	<b>S</b>
	Column welded	Colonne soudée	Feld geschweißt		1	
	Nut ISO 4032 - M12x8	Ecrou ISO 4032 - M12x8	Mutter ISO 4032 - M12x8		1	
	Washer ISO 7089-12	Rondelle ISO 7089-12	Scheibe ISO 7089-12		1	
	Screw ISO 4017 M12x60 8-8 A3C	Vis ISO 4017 M12x60 8-8 A3C	Schraube ISO 4017 M12x60 8-8 A3C		1	
	Screw ISO 4017 M6X70 8.8 A3C	Vis ISO 4017 M6X70 8.8 A3C	Schraube ISO 4017 M6X70 8.8 A3C		1	
	Washer ISO 7089-6	Rondelle ISO 7089-6	Scheibe ISO 7089-6		1	
	Washer DIN 128-6	Rondelle DIN 128-6	Scheibe DIN 128-6		1	
	Nut ISO 4032 M6 N	Ecrou ISO 4032 M6 N	Mutter ISO 4032 M6 N		1	
<b>43</b>	<b>Column base 300 kit</b>	<b>Kit base pour colonne 300</b>	<b>Basis Feld 300 Satz</b>	<b>510136900</b>	<b>1</b>	<b>S</b>
	Column base welded 300	Base soudée pour colonne 300	Feld Basis geschweißt		1	
	Washer DIN 128-8	Rondelle DIN 128-8	Scheibe DIN 128-8		4	
	Washer iso 9021	Rondelle iso 9021	Scheibe iso 9021		4	
	Screw ISO 4017 M8x30 8-8 A3C	Vis ISO 4017 M8x30 8-8 A3C	Schraube ISO 4017 M8x30 8-8 A3C		4	
	<b>Column base 350 kit</b>	<b>Kit base pour colonne 350</b>	<b>Basis Feld 350 Satz</b>	<b>510137004</b>	<b>1</b>	<b>S</b>
	Column base welded 300	Base soudée pour colonne 300	Feld Basis geschweißt		1	
	Washer DIN 128-8	Rondelle DIN 128-8	Scheibe DIN 128-8		4	
	Washer iso 9021	Rondelle iso 9021	Scheibe iso 9021		4	
	Screw ISO 4017 M8x30 8-8 A3C	Vis ISO 4017 M8x30 8-8 A3C	Schraube ISO 4017 M8x30 8-8 A3C		4	
<b>44</b>	<b>Top Beam kit</b>	<b>Kit poutre supérieure</b>	<b>Obere Träger Satz</b>	<b>510136901</b>	<b>1</b>	<b>S</b>
	Spacer Ø18 L=29,4	Entretoise Ø18 L=29,4	Distanzring Ø18 L=29,4		1	
	Gearwheel Z=19 m=1,5	Pignon Z=19 m=1,5	Zahnrad Z=19 m=1,5		2	
	Drive shaft	Arbre de transmission	Gelenkwelle		1	
	Spacer Ø18 L=14	Entretoise Ø18 L=14	Distanzring Ø18 L=14		1	
	Circlip DIN 472 35x1.5	Circlip DIN 472 35x1.5	Sicherungsring DIN 472 35x1.5		2	
	Bearing DIN 625 - 6202-2RS	Palier DIN 625 - 6202-2RS	Lager DIN 625 - 6202-2RS		4	
	Pin slotted ISO 8752 5x14	Goupille fendue ISO 8752 5x14	Stift angebrochen ISO 8752 5x14		2	
	Shim Washer DIN 988 25x35x0.1	Rondelle cale DIN 988 25x35x0.1	Abstützung Scheibe DIN 988 25x35x0.1		3	
	Top Beam machined	Poutre supérieure usinée	Obere Träger bearbeitet		1	
	Screw ISO 4017 M6X70 8.8 A3C	Vis ISO 4017 M6X70 8.8 A3C	Schraube ISO 4017 M6X70 8.8 A3C		2	
	Washer ISO 7089-6	Rondelle ISO 7089-6	Scheibe ISO 7089-6		2	
	Washer DIN 128-6	Rondelle DIN 128-6	Scheibe DIN 128-6		2	
	Nut ISO 4032 M6 N	Ecrou ISO 4032 M6 N	Mutter ISO 4032 M6 N		2	

# Frame / Châssis / Rahmen

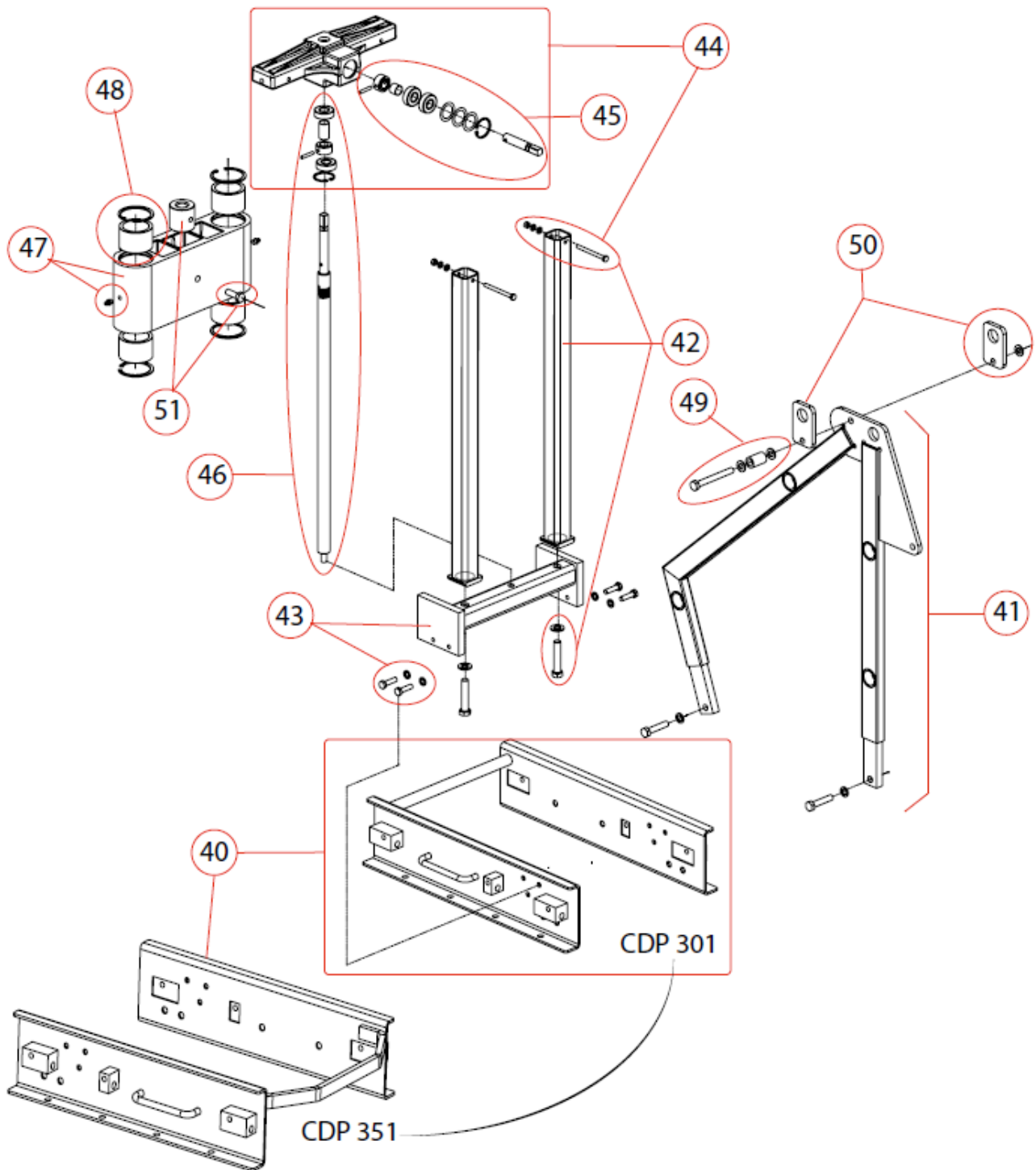

45	Drive shaft kit	Kit arbre de transmission	Gelenkwelle Satz	510136902	1	W
	Gearwheel Z=19 m=1,5	Pignon Z=19 m=1,5	Zahnrad Z=19 m=1,5		1	
	Drive shaft	Arbre de transmission	Gelenkwelle		1	
	Spacer Ø18 L=14	Entretoise Ø18 L=14	Distanzring Ø18 L=14		1	
	Circlip DIN 472 35x1.5	Circlip DIN 472 35x1.5	Sicherungsring DIN 472 35x1.5		1	
	Bearing DIN 625 - 6202-2RS	Palier DIN 625 - 6202-2RS	Lager DIN 625 - 6202-2RS		2	
	Pin slotted ISO 8752 5x14	Goupille fendue ISO 8752 5x14	Stift angebrochen ISO 8752 5x14		1	
	Shim Washer DIN 988 25x35x0.1	Rondelle cale DIN 988 25x35x0.1	Abstützung Scheibe DIN 988 25x35x0.1		3	
46	Endless Screw kit	Kit vis sans fin	Endlosschnecke Satz	510136903	1	W
	Endless Screw with trapezoidal thread - TR 22x5	Vis sans fin à filet trapézoïdal - TR 22x5	Endlosschnecke mit trapezförmig Gewinde - TR 22x5		1	
	Washer Øext 20 Øint 10,5 e=2	Rondelle Øext 20 Øint 10,5 e=2	Scheibe Øext 20 Øint 10,5 e=2		1	
	Spacer Ø18 L=29,4	Entretoise Ø18 L=29,4	Distanzring Ø18 L=29,4		1	
	Circlip DIN 472 35x1.5	Circlip DIN 472 35x1.5	Sicherungsring DIN 472 35x1.5		1	
	Bearing DIN 625 - 6202-2RS	Palier DIN 625 - 6202-2RS	Lager DIN 625 - 6202-2RS		2	
	Pin slotted ISO 8752 5x30	Goupille fendue ISO 8752 5x30	Stift angebrochen ISO 8752 5x30		1	
	Gearwheel Z=19 m=1,5	Pignon Z=19 m=1,5	Zahnrad Z=19 m=1,5		1	
47	Guiding system	Système de guidage	Führungssystem	510136904	1	S
	Molded Guiding structure	Structure de guidage moulée	Führungssystem gegossen		1	
	Screw iso 4029 M8X10	Vis iso 4029 M8X10	Schraube iso 4029 M8X10		4	
	Screw DIN 71412 a M8x1.25 9er 6kt	Vis DIN 71412 a M8x1.25 9er 6kt	Schraube DIN 71412 a M8x1.25 9er 6kt		2	
48	Guiding parts	Elements de guidage	Führungsteilen	510136905	1	W
	Guiding ring	Bagues de guidage	Führungsring		1	
	Circlip DIN 472 -Ø60x2	Circlip DIN 472 -Ø60x2	Sicherungsring DIN 472 - Ø60x2		1	
49	Frame spacer kit 301	Kit entretoise châssis 301	Rahmen 301 distanzring Satz	510136906	1	S
	Spacer Øext 20 Øint 12 L=32	Entretoise Øext 20 Øint 12 L=32	Distanzring Øext 20 Øint 12 L=32		1	
	Screw ISO 4014 M10x70 8-8 A3C	Vis ISO 4014 M10x70 8-8 A3C	Schraube ISO 4014 M10x70 8-8 A3C		1	
	Washer ISO 7089 10N A3C	Rondelle ISO 7089 10N A3C	Scheibe ISO 7089 10N A3C		2	
	Frame spacer kit 351	Kit entretoise châssis 351	Rahmen 351 distanzring Satz	510137005	1	S
	Spacer Øext 20 Øint 12 L=57	Entretoise Øext 20 Øint 12 L=57	Distanzring Øext 20 Øint 12 L=57		1	
	Screw ISO 4014 M10x90 8-8 A3C	Vis ISO 4014 M10x90 8-8 A3C	Schraube ISO 4014 M10x90 8-8 A3C		1	
	Washer ISO 7089 10N A3C	Rondelle ISO 7089 10N A3C	Scheibe ISO 7089 10N A3C		2	
50	Hubplate kit	Kit platine de levage	Hebenplatin Satz	510136907	1	S
	Hubplate	Platine	Platin		2	
	Washer ISO 7089 10N A3C	Rondelle ISO 7089 10N A3C	Scheibe ISO 7089 10N A3C		1	
51	Endless screw nut	Ecrou vis sans fin	Endlosschnecke Mutter	510136908	1	W
	Special brass nut Øext 45 trou M10 H=44 TRM22x5	Ecrou spécial en laiton Øext 45 trou M10 H=44 TRM22x5	Spezifisch Messing Mutter Øext 45 trou M10 H=44 TRM22x5		1	
	Screw ISO 4017 M10x30 8-8 A3C	Vis ISO 4017 M10x30 8-8 A3C	Schraube ISO 4017 M10x30 8-8 A3C		2	
	Washer din 125 M10	Rondelle din 125 M10	Scheibe din 125 M10		2	
	Washer din 127 M10	Rondelle din 127 M10	Scheibe din127 M10		2	

# Engine support / Support moteur / Motor Träger

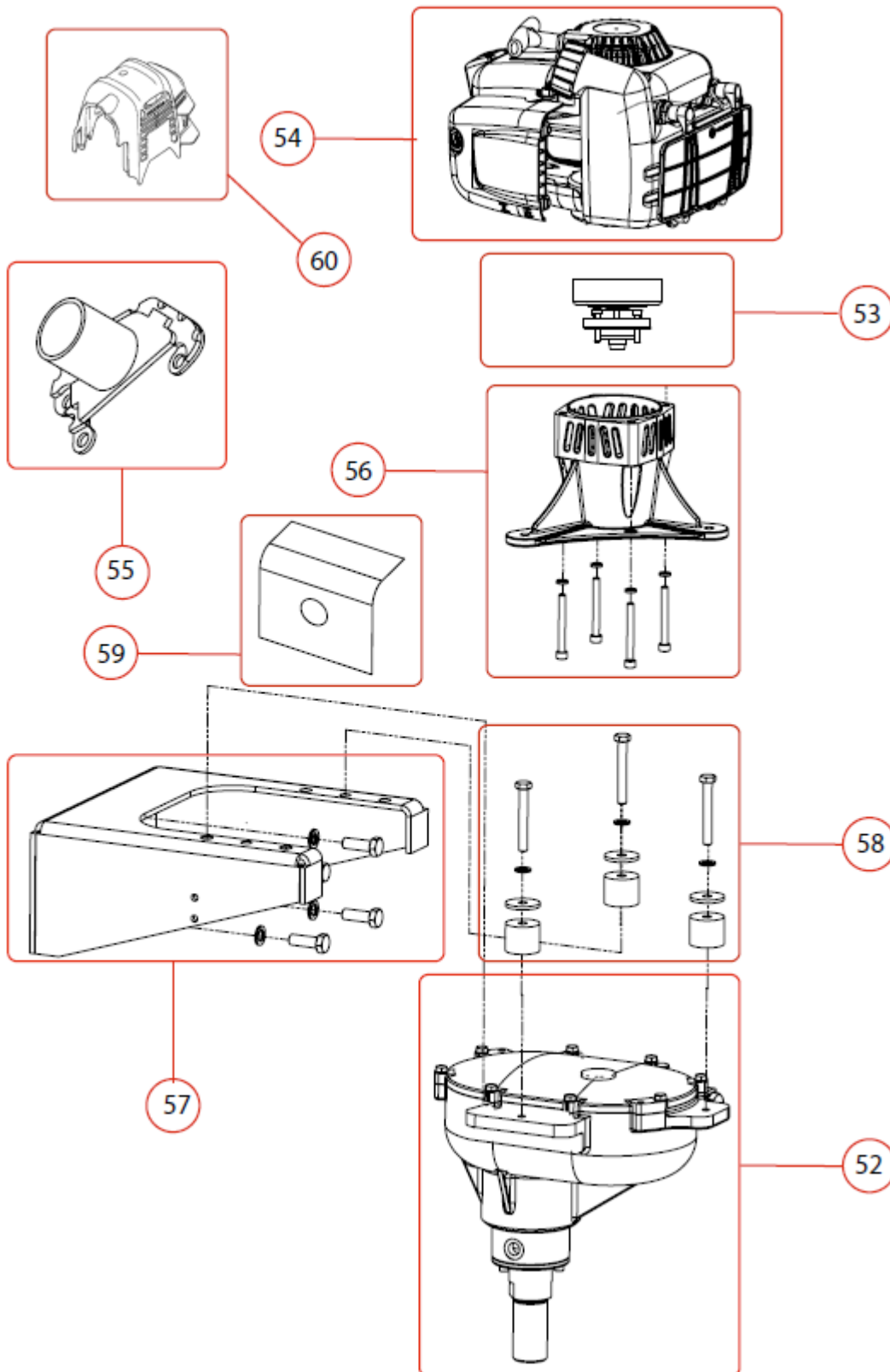

POS	DESCRIPTION EN	DESCRIPTION FR	BESCHREIBUNG	REF	QTY	TYP
52	Gearbox ROBO assy.	Boîte de vitesse ROBO compl.	ROBO Getriebe kompl.	510136909	1	S
53	Engine coupling	Accouplement moteur	Motorkupplung	310464882	1	W
54	Engine assy.	Moteur compl.	Motor kompl.	310531346	1	S
55	Interface motor-exhaust kit	Kit interface moteur-pot d'échappement	Motor-Auspuff Schnittstelle Satz	310537625	1	S
56	Motor base kit	Kit base moteur	Motor Basis Satz	510136993	1	S
	Molded base motor	Base moteur moulé	Motor Basis gegossen		1	
	Screw ISO 4762 M6x55 - 24N	Vis ISO 4762 M6x55 - 24N	Schraube ISO 4762 M6x55 - 24N		4	
57	Support motor kit	Kit support moteur	Motor Träger Satz	510136995	1	S
	Motor support welded	Support moteur soudé	Motor Träger geschweißt		1	
	Washer DIN 127 M10	Rondelle DIN 127 M10	Scheibe DIN 127 M10		4	
	Screw ISO 4017 M10x30 - AB	Vis ISO 4017 M10x30 - AB	Schraube ISO 4017 M10x30 - AB		4	
58	Spacer motor support kit	Kit entretoise support moteur	Distanzring Motorträger Satz	510136992	1	W
	Screw ISO 4014 M8x60 AB	Vis ISO 4014 M8x60 AB	Schraube ISO 4014 M8x60 AB		3	
	Washer DIN 128 - A8	Rondelle DIN 128 - A8	Scheibe DIN 128 - A8		3	
	Motor support spacer Øext 32 Øint 8 L=26	Entretoises support moteur Øext 32 Øint 8 L=26	Motorträger distanzring Øext 32 Øint 8 L=26		3	
	Rubber Washer Øext 32 Øint 8 e=3	Rondelles caoutchouc Øext 32 Øint 8 e=3	Gummischeiben Øext 32 Øint 8 e=3		3	
	Washer DIN 9021 M10	Rondelle DIN 9021 M10	Scheibe DIN 9021 M10		4	
59	Grid	grille	Gitter	310537707	1	W
60	Motor cover	Carter moteur	Kurbelgehäuse	310537706	1	W

Engine parts / pièces moteur / Motor teil

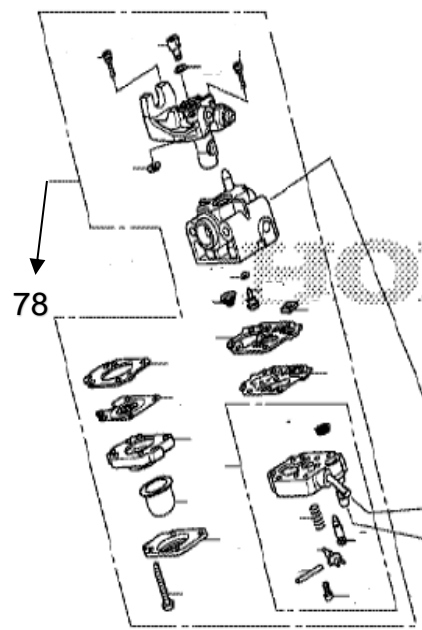
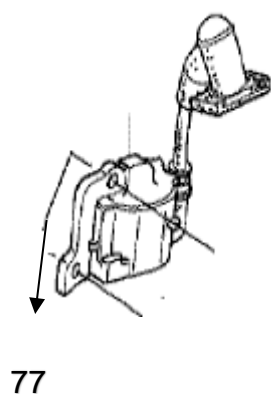
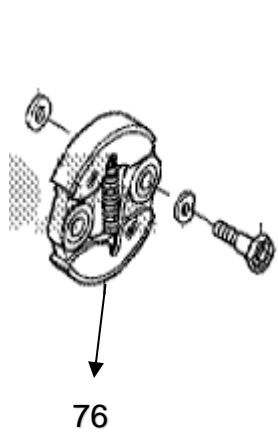
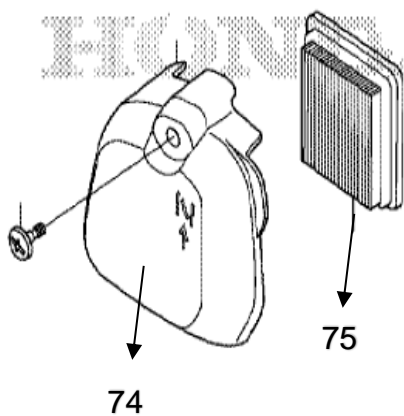
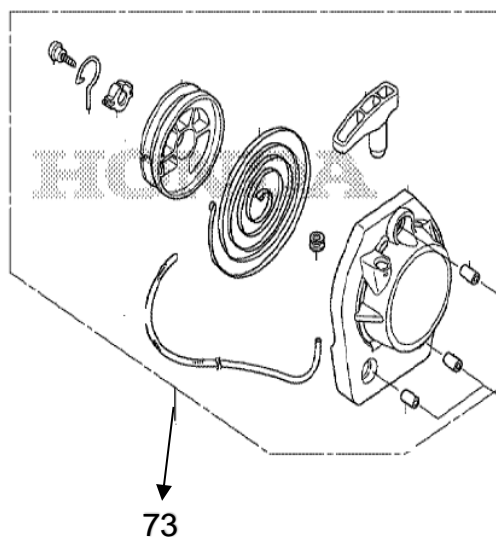

POS	DESCRIPTION EN	DESCRIPTION FR	BESCHREIBUNG	REF	QTY	TYP
73	Pull cord	lanceur	startgerat	310545400	1	s
74	Air filter cover	couvercle de filtre à air	Luftfilter kapp	310545404	1	s
75	Air filter	element de filtre à air	luftfilter	310545403	1	s
76	clutch	embrayage	kupplung	310545401	1	s
77	Ignition coll	ens. bobine d'allumage	zundspule	310545405	1	s
78	carburetor	carbureteur	vergaser	310545402	1	s
	Spark plug	bougie	zundkerze	310545407	1	s

## Engine accessory / Accessoires moteur KP/ Motor KP Zubehör

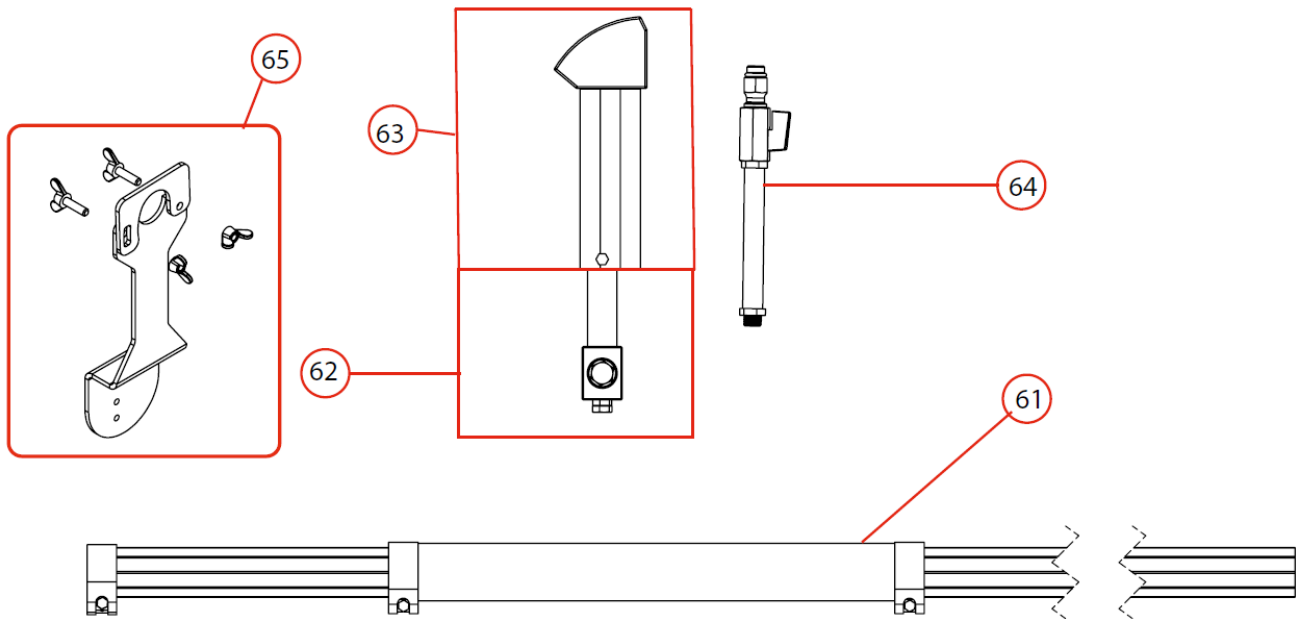

POS	DESCRIPTION EN	DESCRIPTION FR	BESCHREIBUNG	REF	QTY	TYP
61	Exhaust pipe assy.	Pot d'échappement compl.	Auspuff kompl.	510136894	1	W
	Thermal protection	Gaine thermique	Wärmeschutz		1	
	Exhaust pipe	Tube d'échappement	Auspuffrohr		1	
	Clamp	Collier	Klemme		2	
	Clamp	Collier	Klemme		2	
62	Gas handle support Ø25	Support poignée accélérateur Ø25	Gasgriff Träger Ø25	310546619	1	S
62	Gas handle support Ø19	Support poignée accélérateur Ø19	Gasgriff Träger Ø19	310578973	1	S
	Pipe assy.	Tube assemblé	Rohr Montage		1	
	Handle base	Support poignée	Griff Träger		1	
	Screw ISO 4017 - M8x16 - N	Vis ISO 4017 - M8x16 - N	Schraube ISO 4017 - M8x16 - N		1	
	Screw ISO 4036 - M8 - N	Vis ISO 4036 - M8 - N	Schraube ISO 4036 - M8 - N		1	
	Screw ISO 4014 M10x60	Vis ISO 4014 M10x60	Schraube ISO 4014 M10x60		1	
	Washer ISO 7089 - 10N - A3C	Rondelle ISO 7089 - 10N - A3C	Scheibe ISO 7089 - 10N - A3C		1	
63	Throttle Ø25	Poignee Ø25	Griff Ø25	310546617	1	S
63	Throttle Ø19	Poignee Ø19	Griff Ø19	310578972	1	S
64	Water hose	Tuyau d'eau	Wasserschlauch	510113510	1	S
65	Exhaust pipe support	Support pot d'échappement	Auspuff träger	310537624	1	S

# Accessory / Accessoires / Zubehör

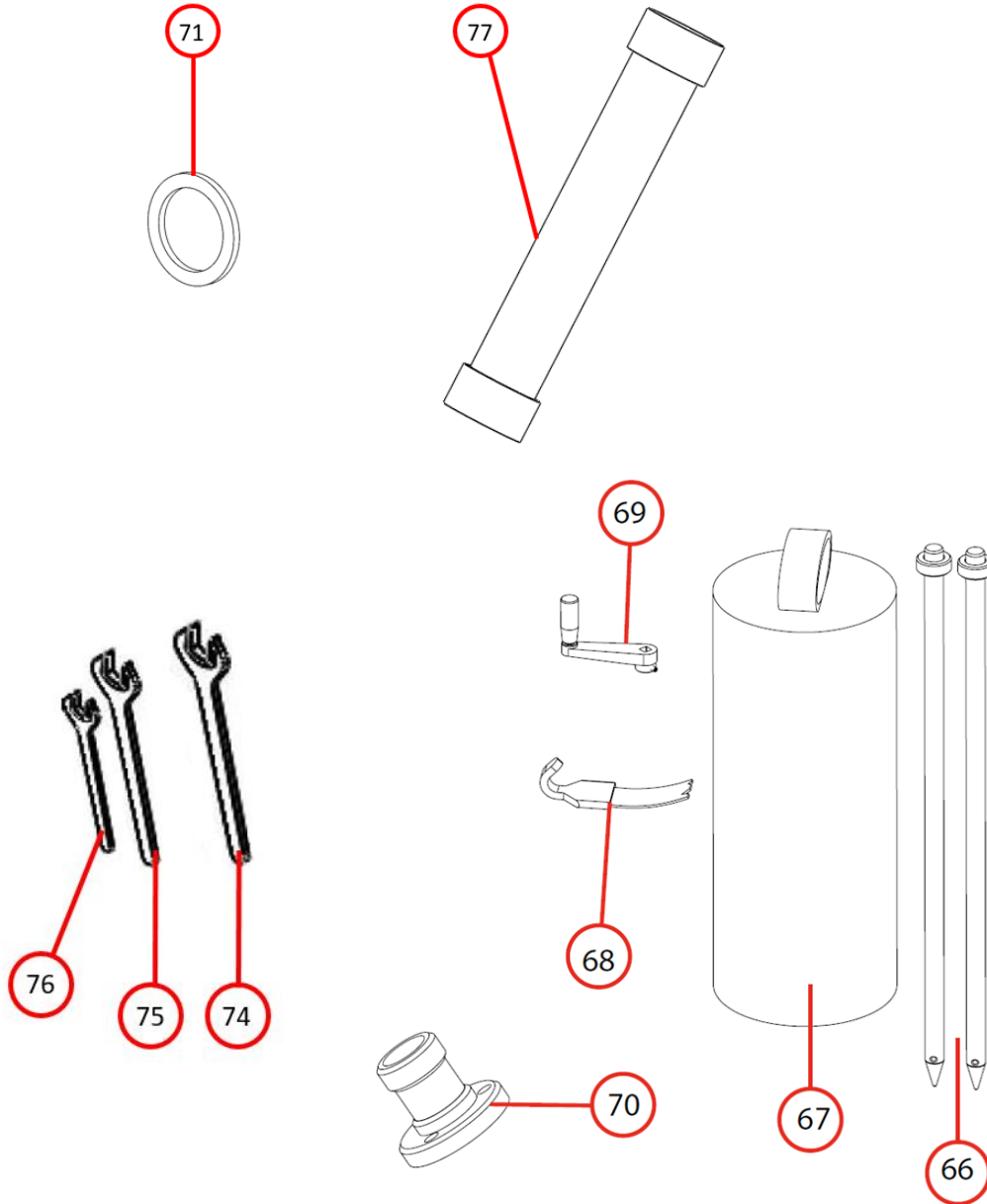

POS	DESCRIPTION EN	DESCRIPTION FR	BESCHREIBUNG	REF	QTY	TYP
66	Anchoring spike kit	Kit pic d'amarrage	Befestigungspik Satz	510136997	1	W
	Anchoring spike head	Tête de pic d'amarrage	Befestigungspik Kopf		2	
	Anchoring spike	Pic d'amarrage	Befestigungspik		2	
67	11 L Pressure water Tank	Réservoir d'eau 11 L	Wassertank 11 L	310521698	1	S
68	Strap	Sangle	Gurt	510136998	1	W
69	Drive shaft handle	Manivelle arbre de transmission	Gelenkwelle Kurbel	510136999	1	S
70	Adapter flange kit	Kit adaptateur flasque	Flansch Adapter Satz	310004594	1	W
	Adapter 1 "1/4 for 3-hole flange	Adaptateur 1"1/4 pour flasque à 3 trous	Adapter 1"1/4 für Flansch mit 3 Lohr		1	
	Screw DIN 912 M10x16	Vis DIN 912 M10x16	Schraube DIN 912 M10x16		3	
	Washer DIN 127 Ø10	Rondelle frein DIN 127 Ø10	Scheibe DIN 127 Ø10		3	
74	Wrench 41mm	Clé 41mm	Maulschlüssel 41mm	310006482	1	S
75	Wrench 36mm	Clé 36mm	Maulschlüssel 36mm	310004177	1	S
76	Wrench 17mm	Clé 17mm	Maulschlüssel 17mm	310004229	1	S
77	Manual Plastic Bag	Tube Plastique Manuel	Kunststoffrohr Anleitung	510081348	1	S
71	Bronze ring	Bague en bronze	Bronzenring	310004317	1	S

Stickers 351 / Autocollants 351/ Aufkleber 351



72

POS	DESCRIPTION EN	DESCRIPTION FR	BESCHREIBUNG	REF	QTY	TYP
72	Stickers kit 351	Kit autocollants 351	Aufkleber Satz 351	310537699	1	S
	Risk of feet cut	Risque de coupure pieds	Risiko von Schnittfüße		1	
	Pictograms CE	Pictogrammes CE	CE Piktogramme		1	
	Sticker CDP 351 left side	Sticker gauche CDP 351	Links CDP 351 Aufkleber		1	
	Sticker CDP 351 right side	Sticker droit CDP 351	Rechte CDP 351 Aufkleber		1	
	Norton bands	Bandes bleues Norton	Norton Bänder Aufkleber		1	
	Sticker Norton Clipper	Autocollant Norton Clipper	Norton Clipper Aufkleber		1	

Stickers 301 / Autocollants 301/ Aufkleber 301



73

POS	DESCRIPTION EN	DESCRIPTION FR	BESCHREIBUNG	REF	QTY	TYP
73	Stickers kit 301	Kit autocollants 301	Aufkleber Satz 301	310537698	1	S
	Risk of feet cut	Risque de coupure pieds	Risiko von Schnittfüße		1	
	Pictograms CE	Pictogrammes CE	CE Piktogramme		1	
	Sticker CDP 301 left side	Sticker gauche CDP 301	Links CDP 301 Aufkleber		1	
	Sticker CDP 301 right side	Sticker droit CDP 301	Rechte CDP 301 Aufkleber		1	
	Norton bands	Bandes bleues Norton	Norton Bänder Aufkleber		1	
	Sticker Norton Clipper	Autocollant Norton Clipper	Norton Clipper Aufkleber		1	

SAINT-GOBAIN ABRASIVES  
 INDUSTRIEWEG 21  
 9420 ERPE-MERE  
 BELGIUM  
 TEL: +32(0) 2 267 21 00

SAINT-GOBAIN ABRASIVES, S.R.O.  
 POČERNICKÁ 272/96, MALEŠICE  
 108 00 PRAHA 10  
 CZECH REPUBLIC  
 TEL: +420 255 719 326  
 FAX: +420 255 719 321

SAINT-GOBAIN ABRASIVES A/S  
 DYBENDALSVEJENGET 2,  
 DK-2630 TAASTRUP  
 DENMARK  
 TEL: +45 4675 5244

PO BOX 643706  
 FORTUNE TOWER OFFICE 2106  
 JLT BLOCK C  
 (NEXT TO METRO STATION)  
 JUMEIRA LAKE TOWER, DUBAI  
 UNITED ARAB EMIRATES  
 TEL: +971 4 431 5154  
 FAX: +971 4 431 5434

SAINT-GOBAIN ABRASIFS  
 RUE DE L'AMBASSADEUR - B.P.8  
 78 702 CONFLANS CEDEX  
 FRANCE  
 TEL: +33 (0)1 34 90 40 00  
 FAX: +33 (0)1 39 19 89 56

SAINT-GOBAIN ABRASIVES GMBH  
 BIRKENSTRASSE 45-49  
 D-50389 WESSELING  
 GERMANY  
 TEL: +49 (0) 2236 703-1  
 +49 (0) 2236 8996-0  
 +49 (0) 2236 8911-0  
 FAX: +49 (0) 2236 703-367  
 +49 (0) 2236 8996-10  
 +49 (0) 2236 8911-30

FÜR DEN FACHHANDEL  
 ÖSTERREICH  
 TEL: +43 (00) 662 430 076

SAINT-GOBAIN ABRASIVES KFT.  
 1225 BUDAPEST  
 BÁNYALÉG U. 60/B.  
 HUNGARY  
 TEL: +36 1 371 22 50  
 FAX: +36 1 371 22 55

SAINT-GOBAIN ABRASIVI S.P.A  
 VIA PER CESANO BOSCONI 4  
 I-20094 CORSICO MILANO  
 ITALY  
 TEL: +39 02 44 851  
 FAX: +39 02 44 78 266

SAINT-GOBAIN ABRASIVES S.A.  
 190 RUE J.F. KENNEDY  
 L-4930 BASCHARAGE  
 GRAND DUCHE DE LUXEMBOURG  
 TEL: +352 50 401 1  
 FAX: +331 83 717 792  
 NO. VERT (FRANCE): 0800 906 903

SAINT-GOBAIN ABRASIFS, S.A.  
 2 ALLÉE DES FIGUIERS  
 AIN SEBAÂ - CASABLANCA  
 MOROCCO  
 TEL: +212 5 22 66 57 31  
 FAX: +212 5 22 35 09 65

SAINT-GOBAIN ABRASIVES BV  
 GROENLOSEWEG 28  
 7151 HW EIBERGEN  
 P.O. BOX 10  
 7150 AA EIBERGEN  
 THE NETHERLANDS  
 TEL: +31 545 466466  
 FAX: +31 545 474605

SAINT-GOBAIN ABRASIVES AS  
 POSTBOKS 11, ALNABRU,  
 0614 OSLO  
 BROBEKKVEIEN 84,  
 0582 OSLO  
 NORWAY  
 TEL: +47 63 87 06 00  
 FAX: +47 63 87 06 01

SAINT-GOBAIN HPM POLSKA SP. Z O.O.  
 UL. NORTON I  
 62-600 KOŁO  
 POLAND  
 TEL: +48 63 26 17 100  
 FAX: +48 63 27 20 401

SAINT-GOBAIN ABRASIVOS, L. DA  
 ZONA INDUSTRIAL DA MAIA  
 I-SECTOR VIII, NO. 122  
 APARTADO 6050  
 4476 - 908 MAIA  
 PORTUGAL  
 TEL: +351 229 437 940  
 FAX: +351 229 437 949

SAINT-GOBAIN GLASS  
 BUSINESS UNIT ABRASIVI  
 PUNCT DE LUCRU: LOC.VETIS,JUD.  
 SATU MARE 447355  
 STR. CAREIULUI 11  
 PARC INDUSTRIAL RENOVATIO  
 ROMANIA  
 TEL: +40 261 839 709  
 FAX: +40 261 839 710

SG HPM RUS  
 58, F. ENGELS STR.  
 STROENIE 2  
 105082 MOSCOW  
 RUSSIA  
 TEL: +74 955 408 355  
 FAX: +74 959 373 224

SAINT-GOBAIN  
 ABRASIVES (PTY) LTD  
 2 MONTEER ROAD  
 ISANDO 1600  
 P.O. BOX 67  
 SOUTH AFRICA  
 TEL: +27 11 961 2000  
 FAX: +27 11 961 2184/5

SAINT-GOBAIN ABRASIVOS, S.A.  
 CTRA. DE GUIPÚZCOA, KM. 7,5  
 E-31195 BERRIOPLANO (NAVARRA)  
 SPAIN  
 TEL: +34 948 306 000  
 FAX: +34 948 306 042

SAINT GOBAIN ABRASIVES AB  
 GÅRDSFOGDEVÄGEN 18A  
 168 66 BROMMA • SVERIGE  
 SWEDEN  
 TEL: +46 8 580 881 00  
 FAX: +46 8 580 881 30

SAINT-GOBAIN INOVATIF MALZEMELER  
 VE ASINDIRICI SAN. TIC. AS.  
 ALTAYÇEŞME MAH. ÇAMLI SOK. NO:21  
 ESAS OFISPARK KAT:9 34843  
 MALTEPE, İSTANBUL  
 TURKEY  
 TEL: 0090-216-217 12 50  
 FAX: 0090-216-442 40 74

SAINT-GOBAIN ABRASIVES LTD.  
 DOXEY RD  
 STAFFORD  
 ST16 1EA  
 UNITED KINGDOM  
 TEL: +44 1785 222 000  
 FAX: +44 1785 213 487



Saint-Gobain Abrasifs  
 190 Rue J.F. Kennedy  
 L-4930 Bascharage  
 Grand Duche de Luxembourg  
 Tel: +331 83 717 792  
 Fax: +352 50 16 33  
 no. vert (France) 0800 906 903