

CS 901 D25

OPERATING INSTRUCTIONS

Translation of the original instructions



SAINT-GOBAIN

clipper[®]



CE Declaration of conformity

The undersigned manufacturer:

**SAINT - GOBAIN ABRASIVES S.A.
190, BD. J. F. KENNEDY
L-4930 BASCHARAGE**

Declares that this product:

« Floor saw »: **CS 901 D25**

Code : **70184632648**

is in conformity with the following Directives :

- **"MACHINES" 2006/42/CE**
- **"NOISE" 2000/14/CE**

And the European standard:

- **EN 13862 – Floor cutting-off machines – Safety**

Valid for machines as of serial number:

450XXXXXXX

Storage site for the technical documents:

Saint-Gobain Abrasives 190, Bd. J. F. Kennedy 4930 BASCHARAGE, LUXEMBOURG

This declaration of conformity loses its validity when the product is converted or modified without agreement.

Bascharage, 02/03/2023.

François Chianese, executive officer and responsible for the technical file.
Bascharage, Luxembourg



The undersigned manufacturer:

SAINT - GOBAIN ABRASIVES S.A.
190, BD J.F. KENNEDY
L- 4930 BASCHARAGE

Declares that this product:

Floor Saw: **CS 901 D25**

Code: **70184632648**

is in conformity with the following standard:

- ***Supply of Machinery (Safety) Regulations 2008***
- ***Noise Emission in the Environment by Equipment for use Outdoors Regulations 2001***

and European standard:

- ***EN 13862 – Floor cutting-off machines – Safety***

Valid for machines with a serial number greater than: 450XXXXXXX

Authorised Representative:

SAINT-GOBAIN ABRASIVES

Unicorn House • Unit 1, Amison Close

Redhill Business Park • Stafford • England • ST16 1WB

This declaration of conformity loses its validity when the product is converted or modified without agreement.

Bascharage, 02.03.2023

François Chianese, executive officer and responsible for the technical file.
Bascharage, Luxembourg

CS 901 OPERATING INSTRUCTIONS

1	BASIC SAFETY INSTRUCTIONS	6
1.1	<i>Symbols</i>	6
1.2	<i>Machine plate</i>	8
1.3	<i>Safety instructions for particular operating phases</i>	8
1.4	<i>Environmental protection</i>	9
2	GENERAL DESCRIPTION OF THE CS 901	10
2.1	<i>Short description</i>	10
2.2	<i>Layout</i>	10
2.3	<i>Technical data</i>	13
2.4	<i>Statement regarding the vibration emission</i>	14
2.5	<i>Statement regarding noise emission</i>	15
3	ASSEMBLY AND COMMISSIONING	16
3.1	<i>Setting the operating position</i>	16
3.2	<i>Setting the lowering speed</i>	16
3.3	<i>Refueling</i>	17
3.4	<i>Tool assembly</i>	18
3.5	<i>Changing from right to left cut</i>	19
3.6	<i>Widening the blade holder</i>	19
3.7	<i>Water cooling system</i>	20
3.8	<i>Starting and switching off the machine</i>	21
4	OPERATING THE CS 901	22
4.1	<i>Site of work</i>	22
4.2	<i>Cutting method</i>	22
4.3	<i>Cutting with the blade guard opened</i>	24
4.4	<i>Setting toe in</i>	24
5	TRANSPORT AND STORING	25
5.1	<i>Moving the CS 901</i>	25
5.2	<i>Transport position</i>	26
5.3	<i>Relocating using a crane</i>	27
5.4	<i>Securing the machine for transport</i>	28
5.5	<i>Machine storage</i>	28
5.6	<i>Disposal</i>	28
6	MAINTENANCE AND SERVICE	29
6.1	<i>Maintenance of the machine</i>	29
6.2	<i>Maintenance of the engine</i>	34
7	BREAKDOWNS: CAUSES AND CURES	36
7.1	<i>Breakdown-finding procedures</i>	36
7.2	<i>Warning lights</i>	36
7.3	<i>Trouble-shooting guide</i>	37
7.4	<i>Circuit diagram</i>	38
7.5	<i>Customer service</i>	41
7.6	<i>Spare parts</i>	42

1 BASIC SAFETY INSTRUCTIONS

The CS 901 is exclusively designed for the cutting of floors made of asphalt, green and cured concrete (reinforced or not) as well as of industrial cement.

Uses other than the manufacturer's instructions shall be considered as contravening the regulations. The manufacturer shall not be held responsible for any resulting damage. Any risk shall be borne entirely by the user. Observing the operating instructions and compliance with inspection and servicing requirements shall also be considered as included under use in accordance with the regulations.

1.1 Symbols

Important warnings and pieces of advice are indicated on the machine using symbols. The following symbols are used on the machine:



Read the operating manual



Wear hearing protection



Wear eye protection



Wear gloves



Wear protective helmet



Wear dust mask



Wear suitable work clothing



Attachment points for crane transport



Remove the ignition key before working on the device



Cutting hazard at the rotating tool



Do not relocate the machine with rotating tool



Extremely flammable fuel vapours



Risk of crushing due to unintentional movement



Danger due to ejected parts



Danger due to suspended loads



Hot surfaces. Contact can cause burns



Danger of suffocation due to toxic gases



Danger due to battery acid



Explosion hazard



Danger of drawing in due to open belt drive



Risk of cutting injuries and amputation due to rotating cutting tools



Do not use high pressure cleaners



No unauthorised persons allowed



Smoking prohibition



Harmful substances: Fine silica dust



No maintenance activities allowed when the engine is running



Instruction for damage prevention.



Lashing point for vehicle transport



Sound-power level of the machine

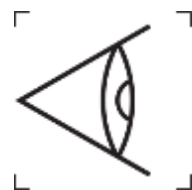

Visual inspection

1.2 Machine plate

Important data can be found on the following plate located on the machine:



1.3 Safety instructions for particular operating phases

Before commencing work

- Before commencing work, make yourself familiar with the working environment at the place of use. The working environment includes: obstacles in the area of work and manoeuvre, the firmness of the floor, necessary protection at the site relating to public thoroughfares and the availability of help in the event of accidents.
- Check for correct mounting of the blade regularly.
- Immediately remove damaged or badly worn blades, as they endanger the operator whilst rotating.
- Always cut with the blade guard in position.
- Only fit NORTON diamond blades to the machine! The use of other tools can damage the machine!
- Read the blades' specifications carefully to choose the correct tool for your application.
- Attention is drawn to the use of BS2092 safety goggles in conformity with specified Processes No.8 of the Protection of Eyes Regulation 1974, Regulation 2(2) Part 1. Also use the other safety equipment as mentioned in the symbols plus a dust mask when dry cutting is applied.
- For security reasons, never leave the machine unattended, untied or unlocked.

While the engine is running

- Do not move the machine whilst the blade is running idle.
- Do not run the machine without the security guards in place.
- Apply cooling water continuously whilst cutting !

Petrol powered machines:

- Always use the fuel advised.
- In confined areas, exhaust gases should be evacuated and the job site properly aerated.
- Petrol and diesel machines, which by their nature emit toxic exhaust gases, must not be used in places prohibited by the Health at Work etc. Act 1974 or which are prohibited by Factory Inspectors or Safety Officers.
- Fuel is flammable. Before filling the tank, shut down the engine, extinguish all open flames and do not smoke. Take care that no petrol is spilled on any motor part. Always wipe up spilled fuel.

1.4 Environmental protection

Packaging material, cleaning agents, used or remaining operating supplies, and unwrapped wear parts, such as drive belts or engine oils, must be recycled in accordance with local environmental regulations.

2 GENERAL DESCRIPTION OF THE CS 901

Any modification, which could lead to a change in the original characteristics of the machine, may be done only by Saint-Gobain Abrasives S.A. who shall confirm that the machine is still in conformity with the safety regulations. Saint-Gobain Abrasives S.A. keeps the right of making technical or design modification without prior notification.

2.1 Short description

The **Floor Saw CS 901** you have chosen is used for small repair works in concrete and asphalt, for cutting and installing cables as well as for cutting expansion joints. It can be used either for wet cutting operations.

All component parts on the **CS 901** are assembled to a high quality standard, ensuring long life, reliability and a minimum of maintenance. The floor saw enables precise and straight sawing thanks to its extremely low center of gravity and adjustable rear axle.

The lifting or lowering of the blade, ensured by an electro-hydraulic control, as well as the height-adjustable handles make it a very ergonomic machine.

Special types of blades are available for asphalt, green concrete, cured concrete (reinforced or not) as well as for industrial cement flooring.

2.2 Layout

2.2.1 Names of the machine parts

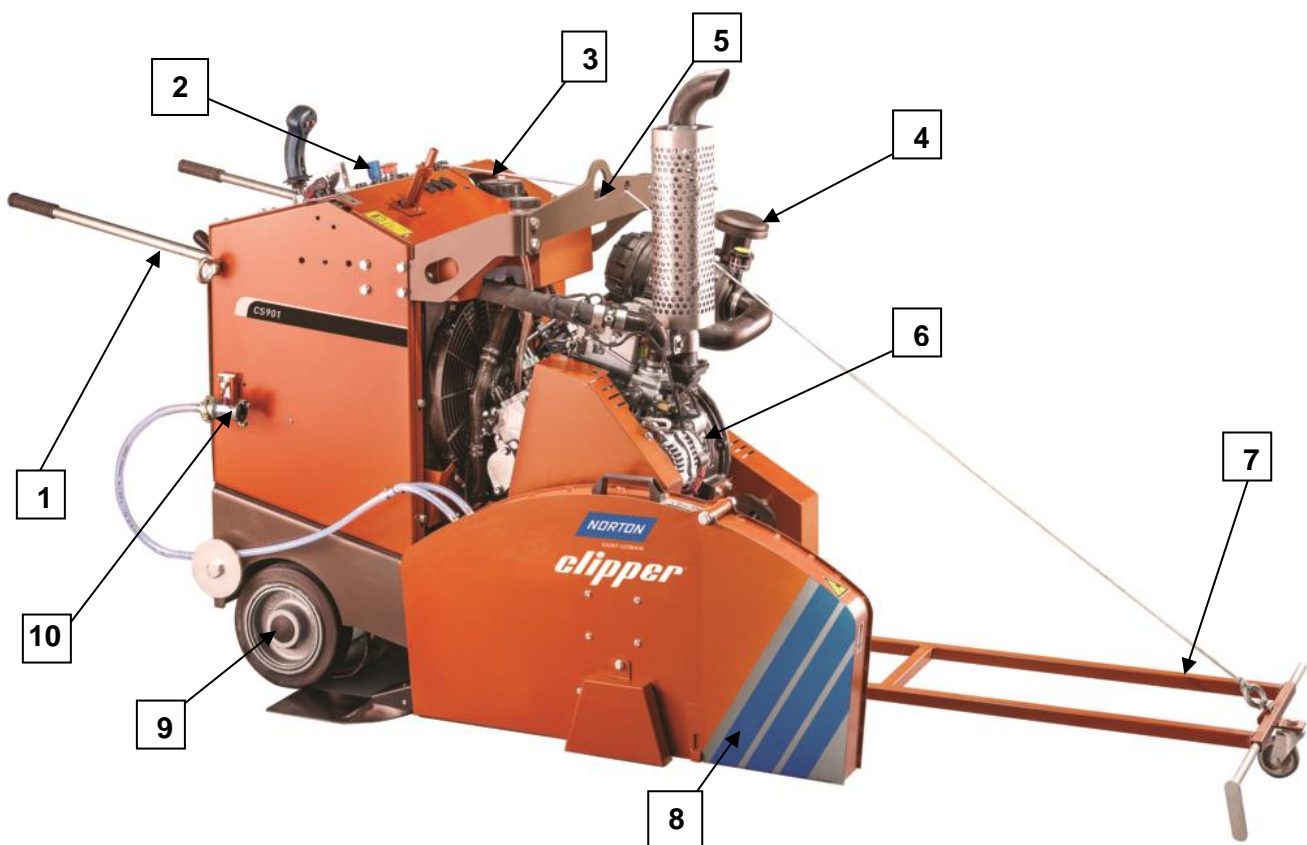

Pos.1	Handlebars	Pos.6	Diesel engine
Pos.2	Control panel	Pos.7	Steering rod
Pos.3	Diesel tank	Pos.8	Blade guard
Pos.4	Air filter	Pos.9	Drive axle (hydrostat)
Pos.5	Hitch point for the crane, manual transmission	Pos.10	Water connection with ball valve

2.2.2 Back and interior

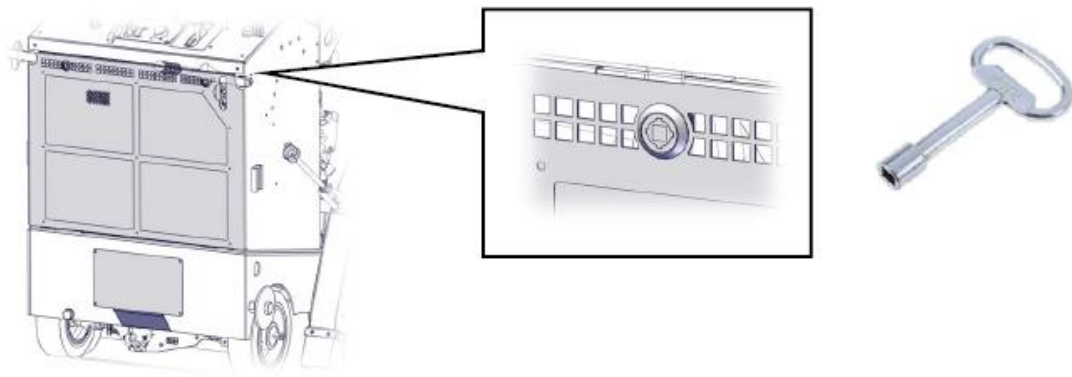

To open the back panel, unlock the back wall at the top with a square key and open out downwards.

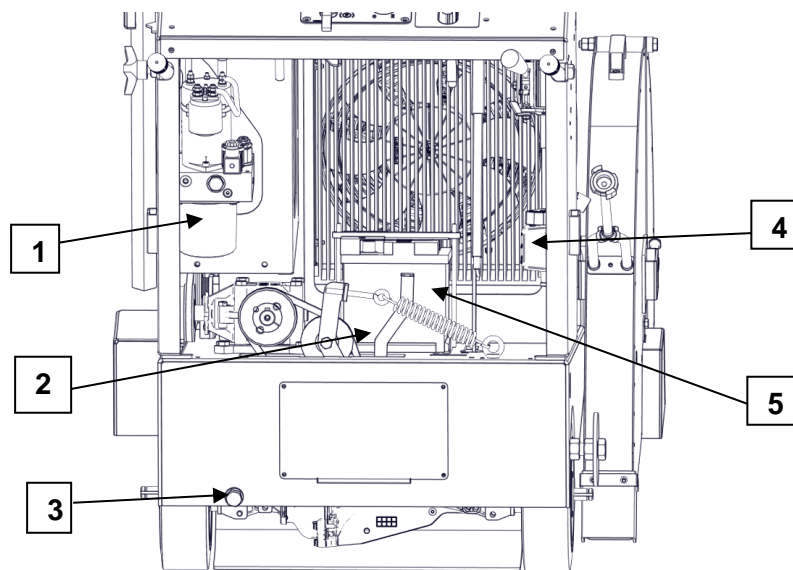

Pos.1	Pump and reservoir for hydraulic unit for saw blade lifting (HV68)	Pos.4	Hydrostat-gear oil reservoir (20W50)
Pos.2	Drive/freewheel selector lever	Pos.5	Battery
Pos.3	Parallelism adjustment screw		

The correct hydraulic oil level can only be read when the machine is completely lowered.

2.2.3 Control panel

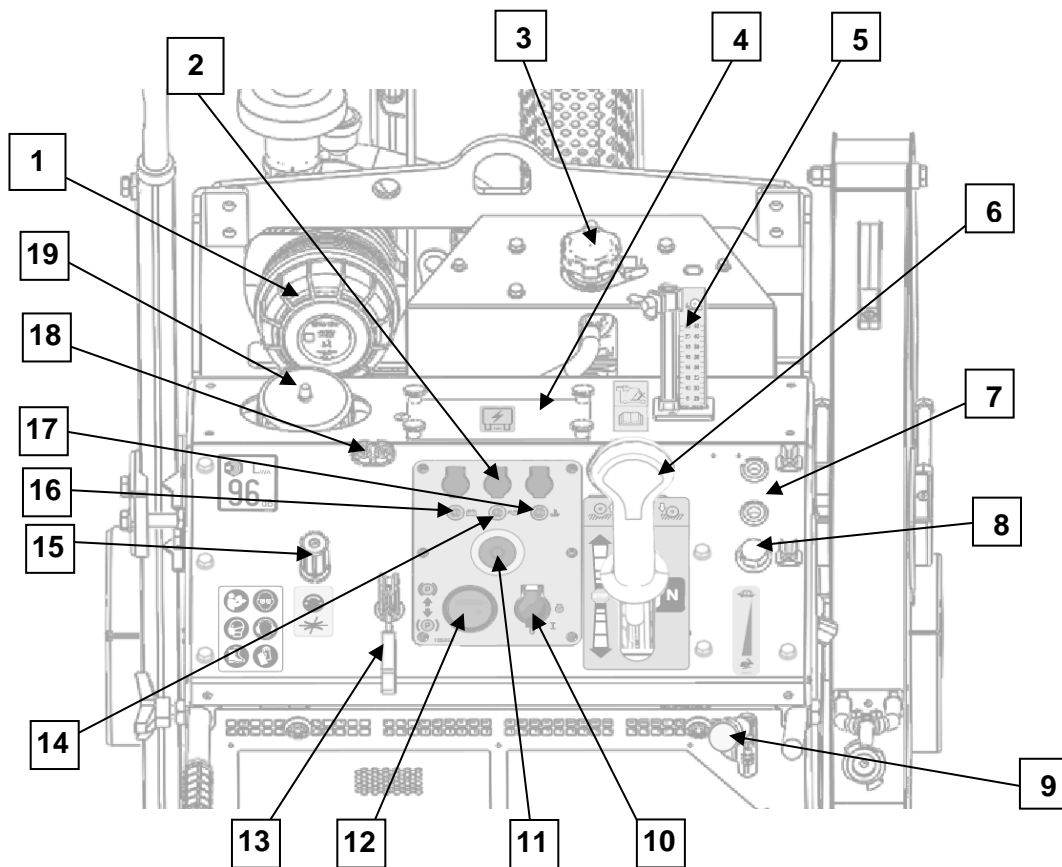

Pos.1	Fuel tank	Pos.11	Emergency stop
Pos.2	Power connection DC 12V (max 10A)	Pos.12	Operating hours counter
Pos.3	Engine coolant filler neck	Pos.13	Parking brake
Pos.4	Fuse compartment	Pos.14	Warning light oil pressure
Pos.5	Cutting depth indicator	Pos.15	Throttle for lowering speed
Pos.6	Combi control lever feed and lift shear	Pos.16	Warning light alternator
Pos.7	On-board tool kit	Pos.17	Water temperature warning light
Pos.8	Extractor tool	Pos.18	Clamping block for dipstick cable
Pos.9	Engine speed adjuster	Pos.19	Diesel fuel cap
Pos.10	Ignition		

Emergency stop mushroom button is an emergency stop device and must not be used as an off switch. Use the ignition key to switch off the machine.

2.3 Technical data

Engine	3-cylinder PERKINS 25HP (18,4kW) EU Stage V / EPA Tier 4 final
Fuel	Diesel ULSD
Oil	SAE 10W-40 recommended Only engine oil approved by the manufacturer API CK4, ACEA E9 or EFC-3 or better may be used.
Starter	Electric
Cooling	Water cooling Perkins ELC allows 6000 operating hours (3 years).
Advance	Automatic
Lifting and lowering	Electrohydraulic
Max. blade diameter	900 mm
Blade bore	25,4 mm
Max. cutting depth mm	365 mm
Flange diameter	150 mm
Blade shaft speed	1490 min ⁻¹
Fuel tank	20 ltrs
Machine dimensions (length x width x height)	1300 x 850 x 1350 mm
Weight	458 kg
Sound pressure level	92 dB (A) (ISO EN 11201)
Sound energy level	96 dB (A) (ISO EN 3744)
Vibration emission value	2.5 m/s ² (EN 12096)

2.4 Statement regarding the vibration emission

Declared vibration emission value in accordance with **EN 12096**

Machine Model / code	Measured vibration emission value a m/s²	Uncertainty K m/s²	Tool used Model / code
CS 901 D25 70184632648	2.5	0.5	Maximum saw blade diameter Ø1000

- Values determined according to procedure described in annex F of **EN 13862**
- Measurements are made with new machines. Real values in the field could vary the simple one with the double according to operating conditions, depending on:
 - Material
 - Cutting depth
 - Machine wear
 - Lack of maintenance
 - Tool not adapted to application
 - Tool in bad shape
 - Non-specialised operator
- Vibrations exposure time depends on cutting performance too (adaptation machine / tool / material / operator)
- When evaluating risks due to hand-arm vibration, you need to take into account effective usage at rated power of machine during a full day of work; quite often you will realise that effective utilisation time represents around 50% of overall duration of work. You have to consider, of course, breaks, water feeding, preparation of work, time to move the machine, disk mounting...

2.5 Statement regarding noise emission

Declared value of noise emission following **EN ISO 11201** and **NF EN ISO 3744**.

Machine Model / code	Sound Pressure level L_{Peq} EN ISO 11201	Uncertainty K (Sound Pressure level L_{Peq} EN ISO 11201)	Sound power level L_{Weq} NF EN ISO 3744	Uncertainty K (Sound power level L_{Weq} NF EN ISO 3744)
CS 901 D25 70184632648	92 dB(A)	2.5 dB(A)	96 dB(A)	4 dB(A)

- Values determined using the procedure described in the standard **EN 13862**.
- The measurements are made with new machines. Actual values may vary with site conditions, in terms of:
 - Wear Machine
 - Lack of maintenance
 - Inappropriate tool for application
 - Tool in poor condition
 - Unskilled operator
 - Etc...
- Measured values relate to an operator in normal use, as described in the manual position.

3 ASSEMBLY AND COMMISSIONING

In order to ensure sufficient protection during dispatch and transport, the machine and its components were packed carefully. The machine should be checked for damage upon receipt. The packing of the device consists of recyclable materials. Place them into the containers provided for recycling so that they can be recycled.

The machine may not be operated in case of damage. Damaged cables and plug connectors also pose a safety risk and must not be used. In this case notify the manufacturer immediately.

If the machine is not operated immediately after unpacking, it must be protected from moisture and dirt.

3.1 *Setting the operating position*

Set the handlebars to a suitable height for the operator before beginning work.

- Release the locking screw (1) and pull out the bar.
- Slide the handlebars into the desired position and secure with the locking screw.

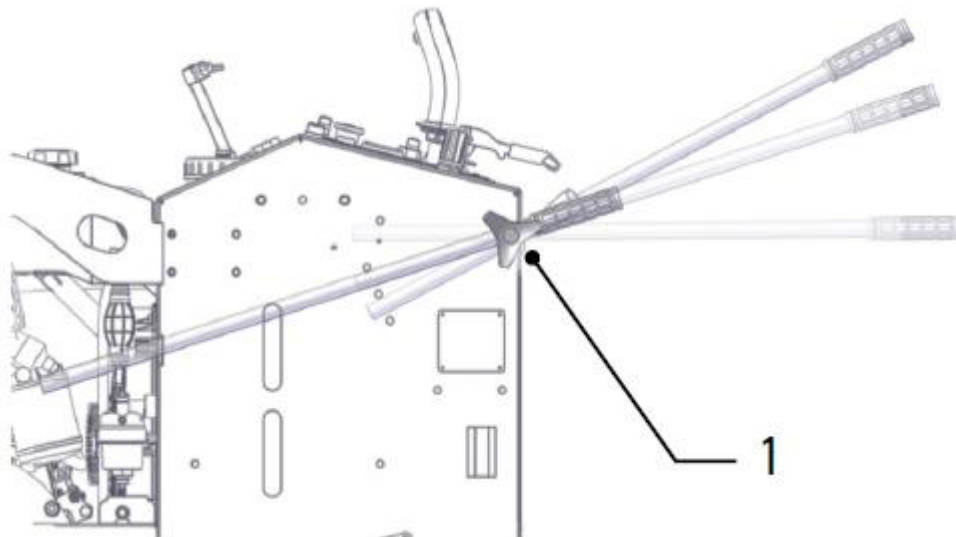

3.2 *Setting the lowering speed*

The valve should first be closed completely. Then open slowly step by step and try to find the suitable position for a suitable lowering speed.

Warning

Danger of rapid lowering of the saw blade

The saw blade can be damaged if it is lowered too fast. Segments can break out and parts can fly.

Fast lowering



Slow lowering



3.3 Refueling

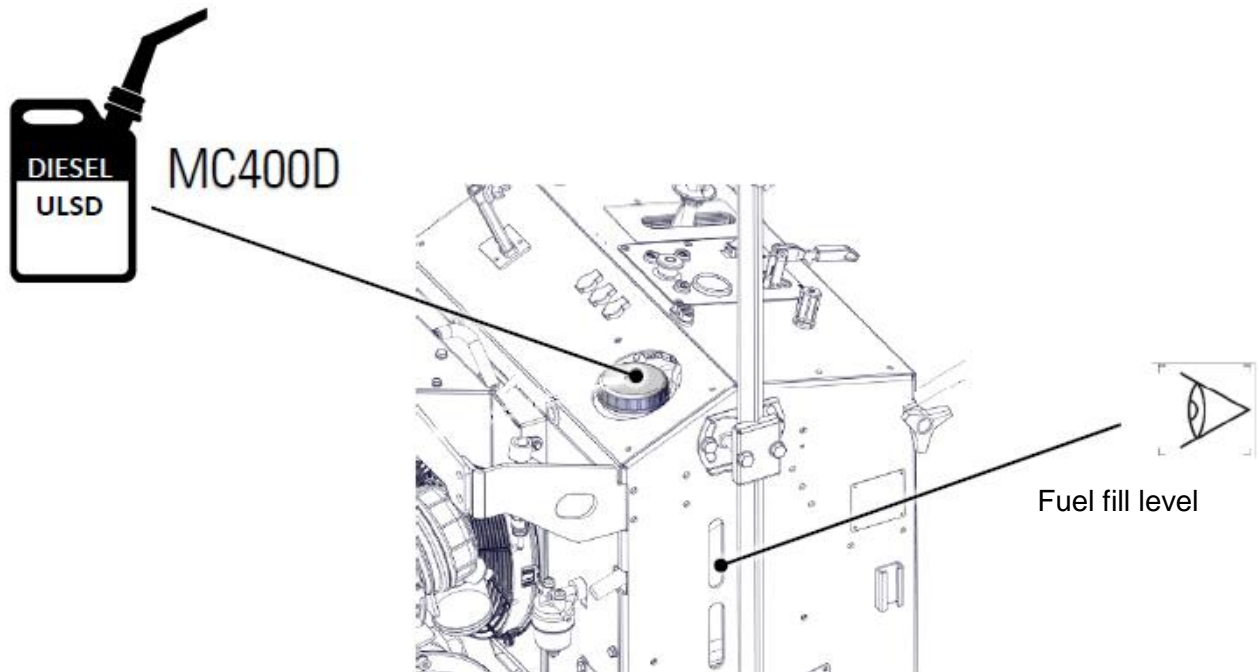

To refuel:

- Stop the engine, activate the brake and take out the ignition key.
- Clean the lid on the fuel engine, then open
- Fill with the correct fuel through a clean filling pipe or funnel.
- Do not spill any fuel. Do not overfill.
- Close the cap securely.

The fill level can be read from the oval holes on the left side of the frame.

The hand pump allows fuel to be fed from the tank to the fuel pump.
This may be necessary after long downtime.

3.4 Tool assembly

Only NORTON blades with a maximum diameter of 900 mm can be fitted on the CS 901.

Before installing the blade, make sure that it is in good condition (all the segments in place, no deformation of the blade, no visible damage to the blade, etc.).

A blade with a maximum diameter of 900 mm can be fitted. All tools used must be selected with regard to their maximum permitted cutting speed for the machine's maximum permitted rotation speed.

Before mounting a new blade, switch the machine off.

To mount a new blade, follow these steps:

- Lift the floor saw up sufficiently, activate the brake and take out the ignition key.
- Unscrew the screw (1) on the underside of the blade guard
- Remove the blade guard upwards with the handle.

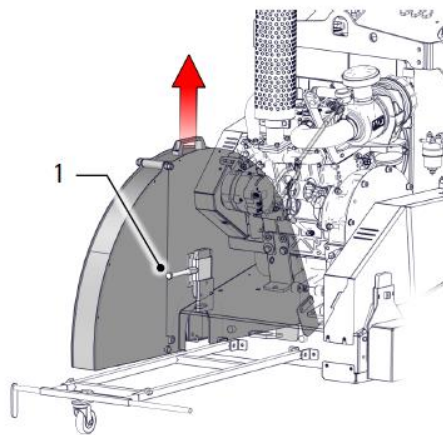

- Remove the flange screw (2) and washers (3) with the on-board tool
- Take off the mobile flange (4).
- Put the saw blade on the fixed flange (5) taking care that the direction of rotation of the disc corresponds to the arrow of the steel center
- Put the mobile flange
- Put the thrust washer on and tighten the flange screw.
- Put the blade guard on and secure with the screw (1).

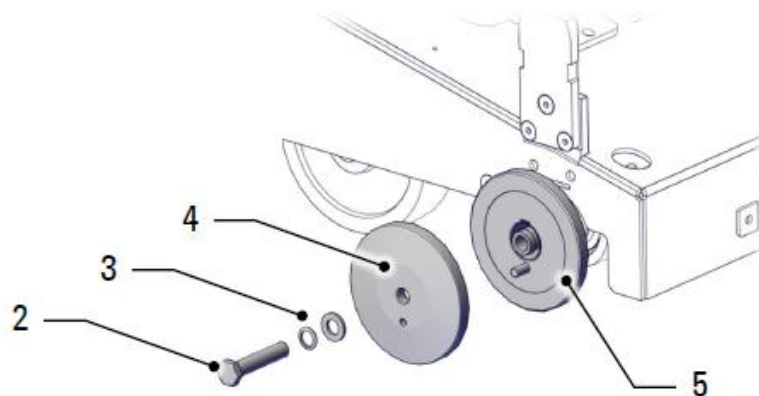

ATTENTION! The blade bore must correspond exactly to the blade shaft. Cracked or damaged bore is dangerous for the operator and for the machine.

3.5 Changing from right to left cut

The CS 901 makes it possible to make cuts on the right and cuts on the left.

CAUTION: The machine is not designed to simultaneously cut on both sides.

To change from a right cut to a left cut, please follow these instructions:

- Lift the floor saw up sufficiently, activate the brake and take out the ignition key.
- Uncouple the water hose.
- Release the locking screw (C) and take off the protection cover (B).
- Remove the blade guard (A) upwards with the handle.
- Dismount the blade.
- Mount the blade guard flange cover (B) on the other side of the blade guard.
- Release flange cover (D) and mount on the opposite side.
- Mount the saw blade and thrust washer on the other side.
- Put the blade guard in position and secure with the bolt (C).
- Turn the transverse rod of the steering rod with the pointer until it sits flush with the saw blade.

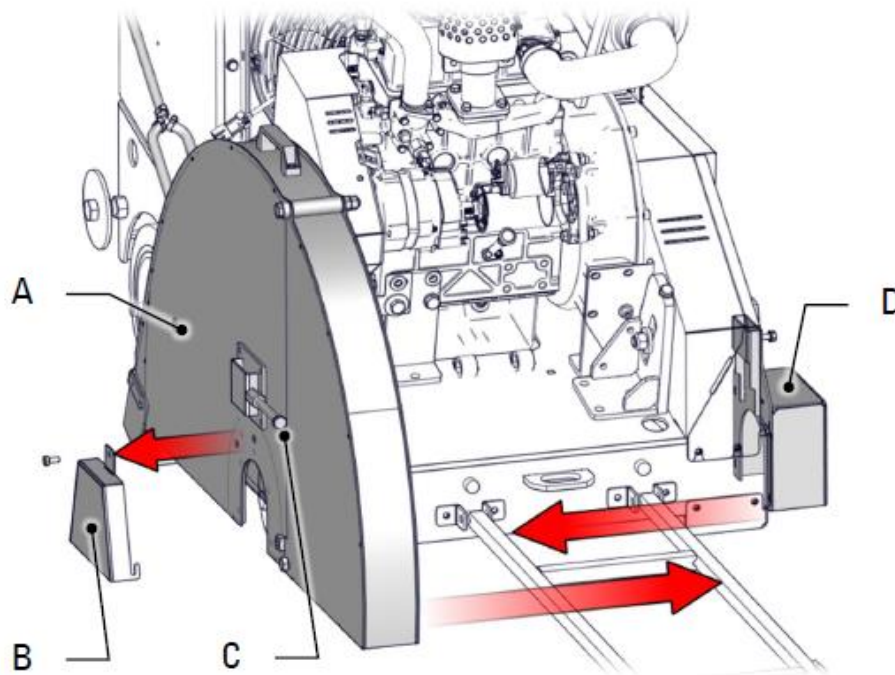

3.6 Widening the blade holder

If several or wider saw blades are to be used, the clamping zone must be widened. For that, please follow these instructions:

- Take off the blade guard
- Remove the mobile flange
- Take the pull-off screw out of its holder on the control panel.
- Screw the pull-off screw (A) into the center of the saw blade flange and remove the blade holder (B).
- Grease the new blade holder and insert up to the stop.

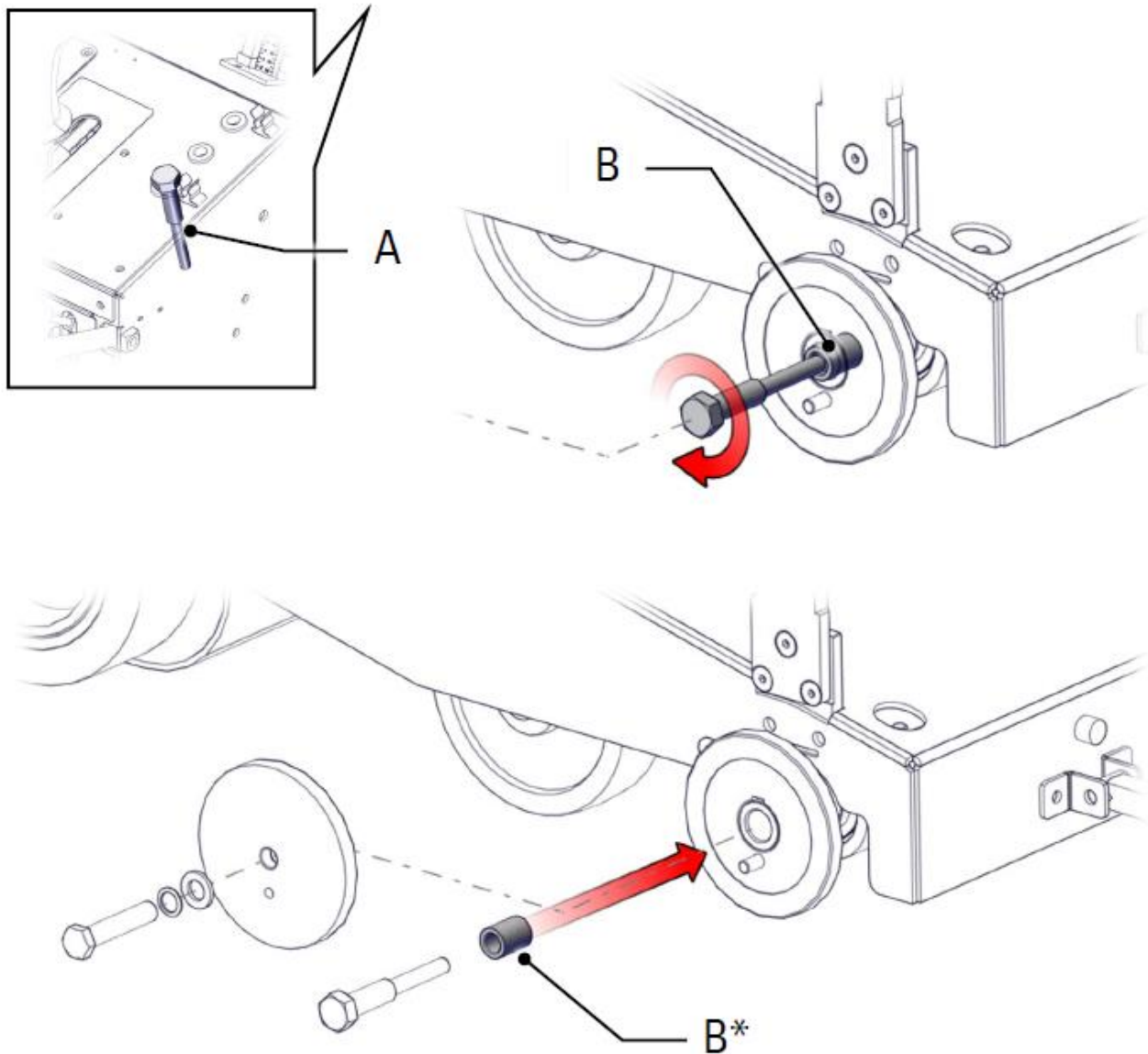

B: Blade holder with 15mm clamping zone (optional)*

If a different blade holder is used, a longer bolt to fasten the saw blade flange must be used!

3.7 Water cooling system

Connect the machine to a water supply.

Open the water-tap (note that handle on water-tap should be in line with water-flow).

Ensure that water is flowing freely in the circuit and delivered adequately to both sides of the blade, as insufficient water supply may result in premature failure of the diamond blade or excessive dust generation. If needed, adjust water flow with blade guard water tap.

In case of frost, empty the water cooling system.

3.8 Starting and switching off the machine

Make sure the blade is clear of the ground before starting the machine.

To start the motor:

- Lift the blade – No floor contact!
- Throttle to idle position
- Forward motion lever in neutral position
- Set ignition key to ignition.
- Switch on the ignition without starting the engine for 3-10 seconds depending on the outdoor temperature (maximum 60 sec).
- Start the engine. Observe the warning lights. All warning lights must turn off when the engine is running.
- Let the engine warm up for at least 3 minutes before starting the cut.

CAUTION: Do not activate the starter for longer than 30 seconds! Then wait for at least 2 minutes before attempting to start again. Otherwise, the starter coil, cable and battery may overheat.

To switch off the motor:

- Move forward motion lever to neutral position.
- Lift the saw blade out of the joint using the joystick switch.
- Engage the parking brake.
- Shut off the water supply.
- Set the engine speed setter to idle.
- Switch off the engine and remove the ignition key.

4 OPERATING THE CS 901

In order to use the floor saw safely and properly, check that the floor saw is not damaged, that the screw connections are not loose and that the auxiliary parts are in good condition.

4.1 *Site of work*

Before you start working, please check the following points:

- Remove from the site anything, which might hinder the working procedure.
- Make sure the site is sufficiently well lit.
- Place, when used, the water hose so that it can't be damaged
- Make sure you have a continual adequate view of the working area so you can intervene in the working process at any time.
- Keep other staff out of the area, so you can work securely.

4.2 *Cutting method*

In this section, you can find instructions on how to make a straight cut at the desired depth.

4.2.1 Preparing your cut

Before starting the machine,

- Draw a line on the floor over the cutting length.
- Make sur that the machine is connected to the water net.
- Make sure you have filled the engine tank with fuel. No petrol is supplied with the machine.
- The engine is shipped with oil. Check oil level before starting. Top up if required.
- Make sure you have mounted the correct blade as recommended by the manufacturer depending on the material to be worked, the working procedure (wet cut) to be carried out, and the efficiency required.
- Make sure that the flanges securely hold the diamond blade.
- Make sure that the blade is not touching the floor before starting the motor.
- Adjust the handle to a comfortable position.
- Roll the machine until the blade is over the line.
- Lower the guide-a-cut so it touches the line.
- Align front cutting guide, guide attached to blade cover and rear cutting guide with the line.

4.2.2 Cutting the floor

You can now start the engine.

When the engine is running and has warmed up, you can make your cut:

- Set the engine speed setter to maximum speed (9).
- Activate the water supply.
- Lower the saw blade using the joystick (7) until the blade scratches the surface and set the cutting depth display (6) to zero.
- Slowly lower the saw blade via the switch on the joystick (7) to the desired cutting depth. If necessary, if necessary, adjust the lowering speed with the potentiometer (15).
- Release the parking brake with the lever (13).
- Slowly initiate forward movement via the forward motion lever (7).
- Adjust the feed rate to the cutting conditions.

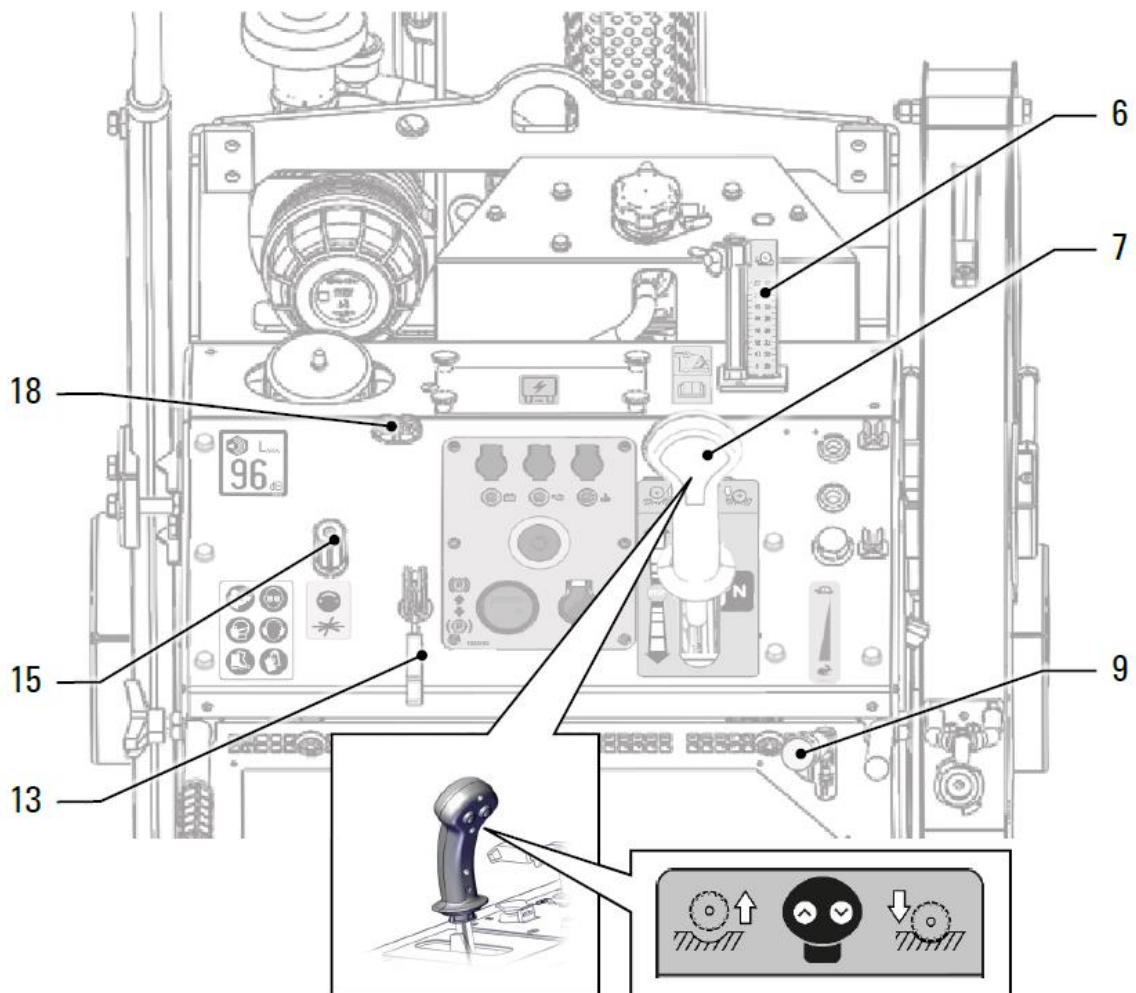

Once the cut is made:

- Move forward motion lever to neutral position.
- Lift the saw blade out of the joint using the joystick switch.
- Engage the parking brake.
- Shut off the water supply.
- Set the engine speed setter to idle.
- Switch off the engine and remove the ignition key.

4.3 Cutting with the blade guard opened

The CS 901 allows cuts flush with the wall with its blade housing which can be folded up.



To put the blade guard on this position:

- Switch off the drive engine
- Wait for all parts to come to a standstill
- Release the side bolts on the blade guard (1).
- Fold the blade guard upwards.
- Tighten the bolts (2) to secure.
- Start the drive engine and cut.

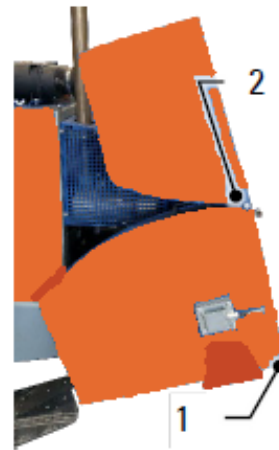

Once the cut is made:

- Switch off the drive engine
- Wait for all parts to come to a standstill
- Release the side bolts on the blade guard (2).
- Fold the blade guard down.
- Tighten the bolts (1) to secure.

4.4 Setting toe in

The saw blade for deep cuts tends to pull the machine to one side. This is completely normal and can easily be corrected via the toe-in adjustment to ensure a straight cut.

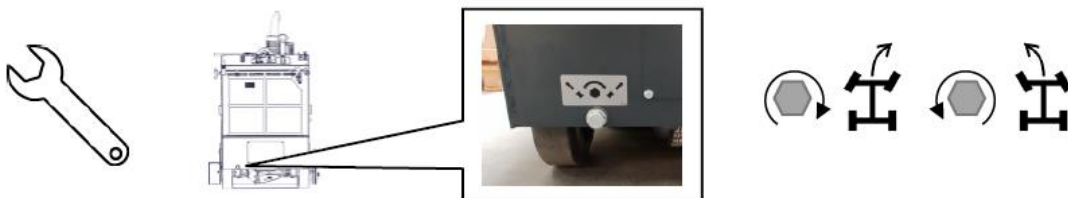

To adjust the parallelism, turn the adjustment screw

- Clockwise -> floor saw runs to the right
- Anticlockwise -> floor saw runs to the left

5 TRANSPORT AND STORING

Lifting tackle with sufficient carrying capacity must be used when moving with a crane. Examine the lifting tackle for damage before it is used.

Appoint an expert instructor for the hoisting work.

Only lift the floor saw as described in the operating manual using lifting gear.

Only use a suitable transport vehicle with an adequate load capacity.

Secure the load properly in compliance with the regulations. Use suitable attachment points.

The saw engine must also be switched off or disconnected if there is a slight change of location.

5.1 Moving the CS 901

Risk of injury due to rotating saw blade

By touching the rotating saw blade clothes can be pulled in and limbs severed.

- Any movement of the machine outside the area where cutting work is to be performed must be done when the tool is not rotating.
- During relocation, the operator must not leave the intended position behind the handlebars.

Danger in the work area

The running machine has a high potential for injury if it is not operated and used responsibly and in accordance with the specifications.

- The operator must stay behind the handlebars when cutting.
- The floor saw may only be operated by one person. Direct other persons out of the cutting area or block this area.
- The parking brake must always be activated during pauses in cutting.

The hydrostat drive can be bypassed (Bypass). You can switch between freewheel and active drive with the orange lever. The machine can be moved by hand in freewheel.

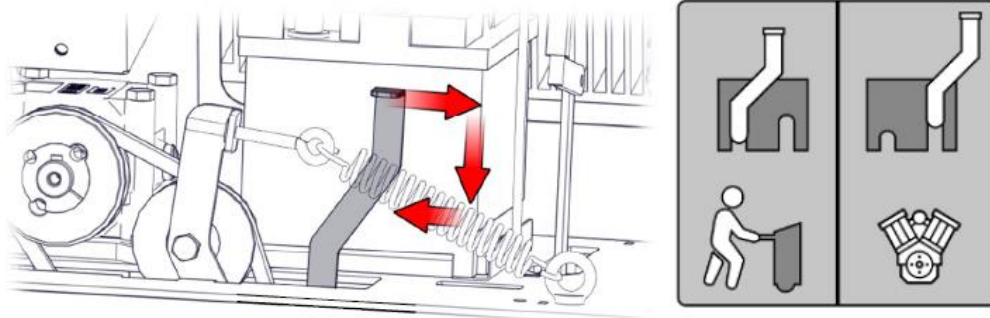

To active the freewheel mode:

- First move the lever to the right, then push it down and engage in the bottom left position.

To active the drive mode:

- Lever engaged in top right position

5.2 Transport position

Danger of crushing due to unsecured machine

Injuries due to the unintentional change of the position of the machine or the falling of parts.

- Only transport the floor saw in transport position.
- Secure the floor saw at the load-securing points.

Machine transport

Significant inclines must be avoided when transporting the floor saw. Fuel may leak out, or engine oil run into the combustion chamber of the engine and damage the engine.

All movable parts which could fall or swing during transport must be removed.

The lug at the front of the frame can be used to secure the machine when loading it by ramp using a winch.

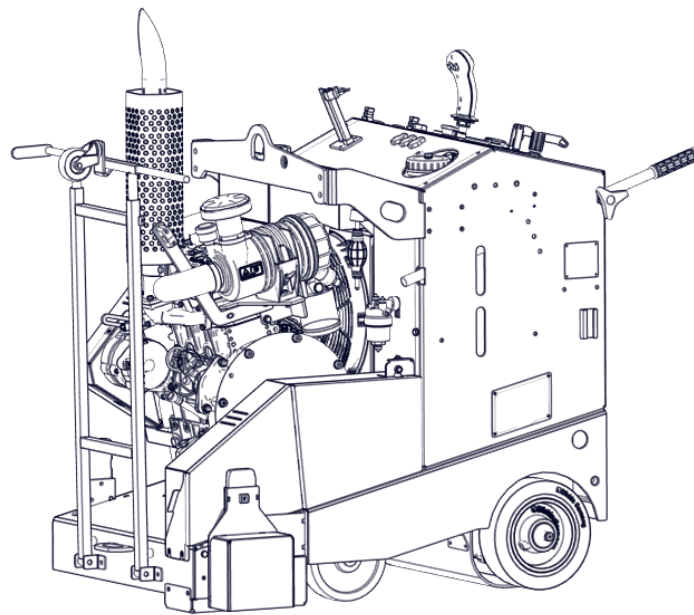

To put the machine in transport position:

- Switch off the drive engine and take out the ignition key.
- Engage the parking brake.
- Push the handlebars into the frame and secure.
- Take off the blade guard.
- Remove the saw blade.
- Fold in the steering rod in towards the machine and secure with rope.
- Secure or remove loose parts.

5.3 Relocating using a crane

Swinging loads

Danger of injury due to falling parts.

- Do not stay under hoisted machines or parts.
- Only use undamaged hoisting devices with the sufficient load bearing capacity and length.
- The machine must only be moved in the transport position.

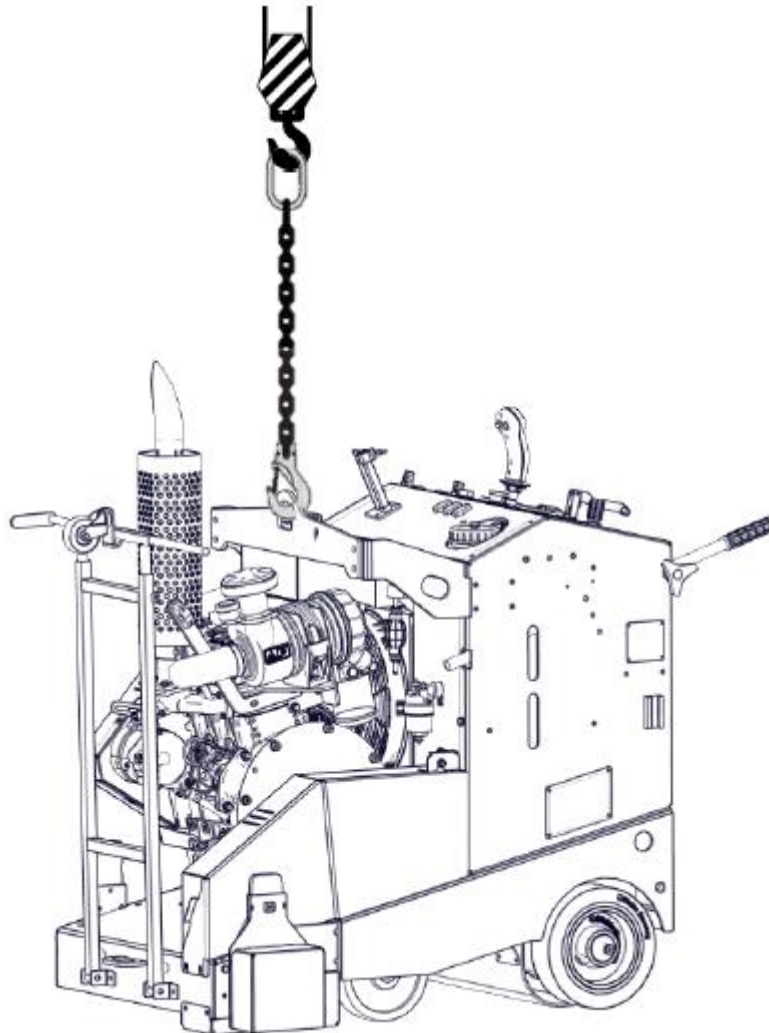

Move machine to transport position (see 5.2)

- Suspend the floor saw by the crane eyelet using a sling with sufficient load-bearing capacity.
- Determine a competent instructor before the lifting operation
- Only use a suitable transport vehicle with an adequate load-bearing capacity
- Raise carefully and observe the center of gravity
- Always keep an eye on the joint cutter
- For recommissioning, proceed according to the operating instructions

5.4 Securing the machine for transport

Injuries due to sliding or tilting of the machine

People can be crushed by accidental position changes of the machine.

- Only ever transport the machine in transport position.
- Secure the machine at the suitable attachment points.
- Use suitable lashing material.
- Observe permissible total weight of the transport vehicle.

Lashing points:

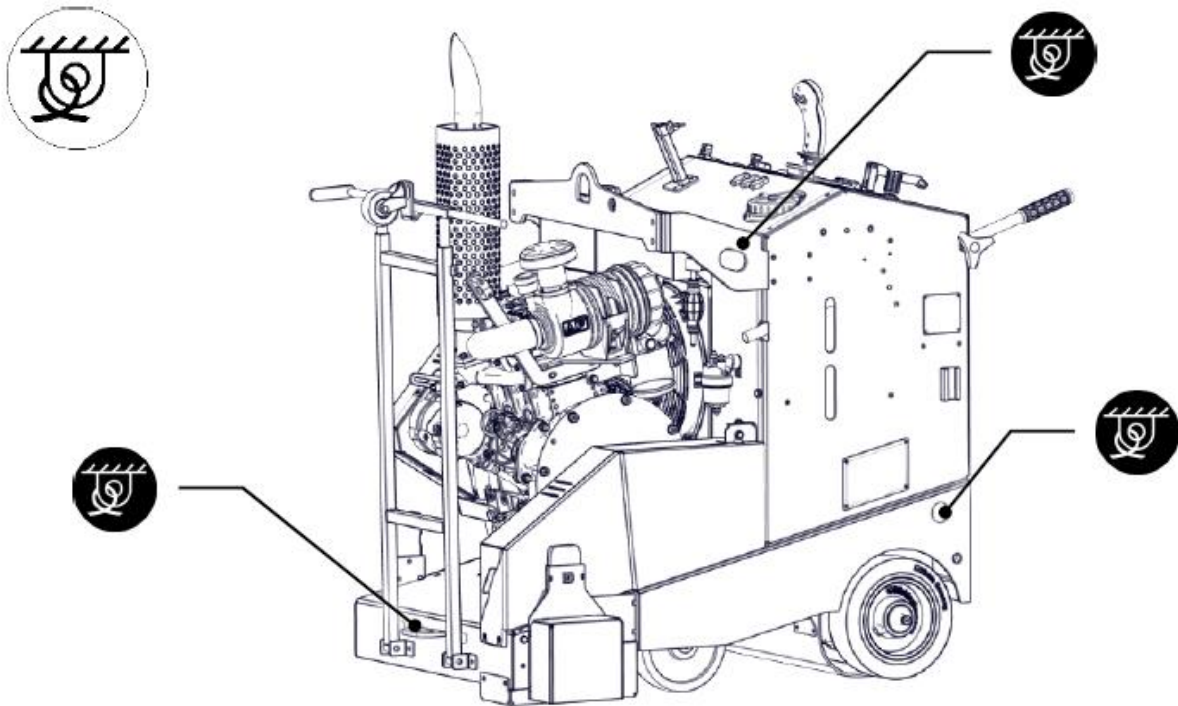

- Move machine to transport position (see 4.1)
- Secure the floor saw to the sufficient suitable lashing equipment at the marked lashing points.

5.5 Machine storage

The machine must be stored in a clean, dry, frost-free place. Disconnect the negative pole of the battery. During long downtimes, the crankshaft of the engine must be turned by at least 180° every 6 months to redistribute the valve-spring tension. The engine oil should be drained for storage of over 6 months.

5.6 Disposal

Render the worn out devices unusable once the period of use has expired, and especially when there are malfunctions.

Dispose of the machine according to the environmental regulations valid in your country. Electrical waste must not be dumped in general waste. Take the machine to a central collection point.

6 MAINTENANCE AND SERVICE

CAUTION: to perform maintenance of the machine, always switch it off. Always wear a mask and safety shoes, goggles and gloves while performing the maintenance of machine.

6.1 Maintenance of the machine

To ensure a long-term quality from the cutting with the CS 901, please follow the maintenance plan below:

Before use	Conduct a visual inspection for obvious damage and defects
	Check the protective device
	Check the engine oil level
	Check the air filter service display
	Check the cooling water level
	Check the V-belt tension
After every use	Thoroughly clean the floor saw
	Lubricate the cutting shaft bearing
Every 50h	Check/empty the water separator
	Check the fuel pre-filter
	Lubricate the lubricating points
Every 250h	Check the alternator and ventilator belts
Every 500h	Add coolant additive
	Change engine oil and filter
	Replace air filter element (sooner if necessary)
	Replace all fuel filters
	Clean radiator fins (sooner if necessary)
	Check the hydraulic piping and screw fittings
Every 1000h	Replace the alternator and ventilator belts
For all matters over 1000h	See the engine manufacturer's operating manual
The maintenance instructions refer to normal, intended use. When the machine is used under extreme weather conditions, or under continuous operation, the service intervals must be adapted accordingly.	

Machine cleaning

The life of your machine depends a lot on its maintenance. So clean it at the end of each day.

Checking and changing the belt

After one hour of work, the belt heats up and stretches. Therefore, you have to re-tighten it. Regularly check the tension of the belt, in particular at the end of each week and after a breakdown or incident.

To check the tension of the belt:

- Release the screw connection (1)
- Remove the belt housing (2), the cutting shaft covering (3) and the cover (4)

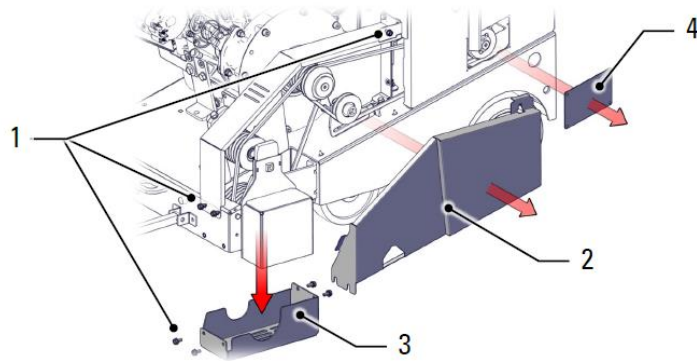

To check the tension of the belt or to change the belt:

Drive belt (1 x SPZ 1400):

- Release the locking screws (5) and use the tensioning screw (6) to slacken the belt.
- Remove the V-belt for the drive (7) if necessary.
- Turn the tensioning screw (6) clockwise.
- Screw up the bolts (5) tightly.
- Tighten lock nut.

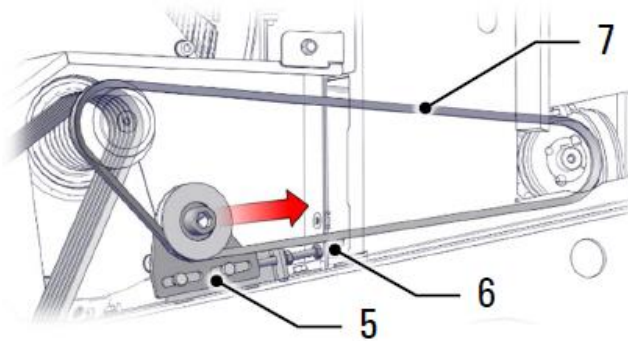

Cutting shaft belt (6 x SPZ 1202 – ISO 1318 anti-static):

- Release the locking screws (8) and turn the belt pulley downwards using the screw (9).
- The drive belts are now slackened and can be taken out.
- Lay in the new drive belts and assemble in the reverse order.

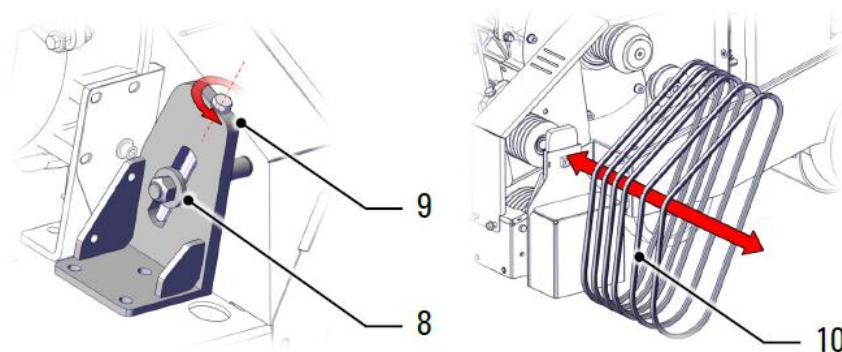

When replacing belts, always take a set of belts. Never limit yourself to replacing a single belt. After any check or change of belts, please close the cover.

Hydrostat drive belt (1 x SPA 832):

The hydrostat belt is tensioned automatically by a spring. The tension can be adjusted if necessary. To replace the hydrostat belt, also remove the lower cover (11). Loosen the back cover (10) with a square key and remove.

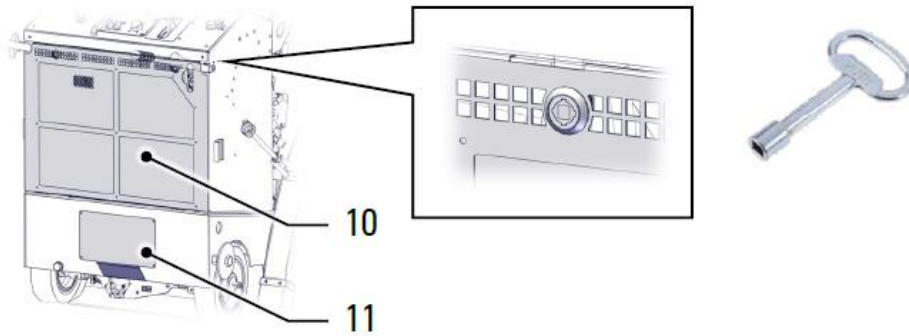

- Release lock nut.
- Turn the tensioning screw (12) clockwise.
- Tighten lock nut.

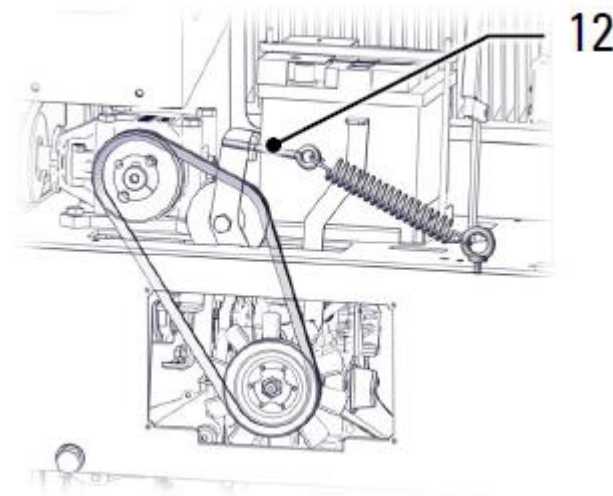

Lifting cylinder hydraulic oil

The hydraulic fluid used must be of HVLP (High Volume Low Pressure) quality (according to DIN 51524-3 / ISO 6743/4) in the ISO viscosity class 68.

Hydrostat gear oil

The gearbox is filled with SAE 20W-50 engine oil by the manufacturer. (approx. 2l) The requirements and the quality standards are included in the gearbox manufacturer's operating manual.

Water

The water pressure in the supply line must not exceed 5 bar. If necessary, use a pressure reducer.

Lubricant

Only use quality grease on the grease nipple. The grease used on the floor saw is "Energrease LS2 BP". (Lithium saponified multi-purpose grease of NLGI grade 2 according to DIN 51818/NLGI GC - LB grade 2)

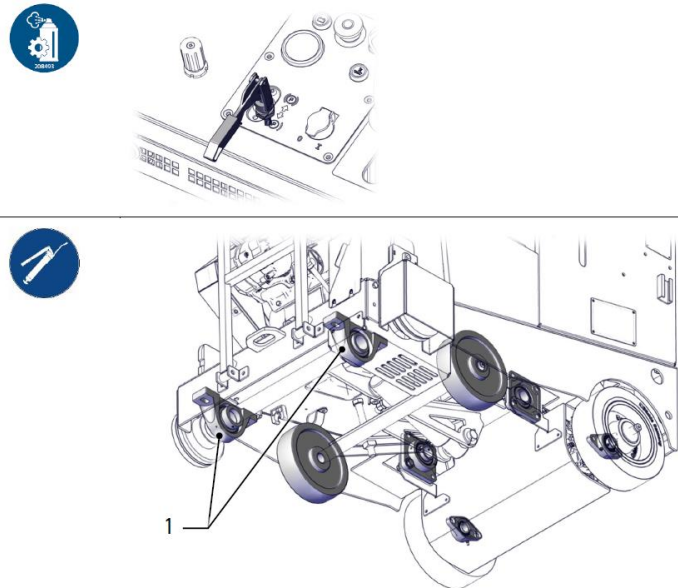

1 → After every use

Other → Every 100h

Fuses

Standard motor vehicle blade fuses are used, type C according to ISO 8820-3 (ATO, blade-type). Always replace fuses with ones of the same type only.

F1	40 A	Main fuse
F2	25 A	Engine fuse
F3	10 A	Socket
F4	10 A	Socket
F5	10 A	Socket

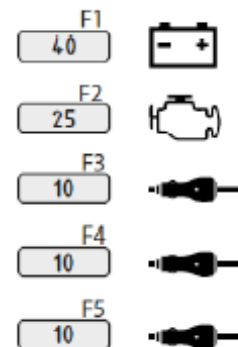

Battery

12V 45Ah - 420A starting current (replacement only by same type)

Check the battery voltage regularly and recharge or replace the battery when necessary.

WARNING

Risk of explosion and chemical burns

Explosive oxyhydrogen gas is produced when charging the battery. Battery acid is corrosive.

- Keep ignition sources away.
- Pay attention to correct polarity.
- Wear personal protective equipment.
- Before welding work on the machine, always disconnect the negative battery pole and the control electronics as far as possible.

Bleeding the hydrostatic drive

The hydrostatic drive must be bled:

- During initial commissioning at the customer's premises
- After long transport
- After longer standstill > 1 month
- In case of malfunction of the traction drive

Jack up the floor saw safely. Drive wheels must run freely:

- Push the lever down to open the bypass valve.
- Run the engine with $\frac{3}{4}$ throttle position. 3.
- Move the joystick slowly forward and backward 5 to 6 times. Lift lever to close bypass valve and repeat procedure.
- Check oil level and repeat procedure if necessary.

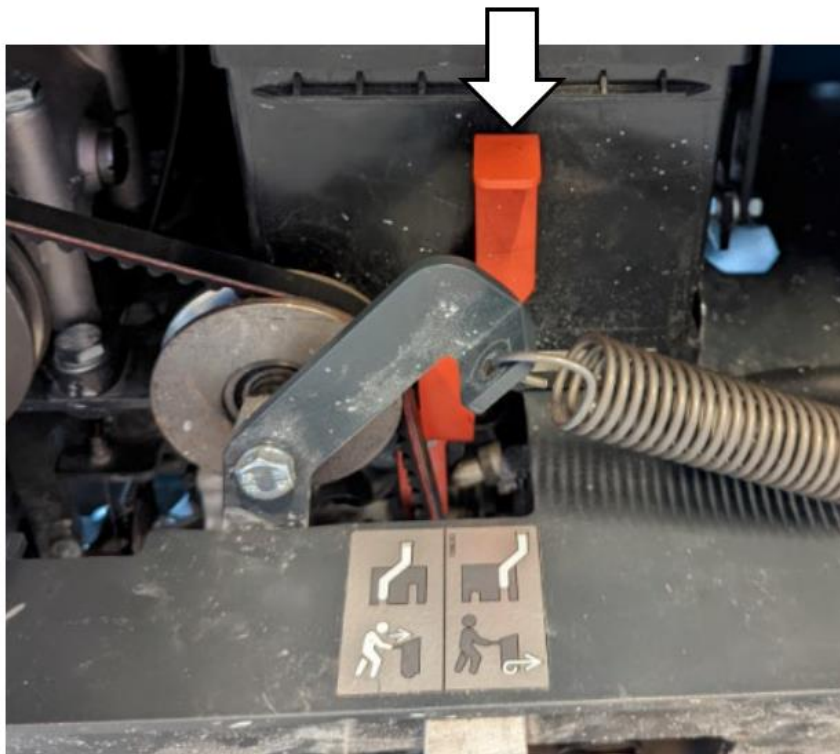

6.2 Maintenance of the engine

The floor saw must be filled with sulphur-free DIESEL (ULSD <15 PPM) in accordance with EN 590. B20 biodiesel is also permissible, but leads to greater maintenance requirements. The requirements and the quality standards are included in the operating manual of the engine.

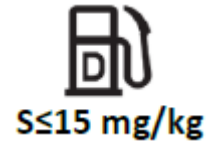

Engine oil

The engine is filled with SAE 10W-40 engine oil by the manufacturer. (3.4 min – 4.4L max) Only engine oil approved by the manufacturer API CK4, ACEA E9 or EFC-3 or better may be used. The requirements and the quality standards are included in the operating manual of the engine.

Check the oil level daily before starting work.

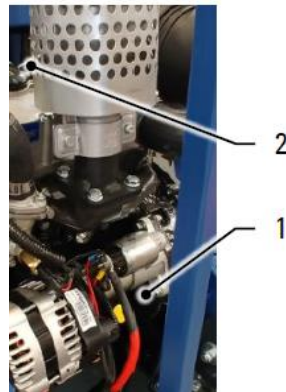

Check the oil level with the oil dipstick (1). If necessary, open the flap (2) and fill up with oil through the opening under it. Do not spill any oil. Do not overfill.

Draining the engine oil:

- Use the hydraulics to move the machine upwards until the engine is horizontal.
- Switch off the engine of the floor saw.
- Guide the drain hose out of the frame.



- Unscrew the protective cap from the oil drain hose.
- Drain the old oil into a catch pan and dispose in accordance with the regulations.
- Change the oil filter and fill with clean oil (3.4L min – 4.4L max)

Dispose of engine oil safely

Prevent environmental pollution and observe the country-specific regulations.

- A collecting vessel must be placed underneath when draining the engine oil.
- Dispose of old engine oil correctly with your disposal contractor so that it does not harm the environment.
- Observe the engine manufacturer's operating instructions, enclosed with each machine, and pay particular attention to the safety and maintenance instructions!

Hand pump and water separator

The hand pump allows fuel to be fed from the tank to the fuel pump. This may be necessary after long downtime.

The water separator should be checked regularly (every 50 operating hours).

Drain any water which may be present into a suitable container and dispose in accordance with the regulations. If necessary, vent the separator through the upper screw valves.

Engine coolant

Only use engine coolant that meets the requirements of ASTM D6210. Mix 1:1 with water. The manufacturer recommends Perkins ELC.

Perkins ELC allows 6000 operating hours (3 years).

ASTM D6210 allows 3000 operating hours (2 years).

The details are included in the operating manual of the fuel engine.

Air filter

The air filter filters the ambient air and prevents foreign matter from penetrating into the combustion chamber. Over time, dust accumulates on the air filter and reduces the through-flow of air.

This reduces its efficiency, which can lead to damage to the engine.

Therefore, we recommend that you check the air filter regularly, replacing it as necessary.

Filter condition

The air filter is equipped with a service display.

When there is a READ display in the viewing window, the air filter must be serviced immediately.

Pressing on the cap (B) resets the display.



Replacing the air filter

- Release the clamps and remove the cap 4.
- Remove the filter cartridge 3 and clean the inside of the housing.
- Insert the new filter cartridge.
- Secure the cap again with the clamps.

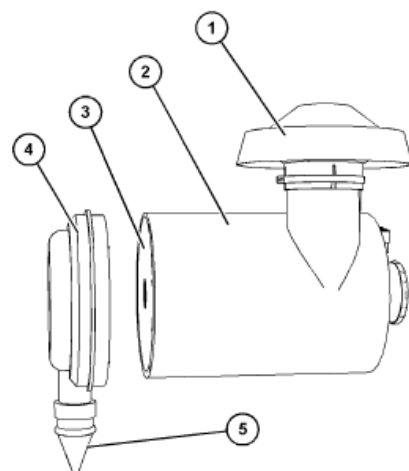

Further maintenance

For further maintenance, please contact the nearest engine maintenance center.



7 BREAKDOWNS: CAUSES AND CURES

7.1 Breakdown-finding procedures

Should any breakdown occur during the use of the machine, turn it off. Let only qualified staff make any intervention other than the ones described in the previous section.

7.2 Warning lights

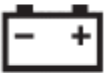
The warning lights notify you of a fault in the system. The indicated fault must be resolved immediately to prevent damage to the machine.

Warning Lights	Signification	Resolution
	<p>Battery / alternator fault Lights up upon ignition and turns off when the engine is running. Display while the engine is running = defective alternator.</p>	<p>Check alternator Caution: Starter and blade lifting failure if the battery is empty</p>
	<p>Oil level warning light Lights red when the ignition is switched on. Turns off following successful start-up. If the warning light shines red when the engine is running, the oil level is too low.</p>	<p>Stop the engine. Check the oil level and fill up if necessary. (See also the internal combustion engine operating manual.)</p>
	<p>Engine Overheat / High cooling water temperature Engine switches off automatically. Warning lamp flashes.</p>	<p>Allow the machine to cool down, check the cooling water level and top up with water if necessary. ATTENTION. Restarting the engine is only possible when the light stops flashing.</p>

7.3 *Trouble-shooting guide*

Trouble	Possible source	Resolution
Poor cutting performance	Saw blade is blunt	Replace saw blade
	Too little cooling water	Check/rinse out the water supply
	V-belts slipping	Retightening the V-belts
	Diesel engine does not have the full output	Check the air filter, check the fuel filter See operating manual of the diesel engine
Floor saw does not start	Fuel tank empty	Refill with fuel
	Fuel filter dirty	Disassemble and clean the fuel filter
	Feed lever in wrong position	Move the feed lever to centre position
	Battery empty	Charge battery, check alternator
	More serious fault	Contact nearest engine maintenance centre
Joint cutter cannot be lifted out of place	Hydraulic tank empty	Fill the hydraulic tank
	Hydraulic pump defective	Replace hydraulic pump
	Battery empty Fuse blown	Charge or replace battery Check fuse and replace if necessary

7.4 Circuit diagram

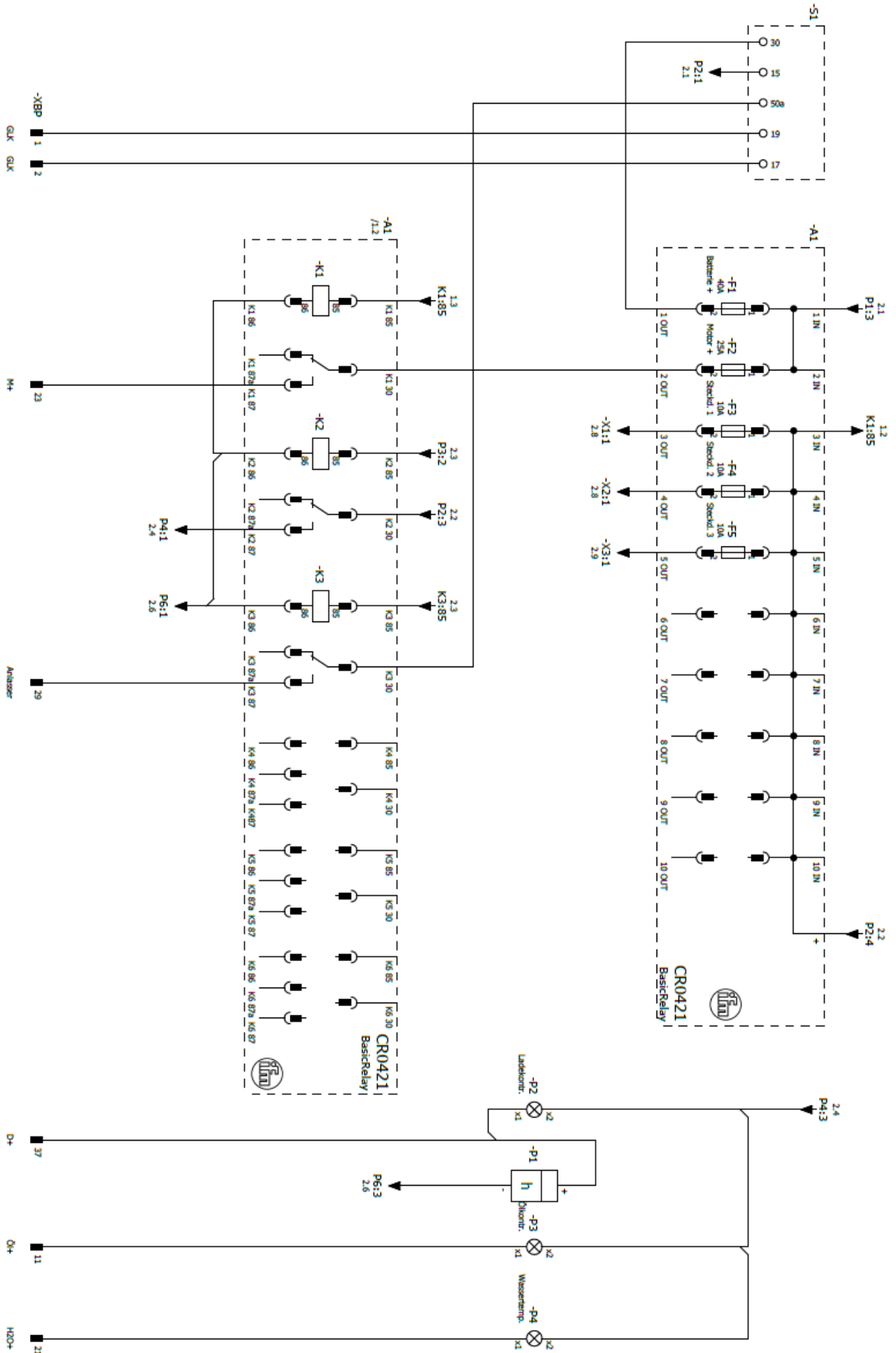

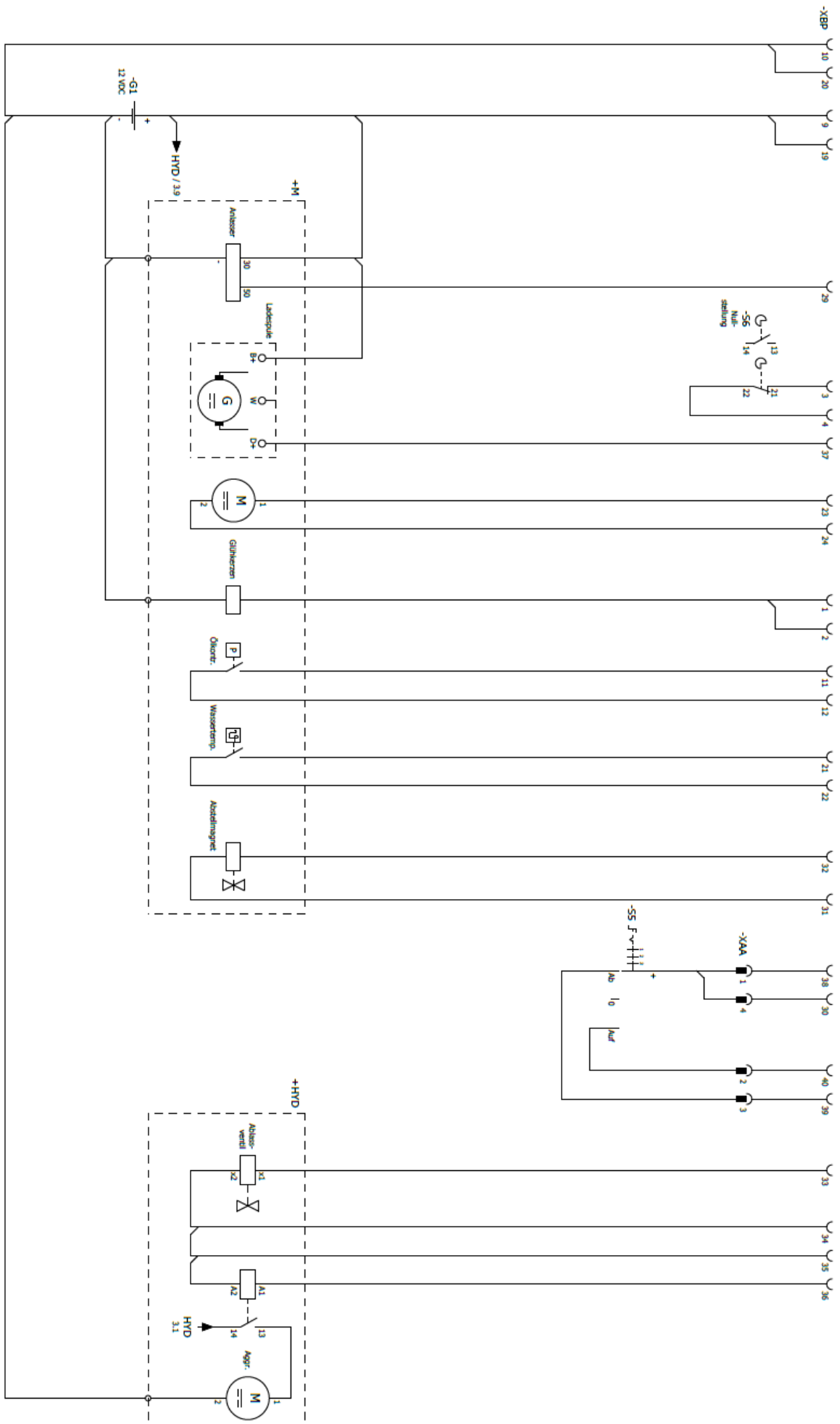

7.5 Customer service

When ordering spare parts, please mention:

- The serial number (7 digits).
- The code of the part.
- The exact denomination.
- The number of parts required.
- The delivery address.
- Please indicate clearly the means of transportation required such as "express" or "by air". Without specific instructions, we will forward the parts through the means which seem appropriate to us --- but which is not always the quickest way.

Clear instructions will avoid problems and faulty deliveries.

If not sure, please send us the defective part.

In the case of a warranty claim, the part must always be returned for evaluation.

Spare parts for the motor can be ordered with the manufacturer of the motor or with their dealer, which is often quicker and cheaper.

This machine has been manufactured by: Saint-Gobain Abrasives S.A.

190, Bd. J. F. Kennedy

L- 4930 BASCHARAGE

Grand-duché de Luxembourg.

Tel.: 00352-50 401-1

Fax: 00352- 50 16 33

<http://www.construction.norton.eu>

e-mail: sales.nlx@saint-gobain.com

7.6 Spare parts

In order to consult the spare parts lists, we invite you to visit the after-sales website of Norton Clipper by using the following address:

<https://spareparts.nortonabrasives.com>

For a quick access, you can also use the QR Code shown below using your mobile phone:



This electronic catalogue provides exploded views and spare parts lists for different machines designed by Norton Clipper so you can find references you need.

Guarantee can be claimed and technical support obtained from your local distributor where machines, spare parts and consumables can be ordered as well:

SAINT-GOBAIN ABRASIVES
INDUSTRIEWEG 21
9420 ERPE-MERE
BELGIUM
TEL: +32(0) 2 267 21 00

SAINT-GOBAIN CONSTRUCTION
PRODUCTS CZ A.S
DIVIZE ABRASIVES
SMRČKOVA 2485/4
180 00 PRAHA 8
CZECH REPUBLIC
TEL: +420 255 719 326
FAX: +420 255 719 321

SAINT-GOBAIN ABRASIVES A/S
DYBENDALSVEJENGET 2,
DK-2630 TAASTRUP
DENMARK
TEL: +45 4675 5244

PO BOX 643706
FORTUNE TOWER OFFICE 2106
JLT BLOCK C
(NEXT TO METRO STATION)
JUMEIRA LAKE TOWER, DUBAI
UNITED ARAB EMIRATES
TEL: +971 4 431 5154
FAX: +971 4 431 5434

SAINT-GOBAIN ABRASIFS
RUE DE L'AMBASSADEUR - B.P.8
78 702 CONFLANS CEDEX
FRANCE
TEL: +33 (0)1 34 90 40 00
FAX: +33 (0)1 39 19 89 56

SAINT-GOBAIN ABRASIVES GMBH
BIRKENSTRASSE 45-49
D-50389 WESSELING
GERMANY
TEL: +49 (0) 2236 703-0
FAX: +49 (0) 2236 703-730

SAINT-GOBAIN ABRASIVES KFT.
1225 BUDAPEST
BÁNYALÉG U. 60/B.
HUNGARY
TEL: +36 1 371 22 50
FAX: +36 1 371 22 55

SAINT-GOBAIN ABRASIVI S.P.A
VIA PER CESANO BOSCONI 4
I-20094 CORSICO MILANO
ITALY
TEL: +39 02 44 851
FAX: +39 02 44 78 266

SAINT-GOBAIN ABRASIVES S.A.
190 RUE J.F. KENNEDY
L-4930 BASCHARAGE
GRAND DUCHE DE LUXEMBOURG
TEL: +352 50 401 1
FAX: +331 83 717 792
NO. VERT (FRANCE): 0800 906 903

SAINT-GOBAIN ABRASIFS, S.A.
2 ALLÉE DES FIGUIERS
AIN SEBAÂ - CASABLANCA
MOROCCO
TEL: +212 5 22 66 57 31
FAX: +212 5 22 35 09 65

SAINT-GOBAIN ABRASIVES BV
GROENLOSEWEG 28
7151 HW EIBERGEN
P.O. BOX 10
7150 AA EIBERGEN
THE NETHERLANDS
TEL: +31 545 466466
FAX: +31 545 474605

SAINT-GOBAIN ABRASIVES AS
KARIHAUGVEIEN, 89
0186 OSLO
NORWAY
TEL: +47 63 87 06 00
FAX: +47 63 87 06 01

SAINT-GOBAIN HPM POLSKA SP. Z O.O.
UL. NORTON 1, 62-600 KOŁO
62-600 KOŁO
POLAND
TEL: +48 63 26 17 100
FAX: +48 63 27 20 401

SAINT-GOBAIN ABRASIVOS, L. DA
ZONA INDUSTRIAL DA MAIA
I-SECTOR VIII, NO. 122
APARTADO 6050
4476 - 908 MAIA
PORTUGAL
TEL: +351 229 437 940
FAX: +351 229 437 949

SAINT-GOBAIN GLASS
BUSINESS UNIT ABRASIVI
PUNCT DE LUCRU : LOC.VETIS, JUD.
SATU MARE 447355
STR. CAREIULUI 11
PARC INDUSTRIAL RENOVATIO
ROMANIA
TEL: +40 261 839 709
FAX: +40 261 839 710

SG HPM RUS
58, F. ENGELS STR.
STROENIE 2
105082 MOSCOW
RUSSIA
TEL: +74 955 408 355
FAX: +74 959 373 224

SAINT-GOBAIN
ABRASIVES (PTY) LTD
2 MONTEER ROAD
ISANDO 1600
P.O. BOX 67
SOUTH AFRICA
TEL: +27 11 961 2000
FAX: +27 11 961 2184/5

SAINT-GOBAIN ABRASIVOS, S.A.
CTRA. DE GUIPÚZCOA, KM. 7,5
E-31195 BERRIOPLANO (NAVARRA)
SPAIN
TEL: +34 948 306 000
FAX: +34 948 306 042

SAINT GOBAIN ABRASIVES AB
GÅRDSFOGDEVÄGEN 18A
168 66 BROMMA • SVERIGE
SWEDEN
TEL: +46 8 580 881 00
FAX: +46 8 580 881 30

SAINT-GOBAIN INOVATIF MALZEMELER
VE ASINDIRICI SAN. TIC. AS.
ALTAYÇEŞME MAH. ÇAMLI SOK. NO:21
ESAS OFIS PARK KAT:9 34843
MALTEPE, İSTANBUL • TURKEY
TEL: 0090-216-217 12 50
FAX: 0090-216-442 40 74

SAINT-GOBAIN ABRASIVES LTD.
UNICORN HOUSE UNIT 1, AMISON CLOSE
REDHILL BUSINESS PARK
STAFFORD ST161WB
UNITED KINGDOM
TEL: +44 1785 279 553
FAX: +44 1785 213 487



Saint-Gobain Abrasifs
190 Rue J.F. Kennedy
L-4930 Bascharage
Grand Duche de Luxembourg
Tel: +352 50 4011
Fax: +331 83 717 792
no. vert (France) 0800 906 903

www.nortonabrasives.com/fr-fr