

CDM 353

SPARE PART LIST
LISTE DE PIECES DE RECHANGE
ERSATZTEILLISTE



ENGLISH

TYPE:

S = Spare part

W = Wear part

NA = Not Available

The kits of spare parts contain all screws and bolts and the components referring itself to it.

Screws and bolts is component of standard assembly, which you can easily find at all the retailers of standard components of assembly.

All the components of standard assembly are of a quality grade 8.8.

We recommend not to use a quality grade lower than 8.8 for all the standard components of assembly.

The parts of replacements Norton CLIPPER must always be used.

Wear parts life will vary based on usage and maintenance of the machine or part. Wear parts will need to be maintained and replaced as needed. No warranty is applied to wear parts.

The components NA (Not Available) are not available in spare part.

FRANCAIS

TYPE :

S = Pièce de rechange

W = Pièce d'usure

NA = Non disponible

Les kits de pièces détachées contiennent toute la visserie et les composants s'y rapportant.

La visserie est un composant d'assemblage standard, que vous pouvez facilement trouver chez tous les détaillants de composants d'assemblage standards.

Tous les composants d'assemblage standard sont d'une classe de qualité 8.8.

Nous recommandons de ne pas utiliser une classe de qualité inférieure à 8.8 pour tous les composants d'assemblage standards.

Pour les pièces non standard, les pièces de remplacement doivent impérativement provenir de Norton CLIPPER.

La durée de vie des pièces d'usure varie en fonction de l'utilisation et de la maintenance de la machine ou de la pièce. Les pièces d'usure devront être entretenues et remplacées au besoin. Aucune garantie n'est appliquée aux pièces d'usure.

Les composants NA (Not Available) ne sont pas disponibles en pièce de rechange.

DEUTSCH

TYP :

S = Ersatzteile

W = Verschleißteile

NA = nicht verfügbare

Die definierten Ersatzteil-Set's beinhalten alle Ersatzteile wie Komponenten, Schrauben, Muttern etc.

Norm- bzw. Standardteile wie Schrauben, Muttern etc. können bei offiziellen Schrauben- sowie Komponentenhandler bezogen werden.

Alle Norm- bzw. Standardteile wie Schrauben, Muttern etc. entsprechen der Qualitäts- bzw. Festigungsklasse 8.8.

Wir empfehlen, keine Norm- bzw. Standardteile wie Schrauben, Muttern etc. unter der Qualitäts- bzw.

Festigungsklasse 8.8 einzusetzen.

Es dürfen nur geprüfte Norton CLIPPER-Ersatzteile eingesetzt werden.

Die Lebensdauer der Verschleißteile hängt von der Verwendung und Wartung der Maschine oder des Teils ab. Verschleißteile müssen gewartet und bei Bedarf ersetzt werden. Für Verschleißteile wird keine Garantie übernommen.

Ersatzteile sowie Komponenten mit dem Vermerk NA (NA=nicht verfügbar) sind nicht verfügbar.

Transmission / Transmission / Getriebe

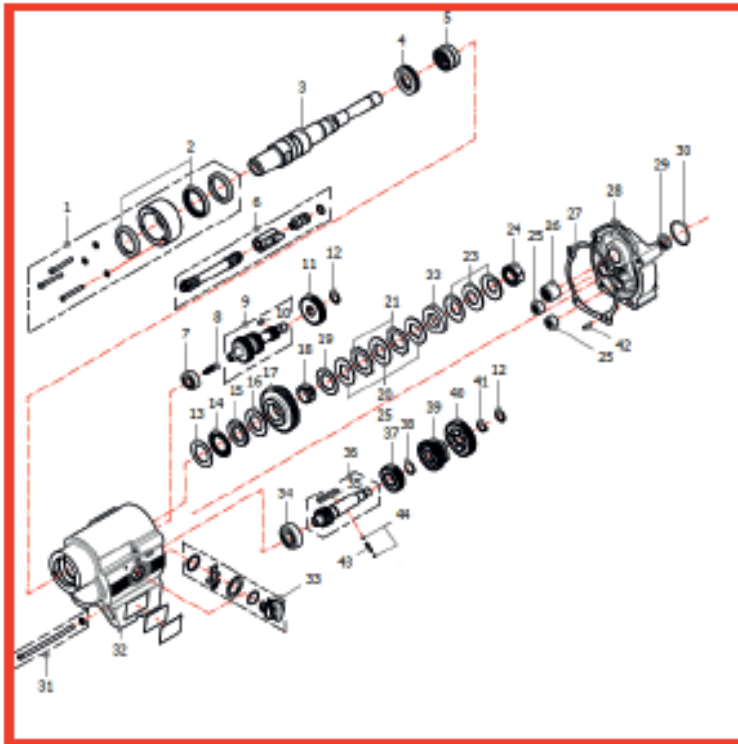

Page 4-7

Motor / Moteur / Motor

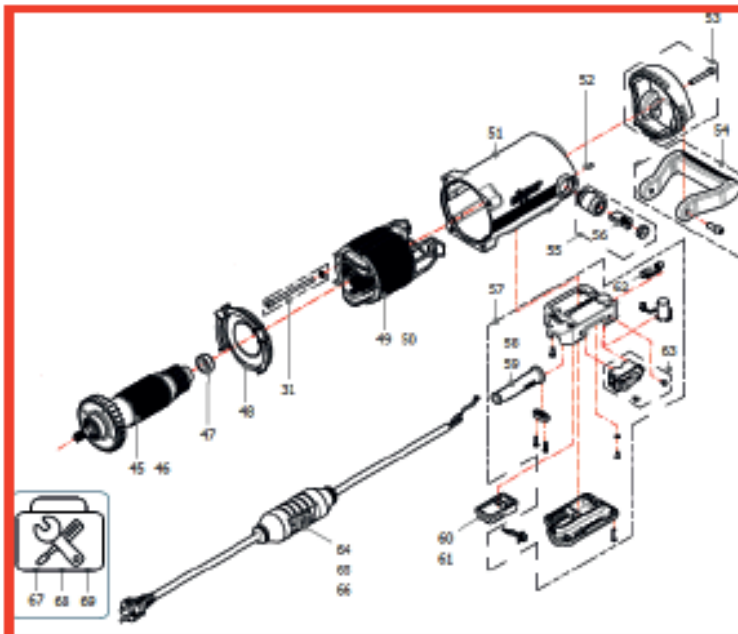

Page 8-9

Transmission / Transmission / Getriebe

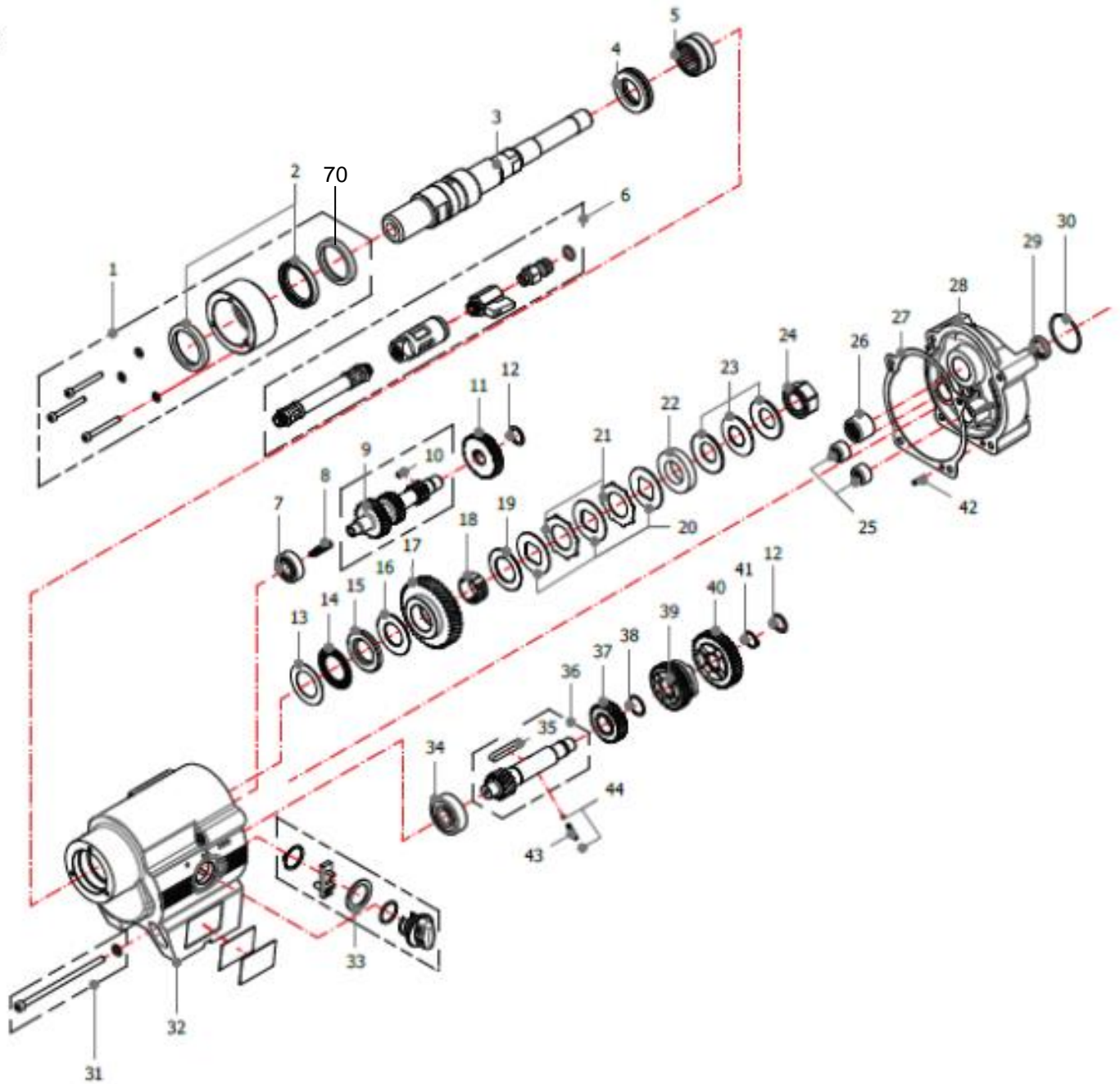

POS.	DESCRIPTION	DESCRIPTION	BESCHREIBUNG	QTY	REF	TYPE
1	Shaft seals kit	Kit joint d'arbre	Wellendichtungen kit	1	510113743	S
2	Shaft seal ring kit	Kit joint d'arbre	Wellendichtring kit	1	510113754	S
3	Main shaft	Arbre principal	Hauptachse	1	510113755	S
4	Thrust ball bearings	Butée à bille	Axial lager	1	310406742	S
5	Needle bearing	Roulement à aiguille	Nadellager	1	310406717	S
6	Waterhose	Tuyau d'arrosage	Wasserschlauch	1	310406740	S
7	Bearing	Roulement	Lager	1	310406702	S
8	Oil Shaft	Arbre d'Huile	Oil welle	1	510113670	S
9	Gearshaft kit	Kit arbre de transmission	Getriebewelle Kit	1	510113756	S
10	Key	Clavette	Paßfeder	1	310406705	S
11	Gear	Pignon	Zahnrad	1	310406791	S
12	Shim-ring	Rondelle de calage	Scheibe	1	510113758	S
13	Ring	Bague	Buchse	1	310406708	S
14	Needle bearing	Roulement à aiguille	Nadellager	1	310406719	S
15	Pressure disk	Rondelle de pression	Druckscheibe	1	310406809	S
16	Clutch disc	Rondelle friction	Rutschscheibe	1	510115913	S
17	Clutch gear	ROUE D'ENGRENAGE	ZAHNRAD	1	310406803	S
18	Needle bearing	Roulement à aiguille	Nadellager	1	310406718	S
19	Clutch disc	Rondelle friction	Rutschscheibe	1	310406805	S
20	Pressure ring	Rondelle de pression	Druckring	1	510115987	S
21	Clutch disc kit	Kit Rondelle friction	Rutschscheibe kit	1	310458384	S
22	Distance ring	Entretoise	Distance Ring	1	310406811	S

Transmission / Transmission / Getriebe

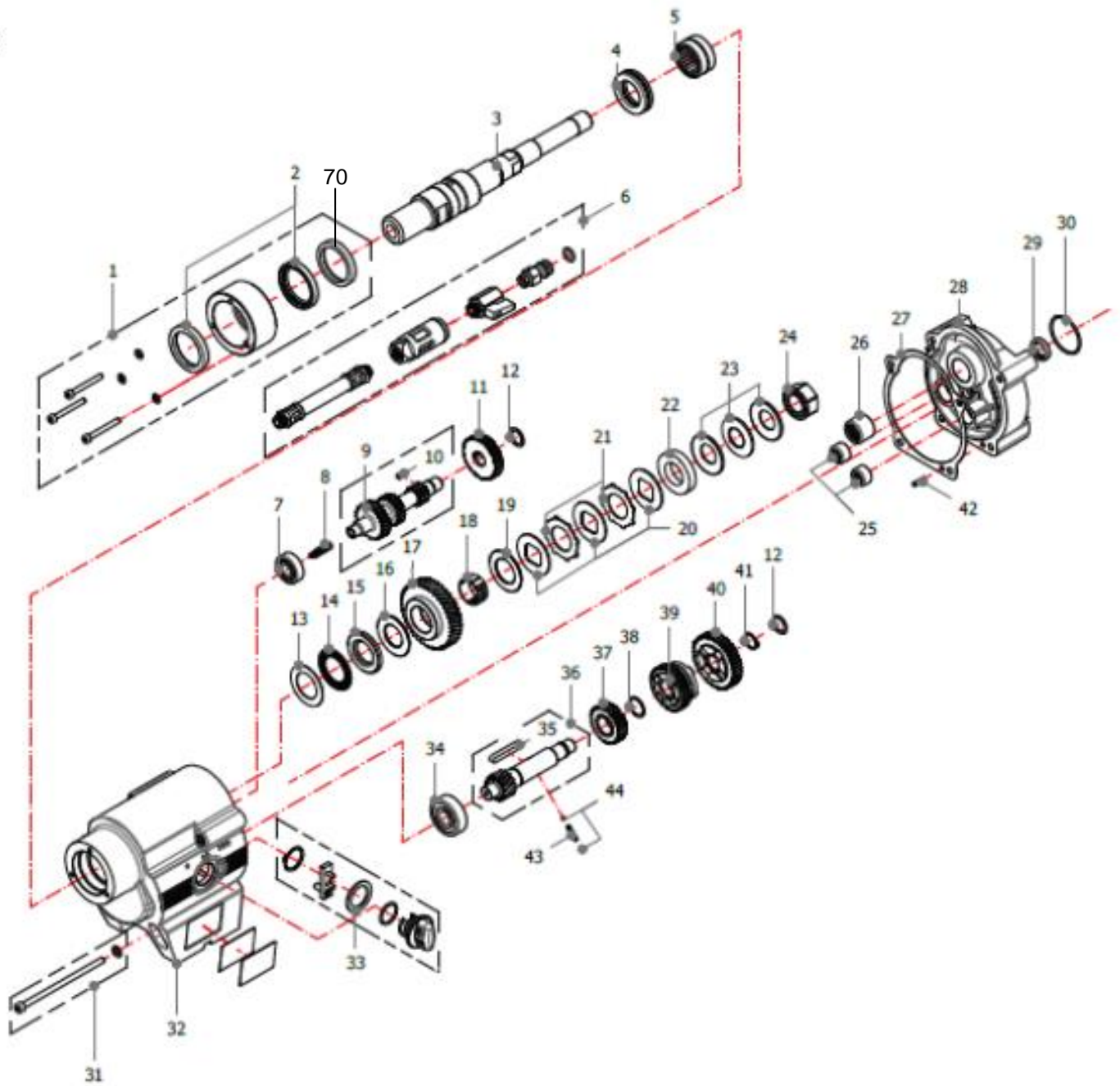

POS.	DESCRIPTION	DESCRIPTION	BESCHREIBUNG	QTY	REF	TYPE
23	Spring kit	Kit Ressort	Druckfeder kit	1	510115986	S
24	Locking nut	Ecrou	Sechskantmutter	1	310406746	S
25	Needle roller rearing kit	Kit roulement à aiguille	Nadellager kit	1	510115985	S
26	Needle roller rearing	Roulement à aiguille	Nadellager	1	310406720	S
27	Seal	Joint à lèvres	Wellendichtring	1	510113759	S
28	Gear housing	Boitier réducteur	Getriebegehäuse	1	510113760	S
29	Shaft Seal Ring	Joint d'arbre	Wellendichtring	1	310406723	S
30	O ring	Anneau	O ring	1	310406700	S
31	Screw kit	Kit de vis	Zylinderschraube kit	1	510113802	S
32	Gearbox	Reducteur	Getriebe	1	510113762	S
33	Gear shift kit	Kit selecteur	Kit schalter	1	510113745	S
34	Bearing	Roulement	Rillenkugellager	1	310406704	S
35	Key	Clavette	Paßfeder	1	510113746	S
36	Clutch shaft	Arbre sélecteur	Schaltachse	1	510114111	S
37	Gear	Pignon	Zahnrad	1	310406802	S
38	Circlip	Circlip	Sicherungsring	1	310406737	S
39	Clutch gear	Roue d'engrenage	Zahnrad	1	310406801	S
40	Gear	Pignon	Zahnrad	1	310406800	S
41	Retaining ring	Anneau de retenue	Haltering	1	510110872	S
42	Parallel Pin - Set	Goupille	Zylinderstift	1	510113748	S
43	Spring	Ressort	Druckfeder	1	-	S
44	Ball kit	Kit bille	Kugel kit	1	510113750	S
70	Shaft seal ring	Joint d'arbre	Wellendichtring	1	310406722	S

Motor / Moteur / Motor

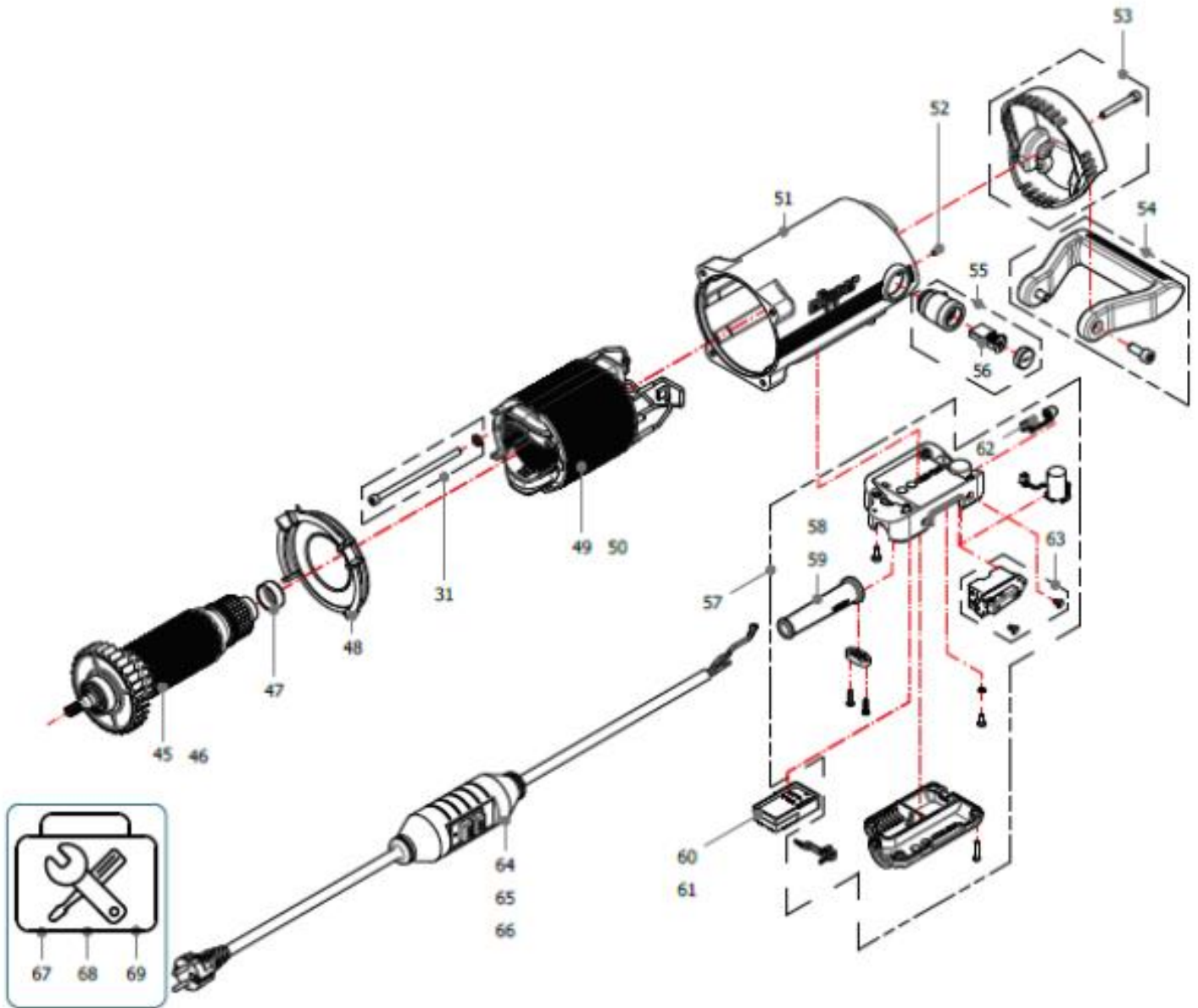

POS.	DESCRIPTION	DESCRIPTION	BESCHREIBUNG	QTY	REF	TYPE
46	Armature 3300W 115V (Assembly)	Rotor 3300W 115V (Assembly)	Anker 3300W 115V (Assembly)	1	510113804	S
45	Armature 3300W 230V (Assembly)	Rotor 3300W 230V (Assembly)	Anker 3300W 230V (Assembly)	1	510113803	S
47	Bearing Cup	Insert caoutchouc	Rubber insert	1	310406747	S
48	Air cover	Couvercle filtre à air	Luftfilterdeckel	1	510113753	S
50	Stator 3300W - 115V	Stator 3300W - 115V	Feld 3300W - 115V	1	510113806	S
49	Stator 3300W - 230V	Stator 3300W - 230V	Feld 3300W - 230V	1	510113805	S
51	Motorhousing	Boitier moteur	Motorgehäuse	1	510113785	S
52	Screw kit	Kit de vis	Zylinderschraube kit	1	510113586	S
53	End cover kit	Kit couvercle moteur	Kit motor deckel	1	510113786	S
54	Handle kit	Kit poignée	Kit handgriff	1	510113787	S
55	Brush Holder kit	Kit porte-charbon	Kohlenbürstenhal	1	510113788	S
56	Brush	Charbon	Kohlen	1	510113789	S
57	Control casing kit	Kit boitier électrique	Kit elektrische kaste	1	510113669	S
58	Control casing kit	Kit boitier électrique	Kit elektrische kaste	1	510113790	S
59	Cablehose (230V)	Passe câble (230V)	Kabeltülle (230V)	1	510113791	S
61	Motorcontrol 3300 Watt 220-240V	Module electronique 3300W 220/240V	Elektronik 3300W 220/240V	1	510113808	S
60	Motorcontrol 3300 Watt 110-130V	Module electronique 3300W 110-130V	Elektronik 3300W 110-130V	1	510113807	S
62	LED Indicator	LED	Leuchtdiode	1	510113794	S
63	Switch	Interrupteur	Schalter	1	510113795	S
64	Cable 230V/EU/PRCD	Cable 230V/EU/PRCD	Kable 230V/EU/PRCD	1	510113796	S
65	Cable 115V/UK/PRCD	Cable 115V/UK/PRCD	Kable 115V/UK/PRCD	1	510113797	S
66	Cable 230V/AUS/PRCD	Cable 230V/AUS/PRCD	Kable 230V/AUS/PRCD	1	510113798	S
67	Tools - Set	Kit outils	Kit werkzeug	1	510113799	S
68	Suitcase	Valise	Koffer	1	510113800	S
69	Manual	Manuel	Manual	1	510113801	S

SAINT-GOBAIN ABRASIVES
INDUSTRIEWEG 21
9420 ERPE-MERE
BELGIUM
TEL: +32(0) 2 267 21 00

SAINT-GOBAIN ABRASIVES, S.R.O.
POČERNICKÁ 272/96, MALEŠICE
108 00 PRAHA 10
CZECH REPUBLIC
TEL: +420 255 719 326
FAX: +420 255 719 321

SAINT-GOBAIN ABRASIVES A/S
DYBENDALSVEJENGET 2,
DK-2630 TAASTRUP
DENMARK
TEL: +45 4675 5244

SAINT-GOBAIN ABRASIVES MIDDLE
EAST
JEBEL ALI FREE ZONE,
PLOT NO. S10817
PO BOX 261484, DUBAI •
UNITED ARAB EMIRATES
TEL: + 971 (4) 8011 800
FAX: +971 (4) 8011 801

SAINT-GOBAIN ABRASIFS
RUE DE L'AMBASSADEUR - B.P.8
78 702 CONFLANS CEDEX
FRANCE
TEL: +33 (0)1 34 90 40 00
FAX: +33 (0)1 39 19 89 56

SAINT-GOBAIN ABRASIVES GMBH
BIRKENSTRASSE 45-49
D-50389 WESSELING
GERMANY
TEL: +49 (0) 2236 703-1
+49 (0) 2236 8996-0
+49 (0) 2236 8911-0
FAX: +49 (0) 2236 703-367
+49 (0) 2236 8996-10
+49 (0) 2236 8911-30

FÜR DEN FACHHANDEL
ÖSTERREICH
TEL: +43 (00) 662 430 076

SAINT-GOBAIN ABRASIVES KFT.
1225 BUDAPEST
BÁNYALÉG U. 60/B.
HUNGARY
TEL: +36 1 371 22 50
FAX: +36 1 371 22 55

SAINT-GOBAIN ABRASIVI S.P.A
VIA PER CESANO BOSCONI 4
I-20094 CORSICO MILANO
ITALY
TEL: +39 02 44 851
FAX: +39 02 44 78 266

SAINT-GOBAIN ABRASIVES S.A.
190 RUE J.F. KENNEDY
L-4930 BASCHARAGE
GRAND DUCHE DE LUXEMBOURG
TEL: +352 50 401 1
FAX: +331 83 717 792
NO. VERT (FRANCE): 0800 906 903

SAINT-GOBAIN ABRASIFS, S.A.
2 ALLÉE DES FIGUIERS
AIN SEBAË - CASABLANCA
MOROCCO
TEL: +212 5 22 66 57 31
FAX: +212 5 22 35 09 65

SAINT-GOBAIN ABRASIVES BV
GROENLOSEWEG 28
7151 HW EIBERGEN
P.O. BOX 10
7150 AA EIBERGEN
THE NETHERLANDS
TEL: +31 545 466466
FAX: +31 545 474605

SAINT-GOBAIN ABRASIVES AS
POSTBOKS 11, ALNABRU, 0614 OSLO
BROBEKKVEIEN 84,
0582 OSLO • NORWAY
TEL: +47 63 87 06 00
FAX: +47 63 87 06 01

SAINT-GOBAIN HPM POLSKA SP. Z O.O.
UL. NORTON 1,
62-600 KOŁO • POLAND
TEL: +48 63 26 17 100
FAX: +48 63 27 20 401

SAINT-GOBAIN ABRASIVOS, L. DA
ZONA INDUSTRIAL DA MAIA
I-SECTOR VIII, NO. 122
APARTADO 6050
4476 - 908 MAIA
PORTUGAL
TEL: +351 229 437 940
FAX: +351 229 437 949

SAINT-GOBAIN GLASS
BUSINESS UNIT ABRASIVI
PUNCT DE LUCRU : LOC.VETIS, JUD.
SATU MARE 447355
STR. CAREIULUI 11
PARC INDUSTRIAL RENOVATIO
ROMANIA
TEL: +40 261 839 709
FAX: +40 261 839 710

SG HPM RUS
58, F. ENGELS STR.
STROENIE 2
105082 MOSCOW
RUSSIA
TEL: +74 955 408 355
FAX: +74 959 373 224

SAINT-GOBAIN
ABRASIVES (PTY) LTD
2 MONTEER ROAD
ISANDO 1600
P.O. BOX 67
SOUTH AFRICA
TEL: +27 11 961 2000
FAX: +27 11 961 2184/5

SAINT-GOBAIN ABRASIVOS, S.A.
CTRA. DE GUIPÚZCOA, KM. 7,5
E-31195 BERRIOPLANO (NAVARRA)
SPAIN
TEL: +34 948 306 000
FAX: +34 948 306 042

SAINT GOBAIN ABRASIVES AB
GÅRDSFOGDEVÄGEN 18A
168 66 BROMMA • SVERIGE
SWEDEN
TEL: +46 8 580 881 00
FAX: +46 8 580 881 30

SAINT-GOBAIN INOVATIF MALZEMELER
VE ASINDIRICI SAN. TIC. AS.
ALTAYÇEŞME MAH. ÇAMLI SOK. NO:21
ESAS OFİSPARK KAT:9 34843
MALTEPE, İSTANBUL • TURKEY
TEL: 0090-216-217 12 50
FAX: 0090-216-442 40 74

SAINT-GOBAIN ABRASIVES LTD.
DOXEY RD
STAFFORD
ST16 1EA
UNITED KINGDOM
TEL: +44 1785 222 000
FAX: +44 1785 213 487



Saint-Gobain Abrasifs
190 Rue J.F. Kennedy
L-4930 Bascharage
Grand Duché de Luxembourg
Tel: +331 83 717 792
Fax: +352 50 16 33
no. vert (France) 0800 906 903

www.nortonabrasives.com/fr-fr