

CM 400 Junior

SPARE PART LIST
LISTE DE PIÈCES DE RECHANGE
ERSATZTEILLISTE



NORTON[®]

SAINT-GOBAIN

clipper[®]

ENGLISH

TYPE:

S = Spare part

W = Wear part

NA = Not Available

The kits of spare parts contain all screws and bolts and the components referring itself to it.

Screws and bolts is component of standard assembly, which you can easily find at all the retailers of standard components of assembly.

All the components of standard assembly are of a quality grade 8.8.

We recommend not to use a quality grade lower than 8.8 for all the standard components of assembly.

The parts of replacements Norton CLIPPER must always be used.

Wear parts life will vary based on usage and maintenance of the machine or part. Wear parts will need to be maintained and replaced as needed. No warranty is applied to wear parts.

The components NA (Not Available) are not available in spare part.

FRANCAIS

TYPE :

S = Pièce de rechange

W = Pièce d'usure

NA = Non disponible

Les kits de pièces détachées contiennent toute la visserie et les composants s'y rapportant.

La visserie est un composant d'assemblage standard, que vous pouvez facilement trouver chez tous les détaillants de composants d'assemblage standards.

Tous les composants d'assemblage standard sont d'une classe de qualité 8.8.

Nous recommandons de ne pas utiliser une classe de qualité inférieure à 8.8 pour tous les composants d'assemblage standards.

Pour les pièces non standard, les pièces de remplacement doivent impérativement provenir de Norton CLIPPER.

La durée de vie des pièces d'usure varie en fonction de l'utilisation et de la maintenance de la machine ou de la pièce. Les pièces d'usure devront être entretenues et remplacées au besoin. Aucune garantie n'est appliquée aux pièces d'usure.

Les composants NA (Not Available) ne sont pas disponibles en pièce de rechange.

DEUTSCH

TYP :

S = Ersatzteile

W = Verschleißteile

NA = nicht verfügbare

Die definierten Ersatzteil-Set's beinhalten alle Ersatzteile wie Komponenten, Schrauben, Muttern etc.

Norm- bzw. Standardteile wie Schrauben, Muttern etc. können bei offiziellen Schrauben- sowie Komponentenhändler bezogen werden.

Alle Norm- bzw. Standardteile wie Schrauben, Muttern etc. entsprechen der Qualitäts- bzw. Festigungsklasse 8.8.

Wir empfehlen, keine Norm- bzw. Standardteile wie Schrauben, Muttern etc. unter der Qualitäts- bzw.

Festigungsklasse 8.8 einzusetzen.

Es dürfen nur geprüfte Norton CLIPPER-Ersatzteile eingesetzt werden.

Die Lebensdauer der Verschleißteile hängt von der Verwendung und Wartung der Maschine oder des Teils ab. Verschleißteile müssen gewartet und bei Bedarf ersetzt werden. Für Verschleißteile wird keine Garantie übernommen.

Ersatzteile sowie Komponenten mit dem Vermerk NA (NA=nicht verfügbar) sind nicht verfügbar.

Main frame / Châssis principal / Rahmen

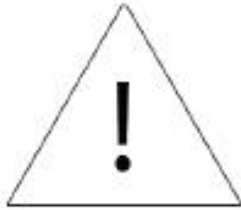

Depends on the serial number of the machine
 Dépend du numéro de serie de la machine
 Hängt von der Nummer von Serie der Maschine ab

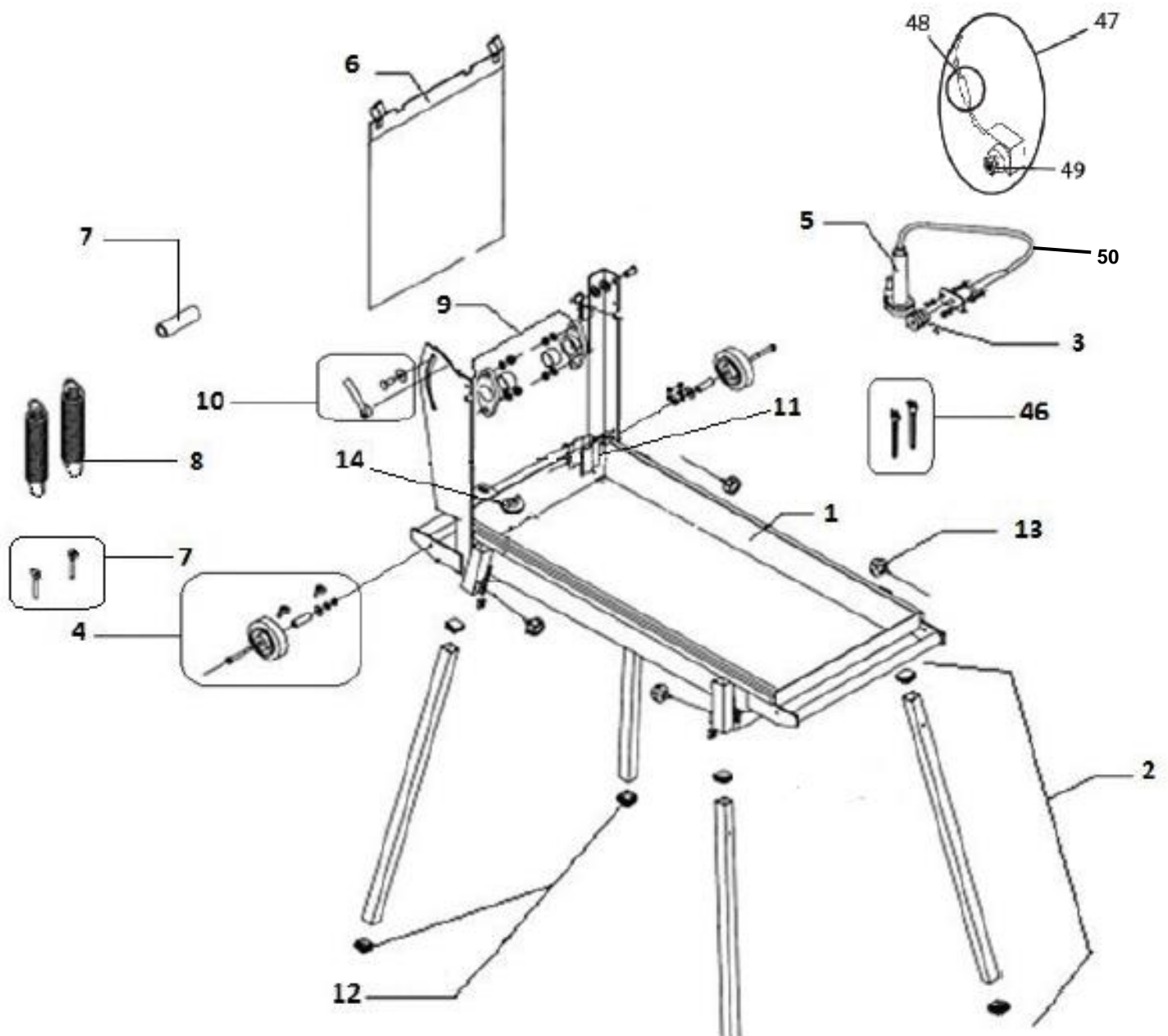

POS.	DESCRIPTION	DESCRIPTION	BESCHREIBUNG	QTY	REF	TYPE
1	Welded frame	Châssis soudé	Geschweißter Rahmen	1	310369636	S
2	Foot kit	Kit pied	Füße Satz	1	310486423	S
	Foot	Pied	Fuß	1		
	Square plug	Bouchon carré	Viereckiger Deckel	2		
4	Wheel complete	Roue complète	Rad, Kompl.	1	310012190	S
	Wheel	Roue	Rad	1		
	Spacer	Entretoise	Strebe	1		
	screw DIN 933 – M8X65	vis DIN 933 – M8X65	Schraube DIN 933 – M8X65	1		
	washer DIN 125 - A8,4	rondelle DIN 125 - A8,4	Scheibe DIN 125 - A8,4	1		
	washer DIN 9021 - Ø8	rondelle DIN 9021 - Ø8	Scheibe DIN 9021 - Ø8	1		
	nut DIN 985 - M8	ecrou DIN 985 - M8	Mutter DIN 985 - M8	1		
3	Water pump pulley	Poulie pompe à eau	Wasserpumperolle	1	310004669	S
	Pulley	Poulie	Rolle	1		
	screw DIN916 - M6x12	vis DIN916 - M6x12	Schraube DIN 916 - M6X12	1		
5	Waterpump kit (up to 161255080)	Kit pompe à eau (jusqu'à 161255080)	Wasserpumpe Satz	1	310004237	W
	Waterpump	Pompe à eau	Wasserpumpe	1		
	screw DIN 933 – M6X20	vis DIN 933 – M6X20	Schraube DIN 933 – M6X20	2		
	washer DIN 125 - A6,3	rondelle DIN 125 - A6,3	Scheibe DIN 125 - A6,3	4		
	nut DIN 985 - M6	ecrou DIN 985 - M6	Mutter DIN 985 - M6	2		
47	Water pump assy. 115V kit (from 161255080)	Kit pompe complète 115V (depuis 161255080)	Wasserpumpe Satz 115V (Serien Nr. von 161255080)	1	310459733	S
	Water pump assy. 230V kit (from 161255080)	Kit pompe complète 230V (depuis 161255080)	Wasserpumpe Satz 230V (Serien Nr. von 161255080)	1	310446803	S
	Male connector	Connecteur mâle	Stecker (männlich.)	1		
	Female connector	Connecteur femelle	Stecker (Weiblich.)	1		
	Water pump 220V	Pompe complète 220V	Wasserpumpenzus.	1		
48	Powersafe Plug	Connecteur électrique étanche	Wasserdichte Steckverbindung	1	510109120	S
	Male connector	Connecteur mâle	Stecker (männlich.)	1		
	Female connector	Connecteur femelle	Stecker (Weiblich.)	1		
49	Pump suction parts P2	pièces d'aspiration pompe P2	Pumpensaugöffnung Teile P2	1	310007222	W
	Pump suction parts G-MD108 and GD 108	pièces d'aspiration pompe G-MD108 et GD 108	Pumpensaugöffnung Teile G-MD108 und GD 108	1	310529541	W
	Pump suction parts FA 180	pièces d'aspiration pompe FA 180	Pumpensaugöffnung Teile FA 180	1	310531889	W

Main frame / Châssis principal / Rahmen

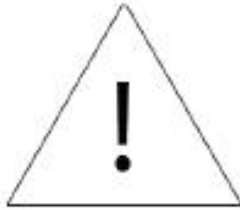

Depends on the serial number of the machine
 Dépend du numéro de serie de la machine
 Hängt von der Nummer von Serie der Maschine ab

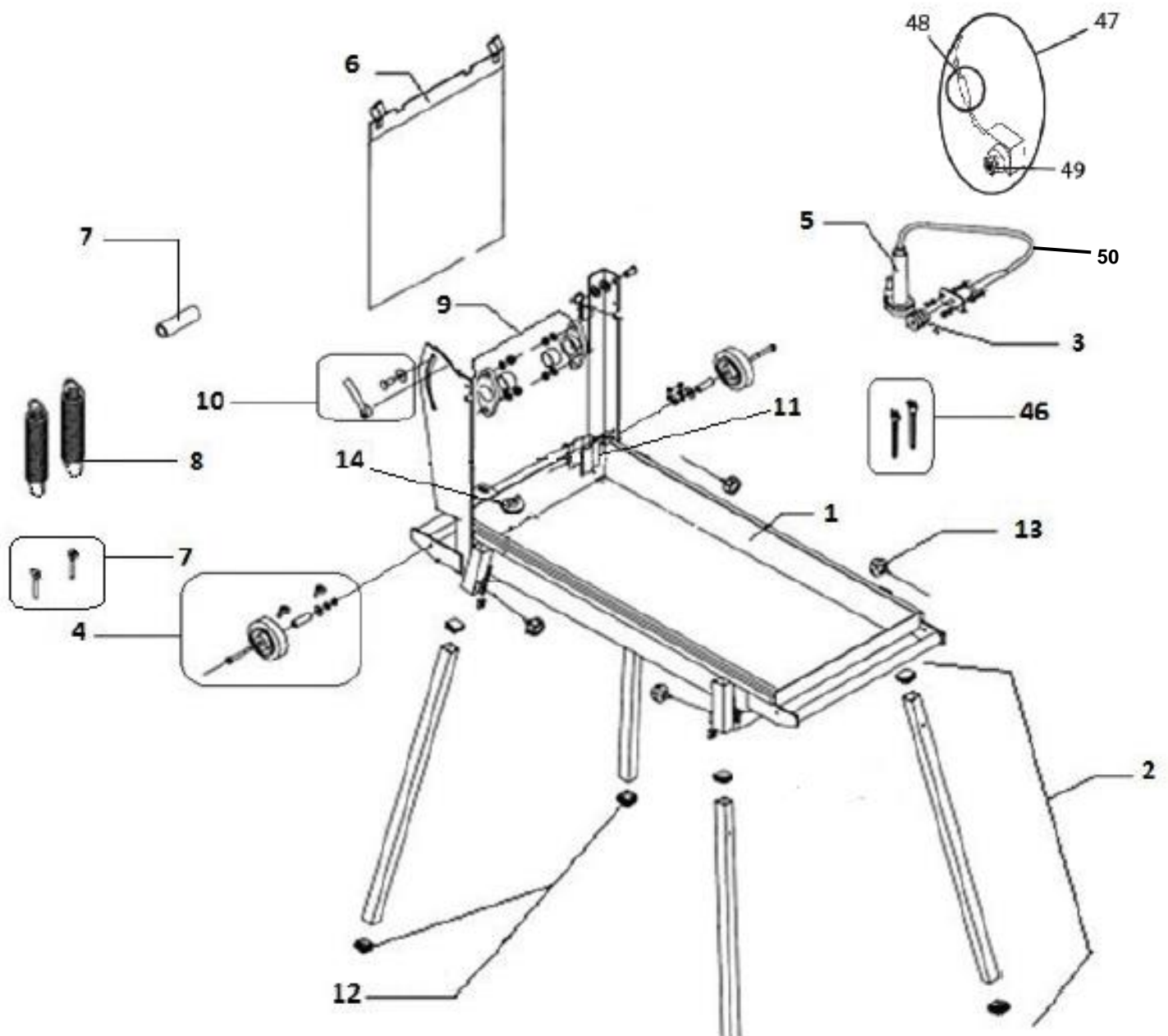

POS.	DESCRIPTION	DESCRIPTION	BESCHREIBUNG	QTY	REF	TYPE
6	Splash guard kit	Kit rideau d'eau	Wasservorhangträger, Kompl.	1	310004633	W
	Splash guard	Rideau d'eau	Wasservorhangträger	1		
	Retaining spring	Ressort de retenue	Haltefeder	4		
	Rivet A 4X7X9 DIN7331	Rivet A 4X7X9 DIN7331	Niet A 4X7X9 DIN7331	4		
7	Spring fixing kit	Kit fixation ressort	Befestigungsfeder Satz	1	510103527	S
	screw DIN 444 – M8X100	vis DIN 444 – M8X100	Schraube DIN 444 – M8X100	1		
	Tube	Tube	Rohr	1		
8	Spring	Ressort	Feder	1	310004305	S
9	Complete bearing kit	Kit palier complet	Lager Satz, Kompl.	1	310007349	W
	Bearing	Palier	Lager	2		
	screw DIN 933 – M10X35	vis DIN 933 – M10X35	Schraube DIN 933 – M10X35	4		
	washer DIN 125 - A10,5	rondelle DIN 125 - A10,5	Scheibe DIN 125 - A10,5	8		
	nut DIN 985 - M10	ecrou DIN 985 - M10	Mutter DIN 985 - M10	4		
10	Locking handle M12	Kit poignée indexable	M12 Blockierhandgriff	1	310006528	S
	Handle M12	Poignée M12	M12 Handgriff	1		
	washer DIN 9021 - A13	rondelle DIN 9021 - A13	Scheibe DIN 9021 - A13	1		
	screw DIN 603 – M12X45	vis DIN 603 – M12X45	Schraube DIN 603 – M12X45	1		
	washer DIN 125 - A12	rondelle DIN 125 - A12	Scheibe DIN 125 - A12	1		
	washer DIN 125 - A17	rondelle DIN 125 - A17	Scheibe DIN 125 - A17	1		
	washer DIN 127 - A12	rondelle DIN 127 - A12	Scheibe DIN 127 - A12	1		
	nut DIN 934 - M12	ecrou DIN 934 - M12	Mutter DIN 934 - M12	1		
11	Holder complete	Kit de support inférieur de pompe	Wasserpumpe Träger	1	310004778	S
	Holder	Support	Träger	1		
	screw DIN 933 – M6X35	vis DIN 933 – M6X35	Schraube DIN 933 – M6X35	2		
	washer DIN 125 - A6,3	rondelle DIN 125 - A6,3	Scheibe DIN 125 - A6,3	6		
	nut DIN 985 - M6	ecrou DIN 985 - M6	Mutter DIN 985 - M6	2		
	Spacer 15x2x10	Entretoise 15x2x10	Strebe 15x2x10	2		
12	Tube cap	Bouchon tube carré	Viereckiger Deckel	8	510103529	S
13	Knob M10X20	Bouton fileté M10X20	M10x20 Schraubenbolzens	1	310004345	S
14	Plug	Bouchon	Deckel	1	310004776	S
	Cap	Bouchon	Deckel	1		
	Chain	Chaine	Kette	1		
	screw eyelet ST 2,9x20	Piton a visser ST 2,9x20	ST 2,9x20 Ring- und ÖsenSchrauben	1		
	screw DIN 933 - M6x20	vis DIN 933 - M6x20	Schraube DIN 933 - M6x20	1		
	washer DIN125 - A6,4	rondelle DIN125 - A6,4	Scheibe DIN125 - A6,4	2		
	nut DIN985 - M6	ecrou DIN985 - M6	Mutter DIN985 - M6	1		
46	Tools kit	Kit outils	Werkzeug-Satz	1	310486424	S
	Wrench 22mm	Clé 22mm	Maulschlüssel 22mm	1		
	Wrench 19mm	Clé 19mm	Maulschlüssel 19mm	1		
50	Flexible shaft cpl. for mech pump	Flexible de pompe mécanique	biegsame Welle	1	310004238	W

Blade guard / Carter de disque / Plattegehäuse

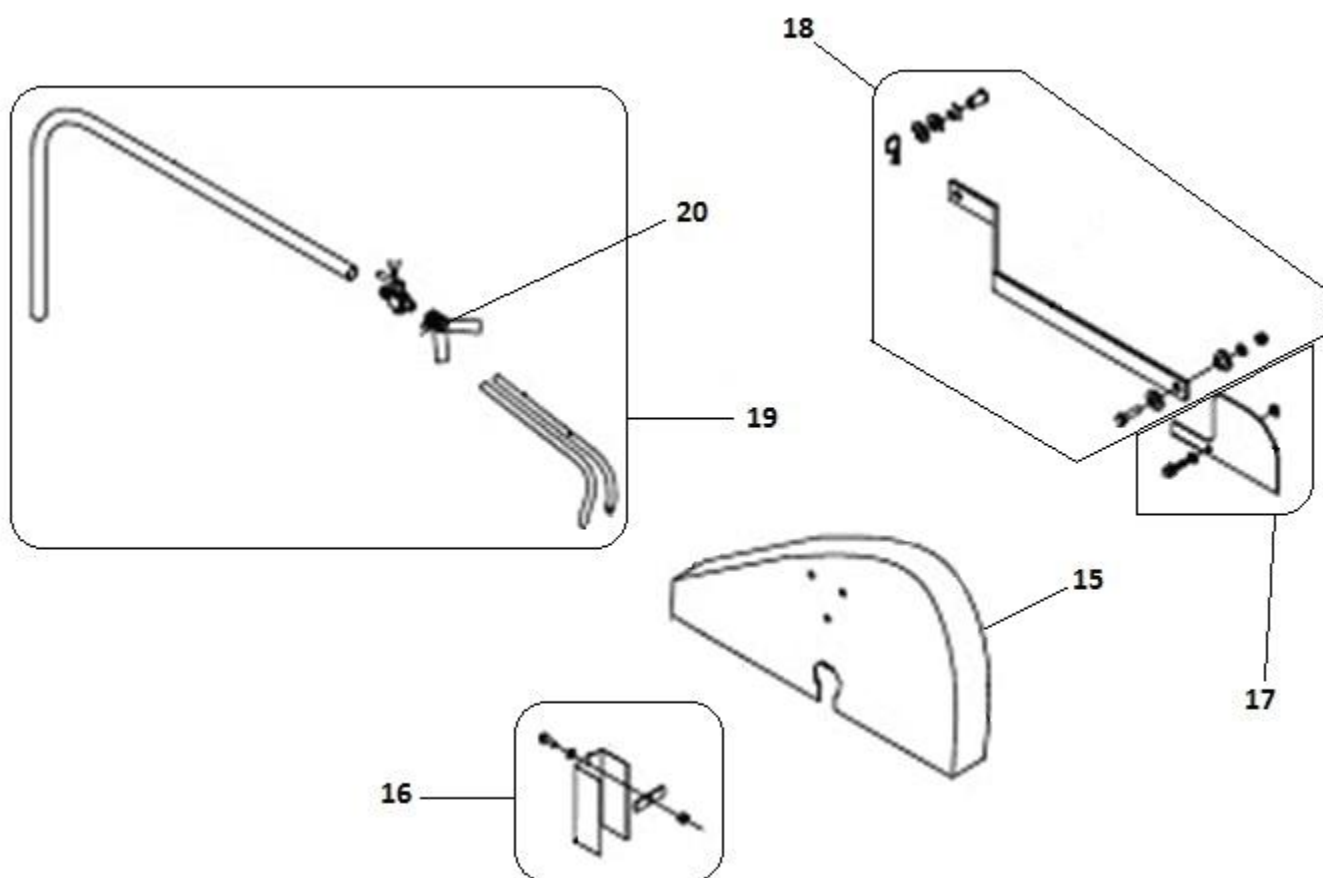

POS.	DESCRIPTION	DESCRIPTION	BESCHREIBUNG	QTY	REF	TYPE
15	Blade guard welded	Carter de lame soudé	Geschweißtes Messergehäuse	1	310369611	S
	Blade guard	Carter de lame	Messergehäuse	1		
	screw DIN 933 – M8X20	vis DIN 933 – M8X20	Schraube DIN 933 – M8X20	3		
	washer DIN 125 - A8,4	rondelle DIN 125 - A8,4	Scheibe DIN 125 - A8,4	3		
	washer DIN 127 - M8	rondelle DIN 127 - W8,4	Scheibe DIN 127 - M8	3		
16	Water curtain kit	Kit bavette	Spritzlappen Satz	1	310004413	W
	Water curtain	Bavette	Spritzlappen	1		
	screw DIN 933 – M6X20	vis DIN 933 – M6X20	Schraube DIN 7380 – M6X20	1		
	washer DIN 125 - A6,3	rondelle DIN 125 - A6,3	Scheibe DIN 125 - A6,3	1		
	nut DIN 985 - M6	ecrou DIN 985 - M6	Mutter DIN 985 - M6	1		
	Plate	Plaque	Platte	1		
17	Closing plate of blade guard	Kit fermeture carter de disque	Verschlußblech des Messergehäuse	1	310004790	S
	Closing plate	Tôle de fermeture	Verschlußblech	1		
	screw DIN 933 – M8X20	vis DIN 933 – M8X20	Schraube DIN 933 – M8X20	1		
	washer DIN 125 - A8,4	rondelle DIN 125 - A8,4	Scheibe DIN 125 - A8,4	2		
	nut DIN 985 - M8	ecrou DIN 985 - M8	Mutter DIN 985 - M8	1		
18	Arm complete	Bras de renvoi complet	Rückhebelarm Satz	1	510103531	S
	Arm	Bras de renvoi	Hebelarm	1		
	screw DIN 933 – M8X35	vis DIN 933 –M8X35	Schraube DIN 933 – M8X35	1		
	washer DIN 125 -A8,4	rondelle DIN 125 - A8,4	Scheibe DIN 125 -A8,4	2		
	eccentric nut	ecrou excentrique	exzentrische Mutter	1		
	nut DIN 985 - M8	ecrou DIN 985 - M8	Mutter DIN 985 - M8	1		
	PIN DIN 11024 - 4mm	GOUPILLE DIN 11024 - 4mm	Stift DIN 11024 - 4mm	1		
	washer DIN 125 - A14	rondelle DIN 125 - A14	Scheibe DIN 125 - A14	2		
	Pin DIN 1434 - Ø13x25mm	Rivet DIN 1434 - Ø13x25mm	Niet DIN 1434 - Ø13x25mm	1		
19	Watering system assy.	Système d'arrosage complet	Bewässerungssystem, Kompl.	1	510104923	S
	Y connector assy.	Connecteur Y comp.	Kompletter "Y" Verbinder	1		
	Watering nozzle	Busette d'arrosage	Sprühdüse	2		
	Water pipe	Tuyau d'eau	Wasserschlauch	1		
	Gate valve	Robinet	Wasserhahn	1		
20	Y connector assy.	Connecteur Y comp.	"Y" Verbinder, Kompl.	1	510114596	S

Cutting head / Tête de coupe / Schüsselkopf

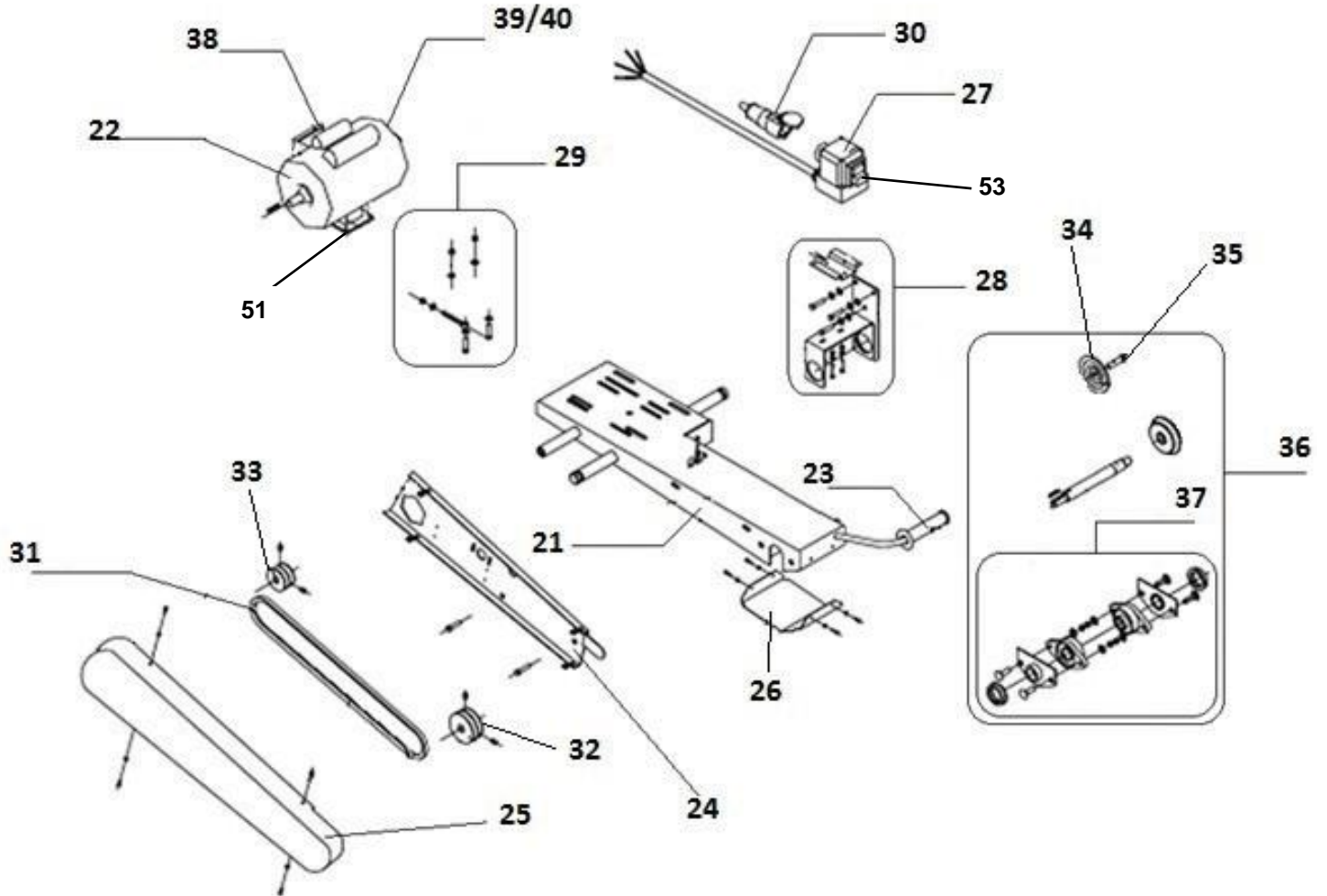

POS.	DESCRIPTION	DESCRIPTION	BESCHREIBUNG	QTY	REF	TYPE
21	Head of cut	Tête de coupe	Schneidkopf	1	310369721	S
23	Handle	Poignée en caoutchouc	Handgriff	1	310004190	S
24	Fixed cover	Carter fixe	Festes Gehäuse	1	310369615	S
	Fixed cover	Carter fixe	Festes Gehäuse	1		
	screw DIN 933 – M10X25	vis DIN 933 – M10X25	Schraube DIN 933 – M10X25	2		
	washer DIN 125 - A10,5	rondelle DIN 125 - A10,5	Scheibe DIN 125 - A10,5	4		
	nut DIN 985 - M10	ecrou DIN 985 - M10	Mutter DIN 985 - M10	2		
25	Mobile cover	Carter mobile	bewegliches Gehäuse	1	310369618	S
	Mobile cover	Carter mobile	bewegliches Gehäuse	1		
	flange screw DIN 933 – M4X16	vis à tête bridée DIN 933 – M4X16	Schlitzschraube DIN 933 – M4X16	4		
26	Protection plate of bearing	Kit protection paliers	Lager Schützblech	1	310004792	S
	Protection plate	Tôle de protection	Schützblech	1		
	flange screw DIN 933 – M4X16	vis à tête bridée DIN 933 – M4X16	Schlitzschraube DIN 933 – M4X16	4		
27	Switch 230V	Interrupteur 230V	Schalter 230V	1	310369467	S
	Switch	Interrupteur	Schalter	1		
	Cable	Cable	Kabel	1		
	screw DIN 7985 – M5X55	vis DIN 7985 – M5X55	Schraube DIN 7985 – M5X55	2		
	washer DIN 125 - A5,3	rondelle DIN 125 - A5,3	Scheibe DIN 125 - A5,3	2		
	nut DIN 985 - M5	ecrou DIN 985 - M5	Mutter DIN 985 - M5	2		
28	Holder arm	Support bras de renvoi	Hebelarmträger	1	510111728	S
	fixing plate	plaque de fixation	Befestigungsplatte	1		
	screw DIN 933 M6X20	vis DIN 933 M6X20	Schraube DIN 933 M6X20	2		
	washer DIN 125 A6,4	rondelle DIN 125 A6,4	Scheibe DIN 125 A6,4	4		
	nut DIN 985 M6	ecrou DIN 985 M6	Mutter DIN 985 M6	2		
29	Kit belt tensioner	Kit tendeur de courroies	Riemenspanner Satz	1	510103533	S
	screw DIN 444 – M8X60	vis DIN 444 – M8X60	Schraube DIN 444 – M8X60	2		
	screw DIN 444 – M8X30	vis DIN 444 – M8X30	Schraube DIN 444 – M8X30	2		
	washer DIN 125 - A8,4	rondelle DIN 125 - A8,4	Scheibe DIN 125 - A8,4	4		
	nut DIN 934 - M8	ecrou DIN 934 - M8	Mutter DIN 934 - M8	2		
	nut DIN 439 - M8	ecrou DIN 439 - M8	Mutter DIN 439 - M8	2		
	nut DIN 985 - M8	ecrou DIN 985 - M8	Mutter DIN 985 - M8	4		
30	Plug	Prise femelle	Steckdose (weibliches Teil)	1	510103453	S
31	Belt	Courroie	Riemen	1	310369466	W
32	Blade pulley	Poulie arbre de meule	Schleifscheibenachse Rolle	1	310004779	S
	Pulley	Poulie	Rolle	1		
	screw DIN 916 - M8X12	vis DIN 916 - M8X12	Schraube DIN 916 - M8X12	2		
	Key DIN 6885 - A5x5x40	Clavette DIN 6885 - A5x5x40	Keil DIN 6885 - A5x5x40	1		
33	Motor pulley kit	Kit poulie moteur	Motorrolle Satz	1	310369613	S
	Motor pulley	Poulie moteur	Motorrolle	1		
	screw DIN 916 - M8X12	vis DIN 916 - M8X12	Schraube DIN 916 - M8X12	2		
	Key DIN 6885 - A8x7x45	Clavette DIN 6885 - A8x7x45	Keil DIN 6885 - A8x7x45	1		
34	Flange mobile	Flasque mobile	Bewelische Flansche	1	310004410	S
35	screw	vis de serrage	Klemmschraube	1	510005306	S
53	Cap for termical protection	Capuchon de protection thermique	Hitzeschild	1	310005072	S

Cutting head / Tête de coupe / Schüsselkopf

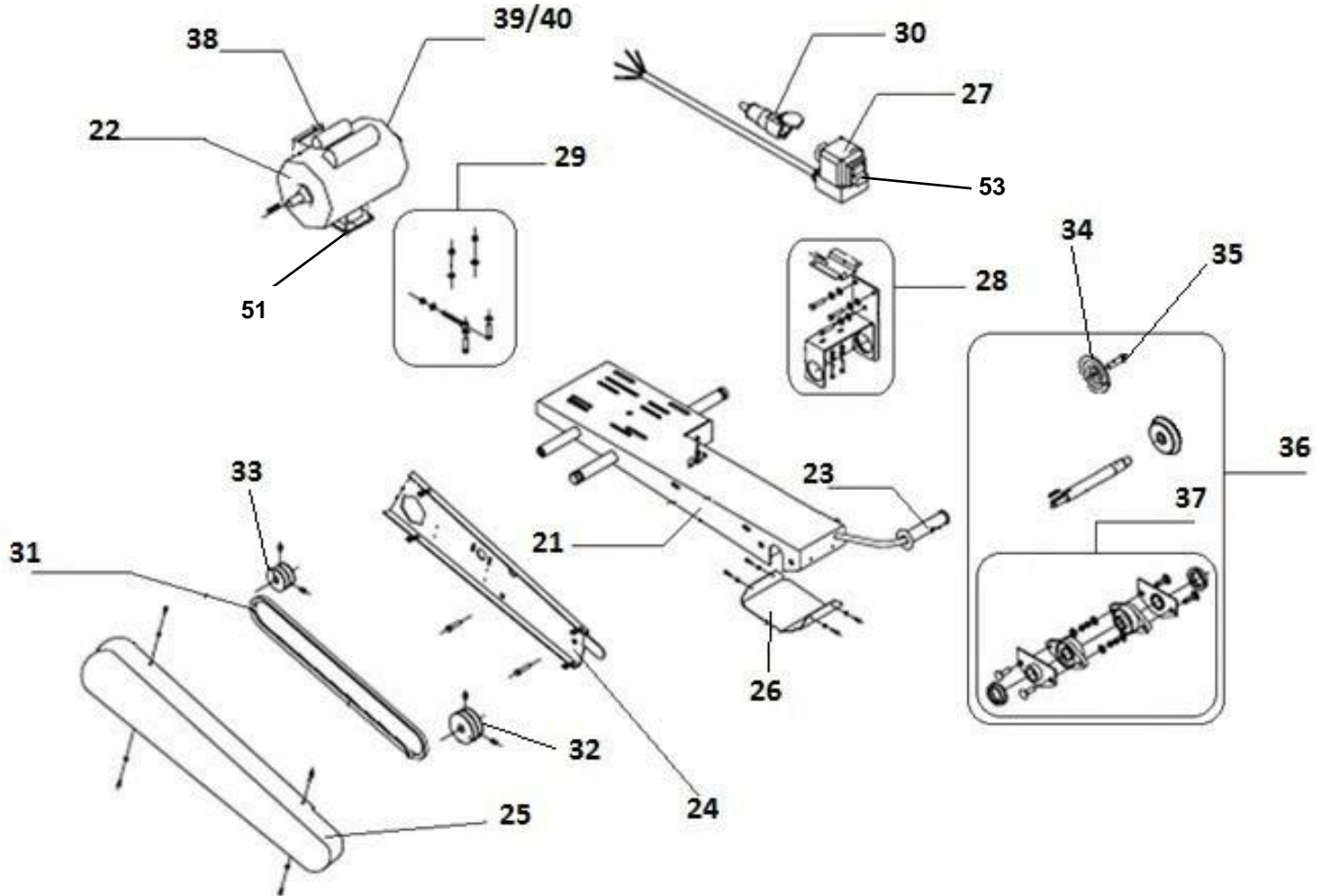

POS.	DESCRIPTION	DESCRIPTION	BESCHREIBUNG	QTY	REF	TYPE
36	Blade shaft complete	Arbre de meule complet	Schleifscheibenachse, Kompl.	1	510111769	S
	Blade shaft	Arbre de meule	Schleifscheibenachse	1		
	Fixed flange	Flasque fixe	Feste Flansche	1		
	Mobile flange	Flasque mobile	Bewelische Flansche	1		
	screw	vis de serrage	Klemmschraube	1		
	Bearing	Paliers	Lager	2		
	Spacer	Entretoise	Strebe	4		
	screw DIN 603 – M10X35	vis DIN 603 – M10X35	Schraube DIN 603 – M10X35	4		
	washer DIN125 - A10,5	rondelle DIN125 - A10,5	Scheibe DIN125 - A10,5	4		
	nut DIN 985 - M10	ecrou DIN 985 - M10	Mutter DIN 985 - M10	4		
37	Kit complete bearing (set of 2)	Kit palier complet (jeu de 2)	Lager Satz, Kompl. (Satz von 2 Stk)	1	510103545	W
	Blade shaft bearing	Palier arbre de meule	Schleifscheibenachse Lager	2		
	screw DIN 603 – M10X35	vis DIN 603 – M10X35	Schraube DIN 603 – M10X35	4		
	washer DIN125 - A10,5	rondelle DIN125 - A10,5	Scheibe DIN125 - A10,5	4		
	nut DIN 985 - M10	ecrou DIN 985 - M10	Mutter DIN 985 - M10	4		

Moteur Able

POS.	DESCRIPTION	DESCRIPTION	BESCHREIBUNG	QTY	REF	TYPE
22	Motor 230V MOTOR ABLE	Moteur 230V MOTEUR ABLE	Motor 230V MOTOR ABLE	1	510133164	S
38	Connecting box MOTOR ABLE	Boite à bornes MOTEUR ABLE	Klemmenblock MOTOR ABLE (Serien Num bis 1611....)	1	510133165	S
39	Motor fan MOTOR ABLE	Ventilateur moteur MOTEUR ABLE	Ventilator Motor MOTOR ABLE	1	510133166	S
41	Condensator MOTEUR ABLE for dephasing only (Serial Nbr from 1611....) 1 of 80µF or 2 of 40µF in parallel	Condensateur MOTEUR ABLE pour le déphasage uniquement (N° série à partir de 1611....) 1 de 80µF ou 2 de 40µF en parallèle	Kondensator MOTEUR ABLE nur für Phasenwinkel (Serien Num bis 1611....) 1 von 80µF oder 2 von 40µF parallellaufend	1	510137240	S
40	Cover fan MOTOR ABLE	Capot ventilateur MOTEUR ABLE	Motordeckel MOTOR ABLE	1	510133168	S
51	Engine feet Able	Pieds de moteurs Able	Motorfüße Able	2	310533083	S

Moteur Leroy

POS.	DESCRIPTION	DESCRIPTION	BESCHREIBUNG	QTY	REF	TYPE
22	Motor 230V MOTOR LEROY SOMER	Moteur 230V MOTEUR LEROY SOMER	Motor 230V MOTOR LEROY SOMER	1	510003842	S
38	Connecting box MOTOR LEROY SOMER	Boite à bornes MOTEUR LEROY SOMER	Klemmenblock MOTOR LEROY SOMER	1	310379220	S
39	Motor fan MOTOR LEROY SOMER	Ventilateur moteur MOTEUR LEROY SOMER	Ventilator Motor MOTOR LEROY SOMER	1	310379223	S
41	Condensator MOTOR LEROY SOMER (Serial Nbr from 1111... to 1611....) 40µF for phasing	Condensateur MOTOR LEROY SOMER (N° série de 1111... à 1611....) 40µF pour le phasage	Kondensator MOTOR LEROY SOMER (Serien Num von 1111... bis 1611....) 40 µF für Phasen	1	510137444	S
40	Cover fan MOTOR LEROY SOMER	Capot ventilateur MOTEUR LEROY SOMER	Ventilator Deckel MOTOR LEROY SOMER	1	310379224	S

Table / Table / Tisch

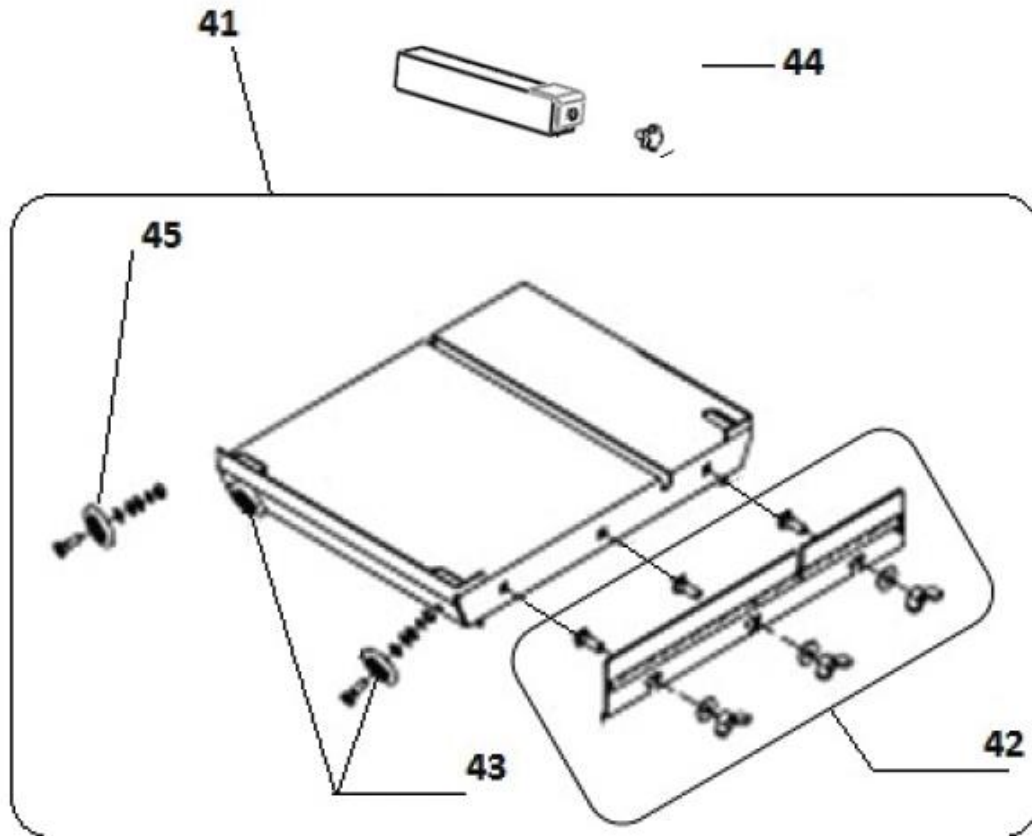

POS.	DESCRIPTION	DESCRIPTION	BESCHREIBUNG	QTY	REF	TYPE
41	Cutting table	Table de coupe	Zuschneidetisch	1	310486273	S
	Table	Table	Tisch	1		
	Material stop complete	Butée matériau complète	Baustoffanschlag Satz	1		
	screw DIN 603 – M10X35	vis DIN 603 – M10X35	Schraube DIN 603 M10x30	3		
	washer DIN125 - A10,5	rondelle DIN125 - A10,5	Scheibe DIN 125 - A10,5	3		
	washer DIN125 - A13	rondelle DIN125 - A13	Scheibe DIN 125 - A13	3		
	nut DIN 985 - M10	ecrou DIN 985 - M10	Mutter DIN 315 M10	3		
	Wheels	Roulettes	Rolle	5		
	screw NFE 21003 – M8X28	vis NFE 21003 – M8X28	Schraube NFE 21003 – M8X28	5		
	washer DIN 125 - A8,4	rondelle DIN 125 - A8,4	Scheibe DIN 125 - A8,4	15		
	washer DIN 125 - A10,5	rondelle DIN 125 - A10,5	Scheibe DIN 125 - A10,5	5		
	nut DIN 985 - M8	ecrou DIN 985 - M8	Mutter DIN 985 - M8	5		
42	Material stop complete	Butée matériau complète	Baustoffanschlag Satz	1	510103546	S
	Material stop	Butée matériau	Baustoffanschlag	1		
	Ruler	Règlette	Regel	1		
	Rivet	Rivet	Niet	5		
	screw DIN 603 – M10X35	vis DIN 603 – M10X35	Schraube DIN 603 M10x30	3		
	washer DIN125 - A10,5	rondelle DIN125 - A10,5	Scheibe DIN 125 - A10,5	3		
	washer DIN125 - A13	rondelle DIN125 - A13	Scheibe DIN 125 - A13	3		
	nut DIN 985 - M10	ecrou DIN 985 - M10	Mutter DIN 315 M10	3		
43	Wheels (set of 4)	Roulette (jeu de 4)	Rolle (Satz von 4)	1	310004676	W
	Wheels	Roulettes	Rolle	4		
	screw NFE 21003 – M8X28	vis NFE 21003 – M8X28	Schraube NFE 21003 – M8X28	4		
	washer DIN 125 - A8,4	rondelle DIN 125 - A8,4	Scheibe DIN 125 - A8,4	12		
	washer DIN 125 - A10,5	rondelle DIN 125 - A10,5	Scheibe DIN 125 - A10,5	4		
	nut DIN 985 - M8	ecrou DIN 985 - M8	Mutter DIN 985 - M8	4		
44	Guide of cut	Guide de coupe	Schneidführung	1	310007501	S
45	Anti pivoting system	Systeme anti-basculement	Stabilisierungssystem	1	310002332	S
	screw DIN 603 M10x30	vis DIN 603 M10x30	Schraube DIN 603 M10x30	2		
	washer DIN 125 - A13	rondelle DIN 125 - A13	Scheibe DIN 125 - A13	2		
	washer DIN 125 - A10,5	rondelle DIN 125 - A10,5	Scheibe DIN 125 - A10,5	2		
	nut DIN 315 M10	ecrou DIN 315 M10	Condensa	2		
	Wheel	Roulette	Rolle	1		
	screw NFE 21003 – M8X28	vis NFE 21003 – M8X28	Schraube NFE 21003 – M8X28	1		
	washer DIN 125 - A8,4	rondelle DIN 125 - A8,4	Scheibe DIN 125 - A8,4	3		
	washer DIN 125 - A10,5	rondelle DIN 125 - A10,5	Scheibe DIN 125 - A10,5	1		
	nut DIN 985 - M8	ecrou DIN 985 - M8	Mutter DIN 985 - M8	1		

POS.	DESCRIPTION	DESCRIPTION	BESCHREIBUNG	QTY	REF	TYPE
52	Sticker kit	Kit d'autocollants	Aufkleber Satz	1	510141471	S
	White arrow	Flèche blanche	Weißer Pfeil	1		
	4 pictograms	4 pictogrammes	4 Piktogramme	1		
	Left side	Flanc gauche	Linke Flanke	1		
	Right side	Flanc droit	Rechte Flanke	1		
	Norton Clipper Logo Blade guard	Norton Clipper carter de disque	Norton Clipper Scheibehäuse	1		
	Risk of hand cut	Risque de coupure main	Gefahr von Schnittverletzungen	1		
	Norton Clipper Logo Blade guard back	Norton Clipper carter de disque arrière	Norton Clipper Hinterplattegehäuse	1		
	Logo 3 bands	Logo 3 bandes	3 Bänder Logo	1		

SAINT-GOBAIN ABRASIVES
 INDUSTRIEWEG 21
 9420 ERPE-MERE
 BELGIUM
 TEL: +32(0) 2 267 21 00

SAINT-GOBAIN CONSTRUCTION
 PRODUCTS CZ A.S
 DIVIZE ABRASIVES
 SMRČKOVA 2485/4
 180 00 PRAHA 8
 CZECH REPUBLIC
 TEL: +420 255 719 326
 FAX: +420 255 719 321

SAINT-GOBAIN ABRASIVES A/S
 DYBENDALSVÆNGET 2,
 DK-2630 TAASTRUP
 DENMARK
 TEL: +45 4675 5244

PO BOX 643706
 FORTUNE TOWER OFFICE 2106
 JLT BLOCK C
 (NEXT TO METRO STATION)
 JUMEIRA LAKE TOWER, DUBAI
 UNITED ARAB EMIRATES
 TEL: +971 4 431 5154
 FAX: +971 4 431 5434

SAINT-GOBAIN ABRASIFS
 RUE DE L'AMBASSADEUR - B.P.8
 78 702 CONFLANS CEDEX
 FRANCE
 TEL: +33 (0)1 34 90 40 00
 FAX: +33 (0)1 39 19 89 56

SAINT-GOBAIN ABRASIVES GMBH
 BIRKENSTRASSE 45-49
 D-50389 WESSELING
 GERMANY
 TEL: +49 (0) 2236 703-0
 FAX: +49 (0) 2236 703-730

SAINT-GOBAIN ABRASIVES KFT.
 1225 BUDAPEST
 BÁNYALÉG U. 60/B.
 HUNGARY
 TEL: +36 1 371 22 50
 FAX: +36 1 371 22 55

SAINT-GOBAIN ABRASIVI S.P.A
 VIA PER CESANO BOSCONI 4
 I-20094 CORSICO MILANO
 ITALY
 TEL: +39 02 44 851
 FAX: +39 02 44 78 266

SAINT-GOBAIN ABRASIVES S.A.
 190 RUE J.F. KENNEDY
 L-4930 BASCHARAGE
 GRAND DUCHE DE LUXEMBOURG
 TEL: +352 50 401 1
 FAX: +331 83 717 792
 NO. VERT (FRANCE): 0800 906 903

SAINT-GOBAIN ABRASIFS, S.A.
 2 ALLÉE DES FIGUIERS
 AIN SEBAË - CASABLANCA
 MOROCCO
 TEL: +212 5 22 66 57 31
 FAX: +212 5 22 35 09 65

SAINT-GOBAIN ABRASIVES BV
 GROENLOSEWEG 28
 7151 HW EIBERGEN
 P.O. BOX 10
 7150 AA EIBERGEN
 THE NETHERLANDS
 TEL: +31 545 466466
 FAX: +31 545 474605

SAINT-GOBAIN ABRASIVES AS
 KARIHAUGVEIEN, 89
 0186 OSLO
 NORWAY
 TEL: +47 63 87 06 00
 FAX: +47 63 87 06 01

SAINT-GOBAIN HPM POLSKA SP. Z O.O.
 UL. NORTON 1, 62-600 KOŁO
 62-600 KOŁO
 POLAND
 TEL: +48 63 26 17 100
 FAX: +48 63 27 20 401

SAINT-GOBAIN ABRASIVOS, L. DA
 ZONA INDUSTRIAL DA MAIA
 I-SECTOR VIII, NO. 122
 APARTADO 6050
 4476 - 908 MAIA
 PORTUGAL
 TEL: +351 229 437 940
 FAX: +351 229 437 949

SAINT-GOBAIN GLASS
 BUSINESS UNIT ABRASIVI
 PUNCT DE LUCRU : LOC.VETIS, JUD.
 SATU MARE 447355
 STR. CAREIULUI 11
 PARC INDUSTRIAL RENOVATIO
 ROMANIA
 TEL: +40 261 839 709
 FAX: +40 261 839 710

SG HPM RUS
 58, F. ENGELS STR.
 STROENIE 2
 105082 MOSCOW
 RUSSIA
 TEL: +74 955 408 355
 FAX: +74 959 373 224

SAINT-GOBAIN
 ABRASIVES (PTY) LTD
 2 MONTEER ROAD
 ISANDO 1600
 P.O. BOX 67
 SOUTH AFRICA
 TEL: +27 11 961 2000
 FAX: +27 11 961 2184/5

SAINT-GOBAIN ABRASIVOS, S.A.
 CTRA. DE GUIPÚZCOA, KM. 7,5
 E-31195 BERRIOPLANO (NAVARRA)
 SPAIN
 TEL: +34 948 306 000
 FAX: +34 948 306 042

SAINT GOBAIN ABRASIVES AB
 GÅRDSFOGDEVÄGEN 18A
 168 66 BROMMA • SVERIGE
 SWEDEN
 TEL: +46 8 580 881 00
 FAX: +46 8 580 881 30

SAINT-GOBAIN INOVATIF MALZEMELER
 VE ASINDIRICI SAN. TIC. AS.
 ALTAYÇEŞME MAH. ÇAMLI SOK. NO:21
 ESAS OFISPARK KAT:9 34843
 MALTEPE, İSTANBUL • TURKEY
 TEL: 0090-216-217 12 50
 FAX: 0090-216-442 40 74

SAINT-GOBAIN ABRASIVES LTD.
 UNICORN HOUSE UNIT 1, AMISON CLOSE
 REDHILL BUSINESS PARK
 STAFFORD ST161WB
 UNITED KINGDOM
 TEL: +44 1785 279 553
 FAX: +44 1785 213 487



Saint-Gobain Abrasifs
 190 Rue J.F. Kennedy
 L-4930 Bascharage
 Grand Duche de Luxembourg
 Tel: +352 50 401 1
 Fax: +331 83 717 792
 no. vert (France) 0800 906 903