

CGW

OPERATING INSTRUCTIONS

Translation of the original instructions



SAINT-GOBAIN

clipper[®]



CE Declaration of conformity

The undersigned manufacturer:

SAINT - GOBAIN ABRASIVES S.A.
190, BD J.F. KENNEDY
L- 4930 BASCHARAGE

Declares that this product:

Masonry Saws: **CGW 230V**
CGW 115V

Code: **70184629851**
70184630481

is in conformity with the following Directives:

- **"MACHINES" 2006/42/CE**
- **"ÉLECTROMAGNÉTIQUE COMPATIBILITÉ" 2014/30/UE**
- **"NOISE" 2000/14/CE**

and European standard:

- **EN 12418 – Masonry and stone cutting-off machines – Safety**

Valid for machines as of serial number:

4500000000

Storage site for the technical documents:

Saint-Gobain Abrasives 190, Bd. J. F. Kennedy 4930 BASCHARAGE, LUXEMBOURG

This declaration of conformity loses its validity when the product is converted or modified without agreement.

Bascharage, 14.03.2023.

François Chianese, executive officer and responsible for the technical file.
Bascharage, Luxembourg.



**UK
CA**

SAINT-GOBAIN

Declaration of conformity

The undersigned manufacturer:

SAINT - GOBAIN ABRASIVES S.A.
190, BD J.F. KENNEDY
L- 4930 BASCHARAGE

Declares that this product:

Masonry Saw: **CGW 230V**
CGW 115V

Code: **70184629851**
70184630481

is in conformity with the following standard:

- ***Supply of Machinery (Safety) Regulations 2008***
- ***Electromagnetic Compatibility Regulations 2016***
- ***Noise Emission in the Environment by Equipment for use Outdoors Regulations 2001***

and European standard:

- ***EN 12418 – Masonry and stone cutting-off machines – Safety***

Valid for machines with a serial number greater than: 4500000000

Authorised Representative:

SAINT-GOBAIN ABRASIVES
Unicorn House • Unit 1, Amison Close
Redhill Business Park • Stafford • England • ST16 1WB

This declaration of conformity loses its validity when the product is converted or modified without agreement.

Bascharage, 14.03.2023



François Chianese, executive officer and responsible for the technical file.
Bascharage, Luxembourg.

CGW

OPERATING INSTRUCTIONS

<u>1</u>	<u>BASIC SAFETY INSTRUCTIONS</u>	<u>6</u>
1.1	<i>Symbols</i>	6
1.2	<i>Machine plate</i>	7
1.3	<i>Safety instructions for particular operating phases</i>	7
<u>2</u>	<u>MACHINE DESCRIPTION</u>	<u>8</u>
2.1	<i>Short description</i>	8
2.2	<i>Purpose of use</i>	8
2.3	<i>Layout</i>	8
2.4	<i>Technical Data</i>	10
2.5	<i>Statement regarding the vibration emission</i>	11
2.6	<i>Statement regarding noise emission</i>	12
<u>3</u>	<u>ASSEMBLY AND COMMISSIONING</u>	<u>13</u>
3.1	<i>Tool assembly</i>	13
3.2	<i>Feet and conveyor cart assembly</i>	13
3.3	<i>Electrical connections</i>	13
3.4	<i>Starting the machine</i>	13
3.5	<i>Water cooling system</i>	14
<u>4</u>	<u>OPERATING THE MACHINE</u>	<u>15</u>
4.1	<i>Site of work</i>	15
4.2	<i>Cutting methods</i>	15
<u>5</u>	<u>TRANSPORT AND STORING</u>	<u>16</u>
5.1	<i>Securing for transport</i>	16
5.2	<i>Transport procedure</i>	17
5.3	<i>Long period of inactivity</i>	17
<u>6</u>	<u>MAINTENANCE AND SERVICING</u>	<u>18</u>
<u>7</u>	<u>FAULTS: CAUSES AND CURES</u>	<u>19</u>
7.1	<i>Fault-finding procedures</i>	19
7.2	<i>Trouble-shooting guide</i>	19
7.3	<i>Circuit diagram</i>	20
7.4	<i>Customer service</i>	22
7.5	<i>Spare parts</i>	23

1 BASIC SAFETY INSTRUCTIONS

The CGW is exclusively designed for the cutting of construction products mainly on construction sites.

Uses other than the manufacturer's instructions shall be considered as contravening the regulations. The manufacturer shall not be held responsible for any resulting damage. Any risk shall be borne entirely by the user. Observing the operating instructions and compliance with inspection and servicing requirements shall also be considered as included under use in accordance with the regulations.

1.1 Symbols

Important warnings and pieces of advice are indicated on the machine using symbols. The following symbols are used on the machine:



Read operator's instructions



Ear protection must be worn



Hand protection must be worn



Eye protection shall be worn

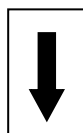







Rotation direction of the blade



Danger: risk of cut

1.2 Machine plate

Important data can be found on the following plate located on the machine:

 SAINT-GOBAIN 190, Bd. J.F. Kennedy L-4930 BASCHARAGE LUXEMBOURG	Code: Machine Code	Year: Year of production	 = Ø Maximum blade mm	  
	Mod: Machine Model	W= Weight kg	 = Ø Bore mm	
	EN: Safety standard	P= Power kW	 = Blade speed RPM	
	Type: Machine type	Serial N°: Serial number		

1.3 Safety instructions for particular operating phases

Before commencing work

- Before commencing work, make yourself familiar with the working environment at the place of use. The working environment includes: obstacles in the area of work and manoeuvre, the firmness of the floor, necessary protection at the site relating to public thoroughfares and the availability of help in the event of accidents.
- Check for correct mounting of the blade regularly.
- Immediately remove damaged or badly worn blades, as they endanger the operator whilst rotating.
- Only fit NORTON diamond blades to the machine! The use of other tools can damage the machine!
- Attention is drawn to the use of BS2092 safety goggles in conformity with specified Processes No.8 of the Protection of Eyes Regulation 1974, Regulation 2(2) Part 1.
- For security reasons, never leave the machine unattended, untied or unlocked.

While the engine is running

- Do not move the machine whilst the blade is running idle.
- Always cut with the blade guard in position.
- Apply cooling water continuously whilst cutting and in good time!

Petrol powered machines:

- Always use the fuel advised.
- In confined areas, exhaust gases should be evacuated and the job site properly aerated.
- Petrol and diesel machines, which by their nature emit toxic exhaust gases, must not be used in places prohibited by the Health at Work etc. Act 1974 or which are prohibited by Factory Inspectors or Safety Officers.
- Fuel is flammable. Before filling the tank, shut down the engine, extinguish all open flames and do not smoke. Take care that no petrol is spilled on any motor part. Always wipe up spilled fuel.

2 MACHINE DESCRIPTION

Any modification, which could lead to a change in the original characteristics of the machine, may be done only by Saint-Gobain Abrasives who shall confirm that the machine is still in conformity with the safety regulations.

2.1 Short description

The CGW Masonry saw is designed for durability and high performance for onsite wet and dry cutting operations of a wide range of masonry, refractory and natural stone products.

As with all other NORTON products, the operator will immediately appreciate the attention given to detail and quality of materials used in construction. The machine and its component parts are assembled to high standards assuring long life and minimum maintenance.

2.2 Purpose of use

The machine is designed for wet and dry cutting of a large range of building and refractory materials, or tiles. It is not designed for cutting wood or metals.

2.3 Layout



Frame and feet (1)

The frame is made of a jig-welded reinforced steel construction to ensure perfect rigidity. 4 removable legs fit into housings welded on frame sides and locked into place with wing screws.

Cutting head (2)

Spring loaded jig-welded steel console. The motor fixing points and the pivot are machined for perfect fit. A locking system allows straight-through cutting without any other accessory.

Blade guard (3)

Jig-welded steel construction with 350mm-diameter blade capacity, which offers maximum operator protection and increased visibility of the work piece.

Incorporated in the blade guard is an outer metal cover, which can be easily removed to allow easy access to shaft for inspection and blade replacement when motor is switched off, while fully protecting the blade when in operation.

Blade shaft (4)

The inner collar is pressed onto the motor shaft, and the outer flange is tightened with a hexagonal nut (thread opposite to blade direction!).

Conveyor cart (5)

Steel welded construction with non-slip top.

The machine patented guide system permits precise cuts to be made by virtue of four roller sheaves set at an inclination to compensate for wear.

The nylon-plastic sheaves and sealed-bearings permit easy operation. The variable angle guide-a-cut and the large surface area of the conveyor cart permits precise positioning of the material.

Water cooling system (6)

The coolant system comprises:

- A powerful, submersible electric water pump.
- Plastic suction pipe delivering the water from the water pan to the cutting head.
- A large capacity water pan supplied with drain plug.
- A water-tap, fitted to the blade guard, permitting controlled water flow.
- Two water nozzles located on the blade guard ensure adequate flow of water to both sides of the cutting blade.
- A water curtain, fixed to head axle restricts water spray and minimises water loss.
- The pump switch is located on the right side of the main switch.

Electrical Motor (7)

Leroy-Somer motor. The electric motor has an overload protection. Thermal overload tripping can occur for two reasons: tripping under light load if connection is incorrect, and tripping under heavy load if motor has been overloaded.

The ON-OFF switch also serves as emergency stop. The pump switch is located on the right side of the main switch. Low voltage trigger (NVR) built in the switch prevents the motor to restart for example after a power cut.

2.4 Technical Data

Electric motor	2,2 kW 230V with thermal overload protection 1,5kW 115V with thermal overload protection
Electric motor protection	IP54
Max. blade diameter	350 mm
Bore	25,4 mm
Rotation speed of the blade	2800 min ⁻¹
Flange diameter	90 mm
Cutting depth mm	110 mm (without reversing the material)
Sound pressure level	80 dB (A) (ISO EN 11201)
Sound energy level	92 dB (A) (ISO EN 3744)
Max. cutting length mm	500 mm
Table dimension (LxW)	440x340 mm
Machine dimensions without feet (LxWxH)	980x600x550 mm
Machine dimensions with feet (LxWxH)	980x600x1250 mm
Weights	
Machine cpl.	66 kg
Ready for use (with water)	100 kg

2.5 Statement regarding the vibration emission

Declared value of vibration emission following **EN 12096**.

Machine Model / code	Measured value of vibration emission at m/s ²	Uncertainty K m/s ²	Tool used Model / code
CGW 230V 70184629851 CGW 115V 70184630481	<2.5	0.5	Clipper ALFA

- The vibration value is lower and does not exceed 2.5 m / s.
- Values determined using the procedure described in the standard **EN 12418**.
- The measurements are made with new machines. Actual values may vary with site conditions, in terms of:
 - Materials worked
 - Wear Machine
 - Lack of maintenance
 - Inappropriate tool for application
 - Tool in poor condition
 - Unskilled operator
 - Etc...
- The exposure time to vibration is based on the performance of work (related to the adequacy Machine / Tool / worked material / operator)

When evaluating risks due to hand-arm vibration, you need to take into account effective usage at rated power of machine during a full day of work; quite often you will realise that effective utilisation time represents around 50% of overall duration of work. You have to consider, of course, breaks, water feeding, preparation of work, time to move the machine, disk mounting...

2.6 Statement regarding noise emission

Declared value of noise emission following **EN ISO 11201** and **NF EN ISO 3744**.

Machine Model / code	Sound Pressure level L_{Peq} EN ISO 11201	Uncertainty K (Sound Pressure level L_{Peq} EN ISO 11201)	Sound power level L_{Weq} NF EN ISO 3744	Uncertainty K (Sound power level L_{Weq} NF EN ISO 3744)
CGW 230V 70184629851	80 dB(A)	2.5 dB(A)	92 dB(A)	4 dB(A)
CGW 115V 70184630481				

- Values determined using the procedure described in the standard **EN 12418**.
- The measurements are made with new machines. Actual values may vary with site conditions, in terms of:
 - Wear Machine
 - Lack of maintenance
 - Inappropriate tool for application
 - Tool in poor condition
 - Unskilled operator
 - Etc...

Measured values relate to an operator in normal use, as described in the manual position

3 ASSEMBLY AND COMMISSIONING

The machine is delivered fully equipped (although without diamond blade). It is ready for operation assembly the diamond blade, the feet and the conveyor cart and after connection to the appropriate power supply.

3.1 Tool assembly

Only NORTON blades with a maximum diameter of 350 mm can be used with the CGW.

All tools used must be selected with regard to their maximum permitted cutting speed for the machine's maximum permitted rotation speed.

Before mounting a new blade into the machine, switch off the machine and isolate it from the main source of electricity.

To mount a new blade, follow these steps:

- Loosen on the outside cover of blade guard the three wing nuts and remove the outer guard.
- Loosen the hexagonal nut on the blade shaft (Caution: left threaded), which holds the removable outer flange.
- Remove the outer flange.
- Clean the flanges and blade shaft and inspect for wear.
- Mount the blade on arbor ensuring that direction of rotation is correct. Wrong direction of rotation blunts the blade quickly.
- Replace outer blade flange.
- Tighten hexagonal nut with spanner supplied for this purpose.
- Remount the removable blade guard and tighten the three wing nuts.

The blade bore must correspond exactly to the diameter of the blade shaft. Cracked or damaged bore is dangerous for the operator and for the machine.

3.2 Feet and conveyor cart assembly

Feet and conveyor cart are located in the water pan. Place the four feet in the four openings on each corner of the frame. Tighten the four wing screws.

Place the conveyor cart on the guiding rails with the material stop facing the operator.

3.3 Electrical connections

Check that,

- the voltage/phase supply corresponds to the information indicated on the motor plate.
- Available power supply must have ground connection in conformity with safety regulations.
- The connecting cables should have at least a 2.5mm²-section per phase.

3.4 Starting the machine

Open the cover on the switch and press the green button to start the machine. Either press on the red button or directly on the switch cover to stop the machine.

3.5 *Water cooling system*

Fill the water pan with clean water to approximately 2cm from top (ensure that bottom of pump is fully immersed in water). Use the pump switch on the side of the main switch to start the pump.

Open the water-tap on blade guard (note that handle on water-tap should be in line with water-flow).

Ensure that water is flowing freely in the circuit and is delivered adequately to both sides of the blade, as insufficient water supply may result in premature failure of the diamond blade.

The water pump must never run without water. Always make sure that there is enough water in the pan and refill if necessary.

In case of frost, empty the water cooling system from its water.

4 OPERATING THE MACHINE

4.1 Site of work

4.1.1 Siting the machine

- Remove from the site anything, which might hinder the working procedure!
- Make sure the site is sufficiently well lit!
- Observe manufacturer's conditions for connecting to power supplies!
- Place electric cables in such a way that damage by the device is excluded!
- Make sure you have a continual adequate view of the working area so you can intervene in the working process at any time!
- Keep other staff out of the area, so you can work securely.

4.1.2 Space required for operation and maintenance

Leave 2 m in front of the machine and 1,5 m around it for usage and maintenance of the CGW.

4.2 Cutting methods

To use the machine correctly, you must face it with one hand on the handle of the cutting head, and the other on the conveyor cart. Always keep your hands away from the moving blade. Open the switch cover and press the green button to start the machine. To stop either use the red button or press directly on the switch front cover.

4.2.1 Full depth or fixed cutting

In full depth or fixed cutting, the cutting head is locked in a fixed position and the material is pushed into it as shown.

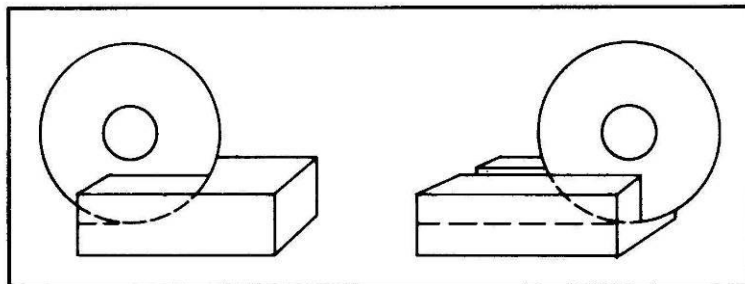

- Lower the cutting head to the desired cutting depth (in “through cutting”, lower cutting head until blade periphery reaches max. 3mm under the surface of the conveyor cart) by means of the handle on the blade guard
- Fix position by tightening the clamping device
- Put material on conveyor cart
- Push the conveyor cart slowly and without undue pressure towards the rotating blade and cut the material as shown on the picture.

NOTE: While recommended, it is not absolutely necessary to lock the cutting head into a given depth position when jam cutting. The desired cutting depth can be maintained by holding firmly the depth feed handle on the blade guard. If the full depth of cut requires excessive pressure (on very dense material e.g.) make 2 or 3 shallow cuts.

4.2.2 Multiple step cutting

Multiple step cutting consists of moving the conveyor cart with the material to be cut back and forward under the rotating blade,

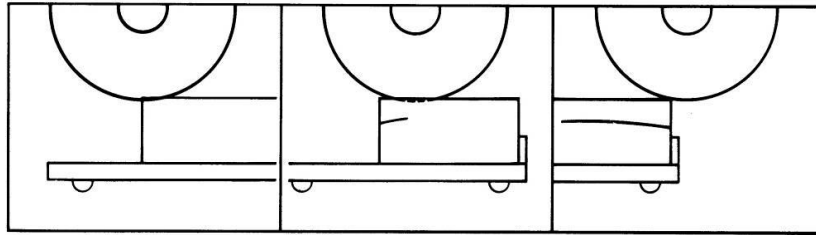

- Place the material to be cut on the conveyor cart firmly against the guide-a-cut and the backstop, keeping the hands well away from the blade.
- Move conveyor cart forward near the blade and pull down the cutting head until blade is lowered to a point where it will lightly contact the surface of the material.
- Then pass the material beneath with rapid full length strokes, taking a shallow cut (approximately 3 mm deep as shown on the picture) on the forward. On the backward stroke, lift the blade just clear over the cutting line.
- Complete each rapid stroke backward and forward by passing the material beyond the centre of the blade before starting the reverse movement of the conveyor cart.

NOTE: the harder the material, the more rapid should be the forward and backward strokes.

Step cutting lessens the area of the blade circumference in contact with the material, keeping the blade cool, running free and cutting at peak efficiency.

4.2.3 General advice for the cutting

- Material weight under 15 kg and having dimensions smaller than 500x500x110mm can be cut with the machine.
- Before commencing work make sure tools are firmly seated!
- Select the right tools as recommended by the manufacturer depending on the material to be worked, the working procedure (dry or wet cut) to be carried out and the required efficiency.
- Apply cooling water continuously whilst cutting and in good time! Make sure the water pan contains enough water.
- When dry cutting, ensure sufficient dust extraction and wear a dusk protection mask!
- When cutting work is finished, close the water-tap so you can remove the cut pieces from the conveyor cart without getting wet.
- In case the thermal protection trips, wait until the motor has cooled down before starting the machine again.

5 TRANSPORT AND STORING

5.1 *Securing for transport*

Before transporting the machine, always remove the blade and empty the water pan. Also remove the conveyor cart, as it can be dangerous while you move the machine.

5.2 *Transport procedure*

Two people are necessary to move the machine. The machine can be moved with or without its feet. Always remove feet while transporting the machine in a van and a truck. The machine does not have lifting hooks.

5.3 *Long period of inactivity*

If the machine is not going to be used for a long period, please take the following measures:

- Completely clean the machine
- Empty the water system
- Take the water pump out of the slurry and clean it thoroughly.

The storage site must be clean, dry and at a constant temperature.

6 MAINTENANCE AND SERVICING

To ensure a long-term quality from the cutting with the CGW, please follow the maintenance plan below:

		Begin of the day	During the changing of tool	End of the day or more often if required	Every week	After a fault	After a damage
Whole machine	Visual control (general aspect, watertightness)						
	Clean						
Flange and blade fixing devices	Clean						
Motor cooling fans	Clean						
Water pump	Clean						
Water pan	Clean						
Water hoses and nozzles	Clean						
Water pump filter	Clean						
Cart guiding bars	Clean						
Motor housing	Clean						
Reachable nuts and screws	Tighten up						

Maintenance of the machine

Always perform the maintenance of the machine with the machine isolated from the electrical supply.

Lubrication

The CGW uses life-lubricated bearings. Therefore, you don't need to lubricate the machine at all.

Cleaning of the machine

Your machine will last longer if you clean it thoroughly after each day of work, especially water pump, water pan (which can be removed for easy cleaning), motor and blade flange.

7 FAULTS: CAUSES AND CURES

7.1 Fault-finding procedures

Should any fault occur during the use of the machine, turn it off, and isolate it from the electrical supply. Any works dealing with the electrical system or supply of the machine can only be carried out by a qualified electrician.

7.2 Trouble-shooting guide

Trouble	Possible source	Resolution
Motor is not running	No electricity	Check the electrical supply (fuse for example)
	Connection cable section too small	Change connection cable
	Defective connection cable	Change connection cable
	Defective switch	CAUTION : can only be solved by qualified electrician
	Defective motor	Change motor or contact motor manufacturer
Motor stops during the cutting, but can be restarted after a short period (overload protection)	Cutting advance too quick	Cut slowly
	Blade is blunt or glazed	Sharpen the blade in calcareous stone
	Defective blade	Change blade
	Wrong blade specification for the application	Change blade
No water on the blade	Not enough water in the pan	Refill the water pan
	Water pump is switched off	Switch the water pump on
	Water tap is closed	Open tap on blade cover
	Water supply system is blocked up	Clean water supply system
	Water pump is not working	Prime the pump Reactivate switch CAUTION : if switch trips again, problem can only be solved by a qualified electrician

7.3 Circuit diagram

115V

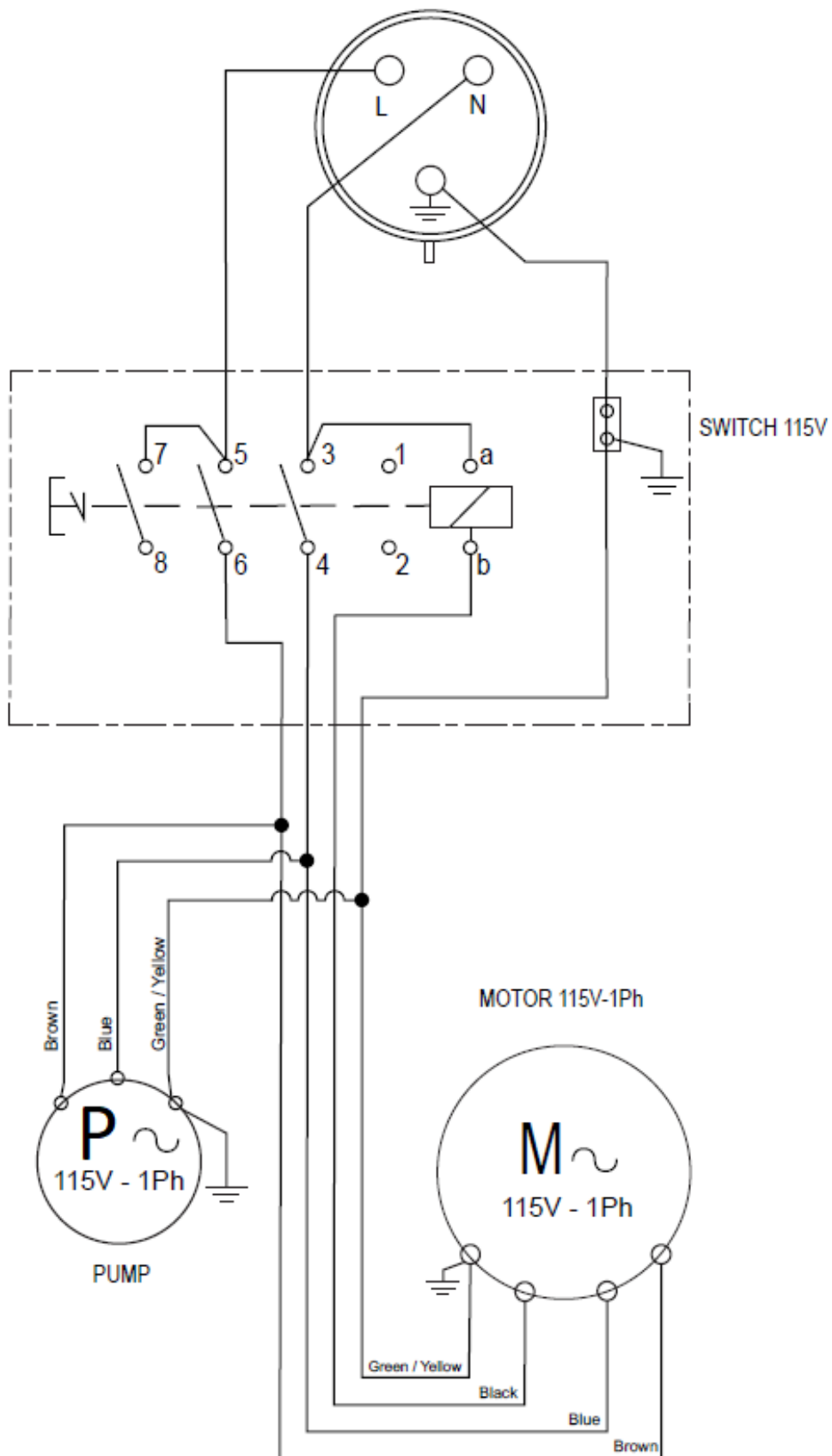

230V

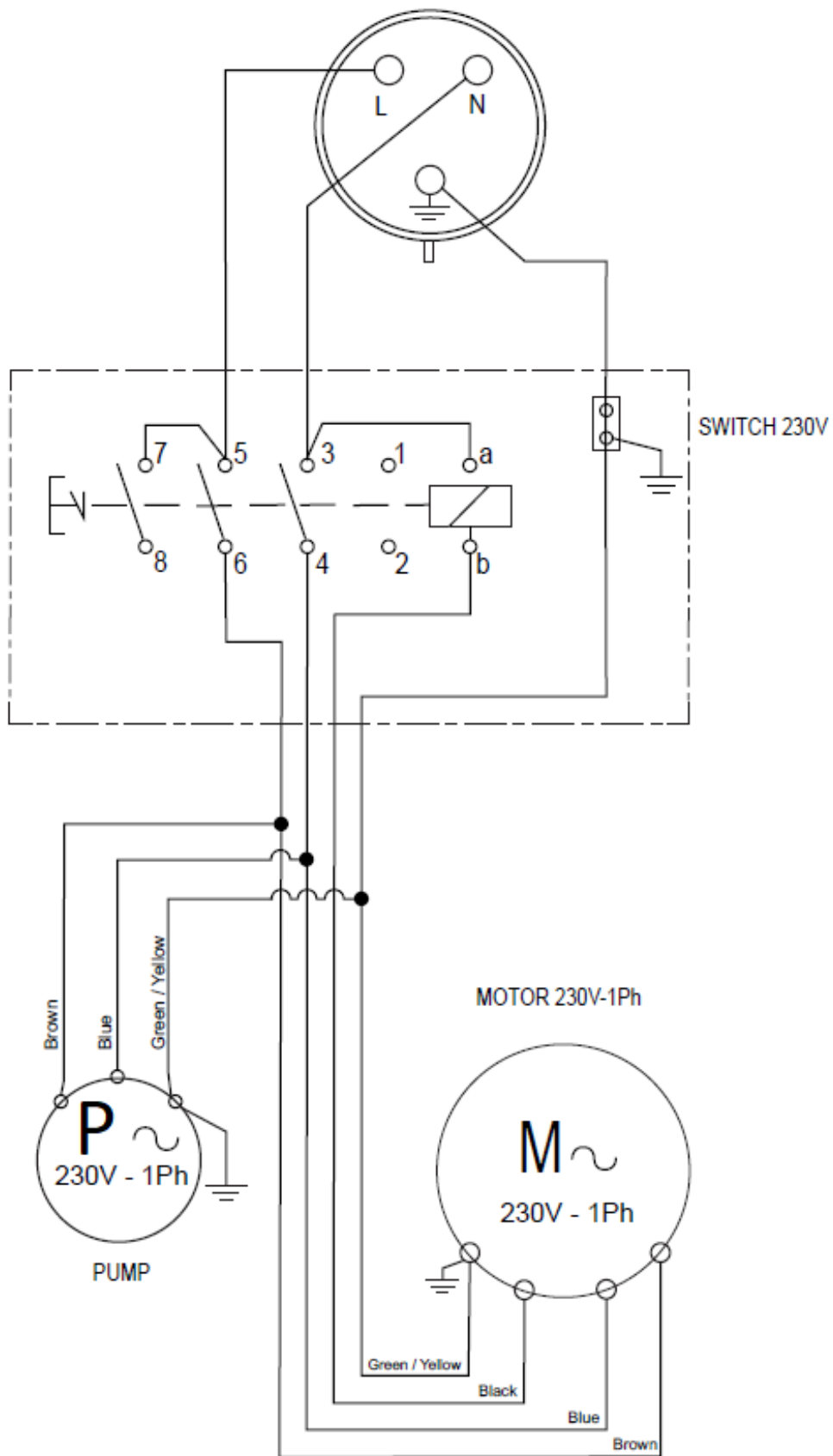

7.4 Customer service

When ordering spare parts, please mention:

- The serial number (7 digits).
- The code of the part.
- The exact denomination.
- The number of parts required.
- The delivery address.
- Please indicate clearly the means of transportation required such as "express" or "by air". Without specific instructions, we will forward the parts through the means which seem appropriate to us --- but which is not always the quickest way.

Clear instructions will avoid problems and faulty deliveries.

If not sure, please send us the defective part.

In the case of a warranty claim, the part must always be returned for evaluation.

Spare parts for the motor can be ordered with the manufacturer of the motor or with their dealer, which is often quicker and cheaper.

This machine has been manufactured by: Saint-Gobain Abrasives S.A.

190, Bd. J. F. Kennedy

L- 4930 BASCHARAGE

Grand-duché de Luxembourg.

Tel.: 00352-50 401-1

Fax: 00352- 50 16 33

<http://www.construction.norton.eu>

e-mail: sales.nlx@saint-gobain.com

7.5 Spare parts

In order to consult the spare parts lists, we invite you to visit the after-sales website of Norton Clipper by using the following address:

<https://spareparts.nortonabrasives.com>

For a quick access, you can also use the QR Code shown below using your mobile phone:



This electronic catalogue provides exploded views and spare parts lists for different machines designed by Norton Clipper so you can find references you need.

Guarantee can be claimed and technical support obtained from your local distributor where machines, spare parts and consumables can be ordered as well:

SAINT-GOBAIN ABRASIVES
INDUSTRIEWEG 21
9420 ERPE-MERE
BELGIUM
TEL: +32(0) 2 267 21 00

SAINT-GOBAIN CONSTRUCTION
PRODUCTS CZ A.S
DIVIZE ABRASIVES
SMRČKOVA 2485/4
180 00 PRAHA 8
CZECH REPUBLIC
TEL: +420 255 719 326
FAX: +420 255 719 321

SAINT-GOBAIN ABRASIVES A/S
DYBENDALSVÆNGET 2,
DK-2630 TAASTRUP
DENMARK
TEL: +45 4675 5244

PO BOX 643706
FORTUNE TOWER OFFICE 2106
JLT BLOCK C
(NEXT TO METRO STATION)
JUMEIRA LAKE TOWER, DUBAI
UNITED ARAB EMIRATES
TEL: +971 4 431 5154
FAX: +971 4 431 5434

SAINT-GOBAIN ABRASIFS
RUE DE L'AMBASSADEUR - B.P.8
78 702 CONFLANS CEDEX
FRANCE
TEL: +33 (0)1 34 90 40 00
FAX: +33 (0)1 39 19 89 56

SAINT-GOBAIN ABRASIVES GMBH
BIRKENSTRASSE 45-49
D-50389 WESSELING
GERMANY
TEL: +49 (0) 2236 703-0
FAX: +49 (0) 2236 703-730

SAINT-GOBAIN ABRASIVES KFT.
1225 BUDAPEST
BÁNYALÉG U. 60/B.
HUNGARY
TEL: +36 1 371 22 50
FAX: +36 1 371 22 55

SAINT-GOBAIN ABRASIVI S.P.A
VIA PER CESANO BOSCONI 4
I-20094 CORSICO MILANO
ITALY
TEL: +39 02 44 851
FAX: +39 02 44 78 266

SAINT-GOBAIN ABRASIVES S.A.
190 RUE J.F. KENNEDY
L-4930 BASCHARAGE
GRAND DUCHE DE LUXEMBOURG
TEL: +352 50 401 1
FAX: +331 83 717 792
NO. VERT (FRANCE): 0800 906 903

SAINT-GOBAIN ABRASIFS, S.A.
2 ALLÉE DES FIGUIERS
AIN SEBAÄ - CASABLANCA
MOROCCO
TEL: +212 5 22 66 57 31
FAX: +212 5 22 35 09 65

SAINT-GOBAIN ABRASIVES BV
GROENLOSEWEG 28
7151 HW EIBERGEN
P.O. BOX 10
7150 AA EIBERGEN
THE NETHERLANDS
TEL: +31 545 466466
FAX: +31 545 474605

SAINT-GOBAIN ABRASIVES AS
KARIHAUGVEIEN, 89
0186 OSLO
NORWAY
TEL: +47 63 87 06 00
FAX: +47 63 87 06 01

SAINT-GOBAIN HPM POLSKA SP. Z O.O.
UL. NORTON 1, 62-600 KOŁO
62-600 KOŁO
POLAND
TEL: +48 63 26 17 100
FAX: +48 63 27 20 401

SAINT-GOBAIN ABRASIVOS, L. DA
ZONA INDUSTRIAL DA MAIA
I-SECTOR VIII, NO. 122
APARTADO 6050
4476 - 908 MAIA
PORTUGAL
TEL: +351 229 437 940
FAX: +351 229 437 949

SAINT-GOBAIN GLASS
BUSINESS UNIT ABRASIVI
PUNCT DE LUCRU : LOC.VETIS, JUD.
SATU MARE 447355
STR. CAREIULUI 11
PARC INDUSTRIAL RENOVATIO
ROMANIA
TEL: +40 261 839 709
FAX: +40 261 839 710

SG HPM RUS
58, F. ENGELS STR.
STROENIE 2
105082 MOSCOW
RUSSIA
TEL: +74 955 408 355
FAX: +74 959 373 224

SAINT-GOBAIN
ABRASIVES (PTY) LTD
2 MONTEER ROAD
ISANDO 1600
P.O. BOX 67
SOUTH AFRICA
TEL: +27 11 961 2000
FAX: +27 11 961 2184/5

SAINT-GOBAIN ABRASIVOS, S.A.
CTRA. DE GUIPÚZCOA, KM. 7,5
E-31195 BERRIOPLANO (NAVARRA)
SPAIN
TEL: +34 948 306 000
FAX: +34 948 306 042

SAINT GOBAIN ABRASIVES AB
GÅRDSFOGDEVÄGEN 18A
168 66 BROMMA • SVERIGE
SWEDEN
TEL: +46 8 580 881 00
FAX: +46 8 580 881 30

SAINT-GOBAIN INOVATIF MALZEMELER
VE ASINDIRICI SAN. TIC. AS.
ALTAYÇEŞME MAH. ÇAMLI SOK. NO:21
ESAS OFIS PARK KAT:9 34843
MALTEPE, İSTANBUL • TURKEY
TEL: 0090-216-217 12 50
FAX: 0090-216-442 40 74

SAINT-GOBAIN ABRASIVES LTD.
UNICORN HOUSE UNIT 1, AMISON CLOSE
REDHILL BUSINESS PARK
STAFFORD ST161WB
UNITED KINGDOM
TEL: +44 1785 279 553
FAX: +44 1785 213 487



Saint-Gobain Abrasifs
190 Rue J.F. Kennedy
L-4930 Bascharage
Grand Duche de Luxembourg
Tel: +352 50 401 1
Fax: +331 83 717 792
no. vert (France) 0800 906 903

www.nortonabrasives.com/fr-fr