

Jumbo 1000 P13

OPERATING INSTRUCTIONS

Translation of the original instructions





The undersigned manufacturer:

SAINT - GOBAIN ABRASIVES S.A.
190, BD J.F. KENNEDY
L- 4930 BASCHARAGE

Declares that this product:

Masonry Saws: **JUMBO 1000 P13**

Code: **70184629335**

is in conformity with the following Directives:

- **"MACHINES" 2006/42/CE**
- **"ELECTROMAGNETIC COMPATIBILITY" 2014/30/UE**
- **"NOISE" 2000/14/CE**

And European standard:

- **EN 12418 – Masonry and stone cutting-off machines – Safety**

Valid for machines as of serial number: 130400000

Storage site for the technical documents:

Saint-Gobain Abrasives 190, Bd. J. F. Kennedy 4930 BASCHARAGE, LUXEMBOURG

This declaration of conformity loses its validity when the product is converted or modified without agreement.

Bascharage, Luxembourg, 01.10.2020.

A handwritten signature in blue ink, appearing to read "F. Chianese".

François Chianese, executive officer.



Declaration of conformity

The undersigned manufacturer:

SAINT - GOBAIN ABRASIVES S.A.
190, BD J.F. KENNEDY
L- 4930 BASCHARAGE

Declares that this product:

Masonry Saws: **JUMBO 1000 P13**

Code: **70184629335**

is in conformity with the following standard:

- ***Supply of Machinery (Safety) Regulations 2008***
- ***Electromagnetic Compatibility Regulations 2016***
- ***Noise Emission in the Environment by Equipment for use Outdoors Regulations 2001***

and European standard:

- ***EN 12418 – Masonry and stone cutting-off machines – Safety***

Valid for machines with a serial number greater than: 130400000

Authorised Representative:

SAINT-GOBAIN ABRASIVES

Unicorn House • Unit 1, Amison Close

Redhill Business Park • Stafford • England • ST16 1WB

This declaration of conformity loses its validity when the product is converted or modified without agreement.

Bascharage, Luxembourg, 01.10.2020.

A handwritten signature in blue ink, appearing to read 'fchianese', is written over a light blue scribble.

François Chianese, executive officer.

JUMBO 1000 P13

OPERATING INSTRUCTIONS

<u>1</u>	<u>BASIC SAFETY INSTRUCTIONS</u>	<u>7</u>
1.1	<i>Symbols</i>	7
1.2	<i>Machine plate</i>	8
1.3	<i>Safety instructions for particular operating phases</i>	8
<u>2</u>	<u>MACHINE DESCRIPTION</u>	<u>9</u>
2.1	<i>Short description</i>	9
2.2	<i>Purpose of use</i>	9
2.3	<i>Layout</i>	9
2.4	<i>Technical Data</i>	11
2.5	<i>Statement regarding the vibration emission</i>	12
2.6	<i>Statement regarding noise emission</i>	13
<u>3</u>	<u>ASSEMBLY AND COMMISSIONING</u>	<u>14</u>
3.1	<i>Tool assembly</i>	14
3.2	<i>Starting the machine</i>	15
3.3	<i>Water cooling system</i>	16
<u>4</u>	<u>TRANSPORT AND STORING</u>	<u>17</u>
4.1	<i>Securing for transport</i>	17
4.2	<i>Transport procedure</i>	17
4.3	<i>Long period of inactivity</i>	17
<u>5</u>	<u>OPERATING THE MACHINE</u>	<u>18</u>
5.1	<i>Site of work</i>	18
5.2	<i>Cutting methods</i>	18
<u>6</u>	<u>MAINTENANCE AND SERVICING</u>	<u>20</u>
6.1	<i>Maintenance of the machine</i>	20
6.2	<i>Maintenance of the engine</i>	21
<u>7</u>	<u>FAULTS: CAUSES AND CURES</u>	<u>24</u>
7.1	<i>Fault-finding procedures</i>	24
7.2	<i>Trouble-shooting guide</i>	24
7.3	<i>Customer service</i>	25

1 BASIC SAFETY INSTRUCTIONS

The Jumbo 1000 P13 is exclusively designed for the cutting of construction products mainly on construction sites.

Uses other than the manufacturer's instructions shall be considered as contravening the regulations. The manufacturer shall not be held responsible for any resulting damage. Any risk shall be borne entirely by the user. Observing the operating instructions and compliance with inspection and servicing requirements shall also be considered as included under use in accordance with the regulations.

1.1 Symbols

Important warnings and pieces of advice are indicated on the machine using symbols. The following symbols are used on the machine:



Read operator's instructions



Ear protection must be worn



Hand protection must be worn



Eye protection shall be worn

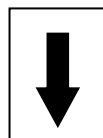

Rotation direction of the blade



Danger: risk of cutting

1.2 Machine plate

Important data can be found on the following plate located on the machine:

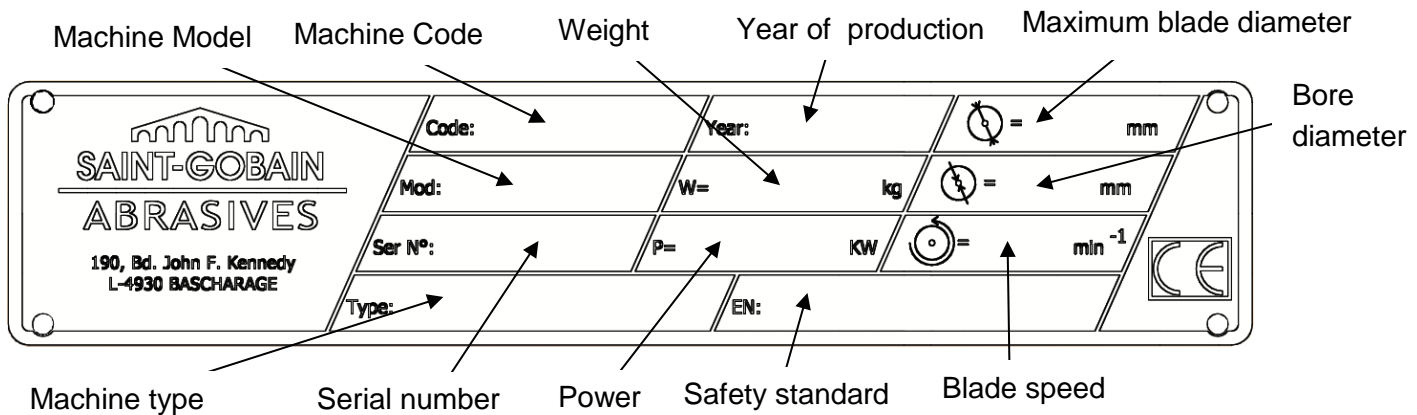

1.3 Safety instructions for particular operating phases

Before commencing work

- Before commencing work, make yourself familiar with the working environment at the place of use. The working environment includes: obstacles in the area of work and manoeuvre, the firmness of the floor, necessary protection at the site relating to public thoroughfares and the availability of help in the event of accidents.
- Site the machine on an even, firm and stable base!
- During work, apply the brakes located on two of the four wheels.
- Check for correct mounting of the blade regularly.
- Immediately remove damaged or badly worn blades, as they endanger the operator whilst rotating.
- The material to be cut must be held securely in place on the cutting table allowing no movement during cutting operation.
- Always cut with the blade guard in position.
- Only fit NORTON diamond blades to the machine! The use of other tools can damage the machine!
- Read the blades' specifications carefully to choose the correct tool for your application.
- Attention is drawn to the use of BS2092 safety goggles in conformity with specified Processes No.8 of the Protection of Eyes Regulation 1974, Regulation 2(2) Part 1. Also use other safety equipment as mentioned in point 1.1.

2 MACHINE DESCRIPTION

Any modification, which could lead to a change in the original characteristics of the machine, may be done only by Saint-Gobain Abrasives who shall confirm that the machine is still in conformity with the safety regulations.

2.1 Short description

The JUMBO 1000 P13 block saw is designed for durability and high performance for onsite wet cutting operations of a wide range of masonry, refractory and natural stone products.

As with all other NORTON products, the operator will immediately appreciate the attention given to detail and quality of materials used in construction. The machine and its component parts are assembled to high standards assuring long life and minimum maintenance.

2.2 Purpose of use

The machine is designed for cutting a large range of building and refractory materials. **It is not designed for cutting wood or metals.**

2.3 Layout



Frame (1)

Jig-welded, reinforced and all-steel construction ensures perfect rigidity. The frame includes a large capacity water tray with drain plug. Frame has built-in lift brackets (8) for easy transportation and is mounted on 4 wheels, 2 of which have a locking device to secure the machine during cutting.

Cutting head (2)

Jig-welded steel console equipped with pivot bar fixed to frame upright and housed in heavy-duty bearings. Console supports the electric motor, the belt drive with its guard and the blade shaft assembly. Bearings are machined for perfect fit and alignment. Precision-machined blade shaft held in ball bearings and is driven by three heavy-duty V-section drive belts. The blade shaft assembly is completely enclosed in a cutting head console, accessible for inspection by way of a removable plate. The removable blade flange is tightened by means of a hexagonal nut. The spring-loaded cutting head ensures smooth lowering of the cutting head. A depth-locking device fixed to cutting head and frame enables the operator to set the cutting head to desired or to maximum cutting depth. The movement of the head is ensured by a handwheel (6).

Water cooling system (3)

The coolant system comprises:

- A powerful mechanical water pump
- Plastic suction pipe delivering the water from the water pan to the cutting head
- A large capacity water pan (pan is galvanised) supplied with drain plug
- A water-tap, fitted to the blade guard, permitting controlled water flow
- Two water nozzles located on the blade guard ensure adequate flow of water to both sides of the cutting blade
- Water curtains, fixed to frame and blade guard to restrict water spray and to minimise water loss

Attention: The water pump must never run without water.

Blade guard (4)

Jig-welded steel construction with 1000mm-diameter blade capacity, offers maximum operator protection and increased visibility of the work piece. Incorporated in the blade guard is an outer detachable metal cover, which permits easy access to shaft for inspection and blade replacement when motor is switched off, while fully protecting the blade when in operation.

Cutting table (5)

Large, heavy-duty and galvanised table fitted with water flow-control vents. The table is equipped with a backstop and with a guide-a-cut device.

Slide front protection (7)

The slide front retrieves the projection water in front of the machine, and protects the blade zone that exceed of the table when we cut.

2.4 Technical Data

Motor	Honda GX390 9,7kW (13HP)
Fuel	Automotive unleaded gasoline
Oil	Honda 4-Stroke, or equivalent high detergent, premium quality motor oil certified to meet or exceed U.S. automobile manufacturer's requirement for service classification SG, SF. (SG, SF designated on the oil container). SAE 10W-30 recommended
Max. blade diameter	1000mm
Bore	60mm
Cutting length mm	720mm
Cutting depth mm	420mm
Table dimension	720x800mm
Flange diameter	160mm
Blade shaft speed	928 min ⁻¹
Machine dimensions	2310x1080x1700mm
Weight	370 kg
Max. operating weight	430 kg
Sound pressure level	88 dB (A) (according to ISO EN 11201)
Sound energy level	105 dB (A) (according to ISO EN 3744)

2.5 Statement regarding the vibration emission

Declared value of vibration emission following **EN 12096**.

Machine Model / code	Measured value of vibration emission at m/s ²	Uncertainty K m/s ²	Tool used Model / code
JUMBO 1000 P13 70184629335	<2.5	0.5	Norton Pro BS - 12

- The vibration value is lower and does not exceed 2.5 m/s².
- Values determined using the procedure described in the standard **EN 12418**.
- The measurements are made with new machines. Actual values may vary with site conditions, in terms of:
 - Materials worked
 - Wear Machine
 - Lack of maintenance
 - Inappropriate tool for application
 - Tool in poor condition
 - Unskilled operator
 - Etc...
- The exposure time to vibration is based on the performance of work (related to the adequacy Machine / Tool / worked material / operator)
- When evaluating risks due to hand-arm vibration, you need to take into account effective usage at rated power of machine during a full day of work; quite often you will realise that effective utilisation time represents around 50% of overall duration of work. You have to consider, of course, breaks, water feeding, preparation of work, time to move the machine, disk mounting...

2.6 Statement regarding noise emission

Declared value of noise emission following **EN ISO 11201** and **NF EN ISO 3744**.

Machine Model / code	Sound Pressure level L_{Peq} EN ISO 11201	Uncertainty K (Sound Pressure level L_{Peq} EN ISO 11201)	Sound power level L_{Weq} NF EN ISO 3744	Uncertainty K (Sound power level L_{Weq} NF EN ISO 3744)
JUMBO 1000 P13 70184629335	88 dB(A)	2.5 dB(A)	105 dB(A)	4 dB(A)

- Values determined using the procedure described in the standard **EN 12418**.
- The measurements are made with new machines. Actual values may vary with site conditions, in terms of:
 - Wear Machine
 - Lack of maintenance
 - Inappropriate tool for application
 - Tool in poor condition
 - Unskilled operator
 - Etc...
- Measured values relate to an operator in normal use, as described in the manual position.

3 ASSEMBLY AND COMMISSIONING

The machine is delivered fully equipped and assembled and is ready for operation after connection to the appropriate power supply.

3.1 *Tool assembly*

Use only NORTON blades with a maximum diameter of 1000 mm on the Jumbo 1000 P13.

All tools used must be selected with regard to their maximum permitted cutting speed for the machine's maximum permitted rotation speed.

Switch off the engine before mounting a new blade into the machine.

To mount a new blade, follow these steps:

- Disconnect water hoses from the blade guard.
- Open the blade guard.
- Loosen the hexagonal nut on the blade shaft while holding the shaft (with the two 36mm spanners supplied with the machine), which holds the removable outer flange.
- Remove the outer flange.
- Clean the flanges and blade shaft and inspect for wear.
- Mount the blade on arbour ensuring that direction of rotation is correct. Wrong direction of rotation blunts the blade quickly.
- Replace outer blade flange.
- Tighten hexagonal nut while holding the shaft with spanners supplied for this purpose.
- Shut retractable blade guard cover and reconnect water hoses.

ATTENTION: The blade bore must correspond exactly to the diameter of the blade shaft. Cracked or damaged bore is dangerous for the operator and for the machine.

3.2 Starting the machine

Make sure that the blade does not touch the cutting table when you start the engine.

<p>Turn the fuel valve to the ON position.</p>	<p>Move the choke lever to the CLOSED position. NOTE: do not use the choke if the engine is warm or the air temperature is high.</p>
<p>Move the throttle control lever slightly to the left.</p>	<p>Put the engine switch on ON, and make sure the emergency switch on the board of the machine is in the correct position.</p>
<p>Pull the starter grip lightly until you feel resistance, then pull briskly. CAUTION: Do not allow the starter grip to snap back against the engine. Return it gently to prevent damage to the starter.</p>	<p>As the engine warms up, gradually move the choke lever to the OPEN position. Position the throttle control lever for the maximum engine speed.</p>

To stop the engine, move the throttle control lever fully to the right, then turn the engine switch to the OFF position. Turn the fuel valve to the OFF position.

3.3 Water cooling system

- Fill the water pan with clean water to approximately 2,5cm from top (ensure that bottom of pump is fully immersed in water).
- The water flow is adjusted with a throttle located in the elbow.
- Ensure that water is flowing freely in the circuit and is delivered adequately to both sides of the blade.
- If the water supply is insufficient, this may result in premature failure of the diamond blade. That is why we must avoid pipes and nozzles are clogged.
- Open the slide front protection. The slide front protect the blade exceeding of the table when we cut.

- Do not run the water pump without water. Always make sure that there is enough water in the pan and refill if necessary.
- In case of frost, empty the water cooling system.

4 TRANSPORT AND STORING

Take the following measures in order to transport the JUMBO 1000 P13 securely.

4.1 *Securing for transport*

Before transporting or lifting the machine, always remove the blade and empty the water pan. Secure the head with the locking hook and handle.

4.2 *Transport procedure*

The machine can be moved on a flat surface using its wheels.

The machine can be moved with a forklift, use the specific support that there is under the frame for put the forks

Only use the lift brackets to lift the machine, as other parts of the machine are not designed for this purpose.

4.3 *Long period of inactivity*

If the machine is not going to be used for a long period, please take the following measures:

- Completely clean the machine
- Loosen the drive belts
- Empty the water system
- Take the water pump out of the slurry and clean it thoroughly.

The storage site must be clean, dry and at a constant temperature.

5 OPERATING THE MACHINE

5.1 Site of work

5.1.1 Siting the machine

- Remove from the site anything, which might hinder the working procedure!
- Make sure the site is sufficiently well lit!
- Make sure you have a continual adequate view of the working area so you can intervene in the working process at any time!
- Keep other staff out of the area, so you can work securely.

5.1.2 Space required for operation and maintenance

Leave 2 m in front of the machine and 1, 5 m around it for usage and maintenance of the Jumbo 1000 P13

5.2 Cutting methods

To use the machine correctly, you must be on the side of the machine with one hand on the handwheel, and the other ready to stop the machine in case of emergency. Always keep your hands away from the moving blade.

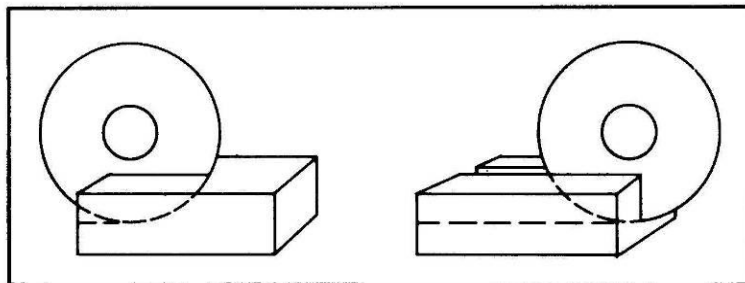

- Lower the cutting head to the desired cutting depth (in “through cutting”, lower cutting head until blade periphery reaches max. 3-5mm under the surface of the cutting table) by means of the handle on the blade guard and the scale over the head.
- Fix position by tightening the clamping device.
- Put material on cutting table.
- Start the engine (see point 3.2)
- Turn the handwheel slowly and without undue pressure towards the rotating blade and cut the material.
- Open the slide front protection. The slide front protect the blade exceeding of the table when we cut.
- Start the machine.

- When your cut is finished, turn the handwheel so that the blade is completely out of the material before stopping the machine.

REMARK: If the full depth of cut requires excessive pressure (on very dense material e.g.) make 2 or 3 shallow cuts.

5.2.1 General advice for the cutting

- Make sure you have filled the water and the fuel tank. No petrol is supplied with the machine.
- The engine is shipped with oil. Check oil level before starting. Top up if required.
- Material weighing up to 100 kg and having dimensions smaller than 720x800x370mm can be cut with the Jumbo 1000 P13.
- Before commencing work make sure the diamond blade is firmly seated!
- Select the right diamond blade as recommended by the manufacturer depending on the material to be worked, the working procedure (wet cut) to be carried out and the required efficiency.
- Open the slide front protection. The slide front protect the blade exceeding of the table when we cut.
- Make your sure that the water is flowing correctly. If the water supply is insufficient, this may result in premature failure of the diamond blade. That is why we must avoid pipes and nozzles are clogged.
- When cutting work is finished, stop the machine so you can remove the cut pieces from the cutting table without getting wet.

6 MAINTENANCE AND SERVICING

6.1 Maintenance of the machine

To ensure a long-term quality from the cutting with the Jumbo 1000 P13, please follow the maintenance plan below:

		Begin of the day	During the changing of the tool	End of the day	Every week	After a fault	After a damage
Whole machine	Visual control (general aspect, water tightness)						
	Clean						
Flange and blade fixing devices	Clean						
Belts tension	Check tension and adjust						
Water pan	Clean						
Water pump	Clean						
Water hoses and nozzles	Clean						
Water pump filter	Clean						
Head guiding bars	Clean						
Motor housing	Clean						
Reachable nuts and screws	Tighten up						

Maintenance of the motor

Always perform the maintenance with the motor switched off.

Adjustment and replacement of the belts

To adjust the belts, firstly remove the belt guard by unscrewing the 6 nuts. Loosen the 4 motor bolts and shift the motor by using the two screws on the side.

To replace the belts, move the motor completely forward. Adjust the belts and retighten them by shifting the motor to the left.

Always use a matched set of belts. Do not replace single belts.

Lubrication

The Jumbo 1000 P13 uses life-lubricated bearings. Therefore, you don't need to lubricate the machine at all.

Cleaning of the machine

Your machine will last longer if you clean it thoroughly after each day of work, especially water pump, water pan, motor, blade flange and cutting head rails.

6.2 Maintenance of the engine

		Each use	First month or 20 hours	Every 3 months or 50 hours	Every 6 months or 100 hours
<p>Regular service period Perform at every indicated month or operating hour interval, whichever comes first</p> <p style="text-align: right;">→</p>					
Engine oil	Check level				
	Change				
Air cleaner filter	Check				
	Clean				
Fuel strainer cup	Clean				
Spark plug	Check-Clean				
Fuel line	Check (Replace if necessary)	Every 2 years			

Engine oil

To change the oil,

- Remove the oil filler cap/dipstick and drain bolt.
- Allow the oil to drain completely.
- **Please dispose of used motor oil in a manner that is compatible with the environment. We suggest you to take used oil in a sealed container to your local recycling centre or service station for reclamation. Do not throw it in the trash, pour it on the ground or down in a drain.**
- Reinstall the drain bolt, and tighten it to 18 N.m.
- Fill the crankcase with the engine oil to the outer edge of the oil filler neck.
- Reinstall the filler cap/dipstick.

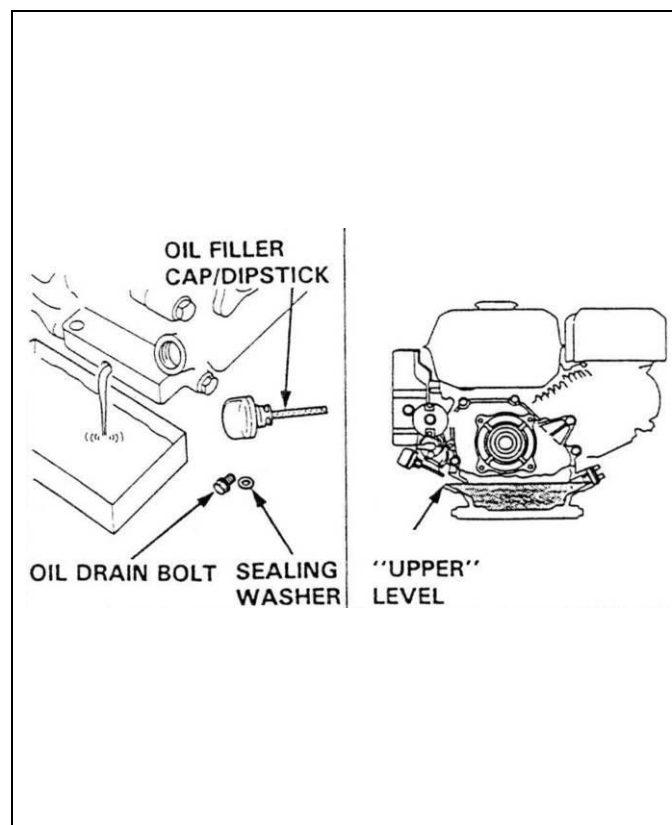

Air cleaner

The JUMBO 1000 P13 has a dual type filter.

To service the air cleaner filter, follow these instructions:

- Remove the nut, air cleaner cover and wing nut.
- Remove the pre air cleaner elements and separate them.
- Carefully check both elements for holes or tears and replace if damaged.

Paper element:

- Tap element lightly several times on a hard surface to remove excess dirt
- Blow compressed air lightly through the filter from the inside out.
- Never brush the dirt off; brushing will force dirt into the fibres.

Foam element:

- Clean in warm soapy water, rinse and allow to dry thoroughly.
- Dip the element in clean engine oil and squeeze out all the excess. The engine will smoke during initial start-up if too much oil is left in the foam.
- Shine a light through the elements, and inspect them carefully.

Reinstall the elements if they are free of holes and tears.

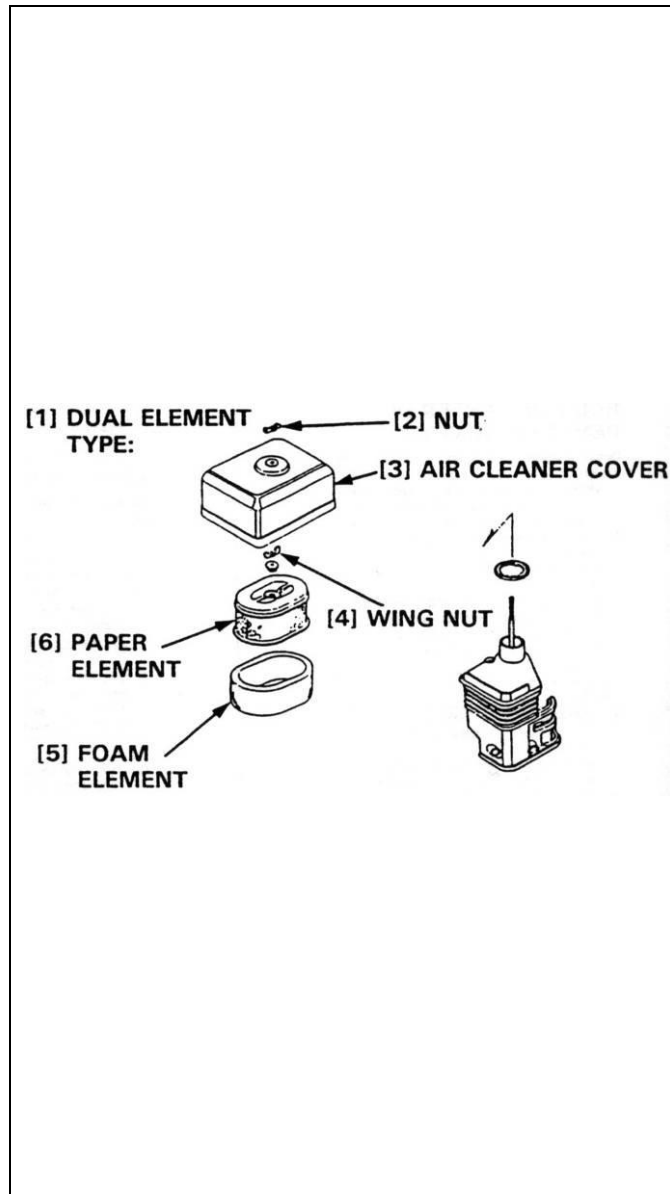

Fuel strainer cup

To service fuel strainer cup, follow these instructions:

- Turn off the fuel valve and remove the strainer cup.
- Clean the strainer cup with solvent.
- Install the O-ring and strainer cup.
- Tighten the strainer cup to 4N.m.

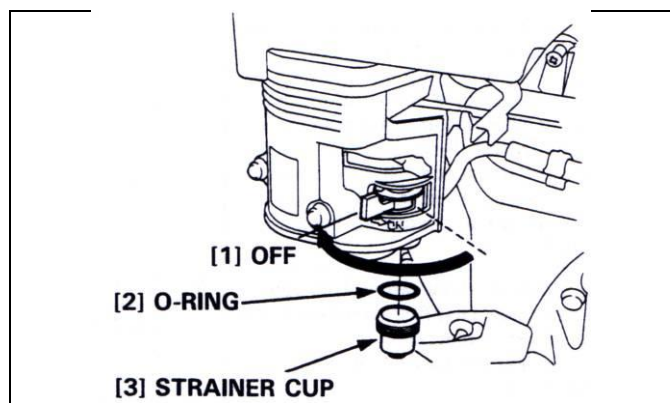

Spark plug

To service the spark plug, follow these instructions:

- Visually inspect the spark plug. Discard the plug if the insulator is cracked or chipped.
- Remove carbon or other deposits with a stiff wire brush.
- Measure the plug gap with a wire-type feeler gauge. If necessary, adjust the gap by bending the side electrode.
- Make sure the sealing washer is in good condition; replace the plug if necessary.
- Install the plug finger tight to seat the washer, then tighten with a plug wrench (an additional $\frac{1}{2}$ turn if a new plug) to compress the sealing washer. If you are reusing a plug, tighten $\frac{1}{8}$ - $\frac{1}{4}$ turn after the plug seats.

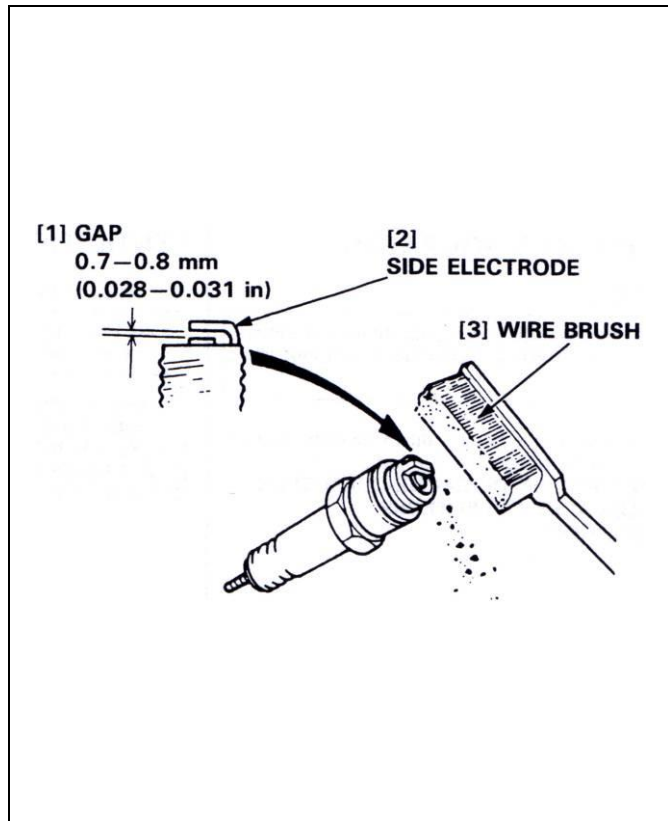

Fuel line

To service the fuel line, follow these instructions:

- Drain the fuel into a suitable container, and remove the fuel tank.
- Disconnect the fuel line, and unscrew the fuel filter from the tank.
- Clean the filter with solvent, and check, that the filter screen is undamaged.
- Place the O-ring on the filter and reinstall. Tighten the filter to 2N.m. After reassembly, check for fuel leaks.

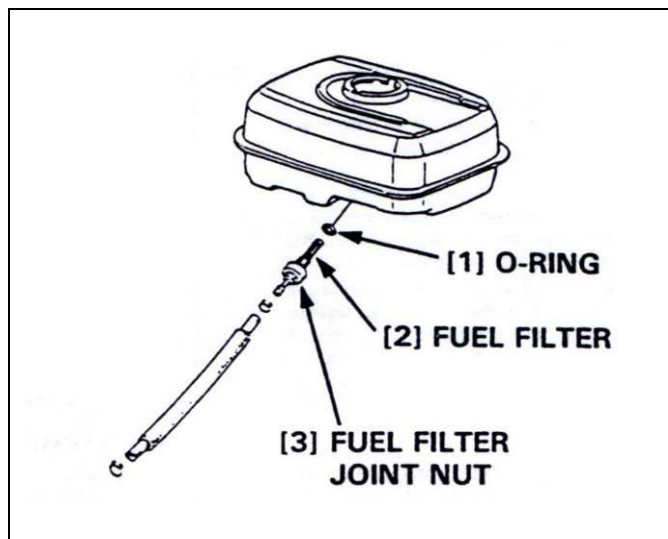

Further maintenance

For further maintenance, please contact the nearest engine maintenance centre.

7 FAULTS: CAUSES AND CURES

7.1 *Fault-finding procedures*

Should any fault occur during the use of the machine, turn it off.

7.2 *Trouble-shooting guide*

Trouble	Possible source	Resolution
Hard starting	Not enough fuel	Fill fuel tank
	Fuel filter clogged	Clean fuel filter
	Spark plug faulty	Inspect spark plug
	Stronger fault	Contact nearest engine maintenance centre
Blade is not turning	Belts not tightened or defective	Check the belts tension and change them if needed
Engine lacks power	Air filter restricted	Clean or replace air filter
	Stronger fault	Contact nearest engine maintenance centre
	Cutting advance too quick	Cut slowly
	Blade is blunt or glazed	Sharpen the blade in calcareous stone
	Defective blade	Change blade
	Wrong blade corresponding to the application	Change blade
No water on the blade	Not enough water in the pan	Refill the water pan
	Water supply system is blocked up	Clean water supply system
	Water pump is not working	<ul style="list-style-type: none"> • Check if pump pulley is driven by the belts Change the pump

7.3 Customer service

When ordering spare parts, please mention:

- The serial number (9 digits).
- The code of the part.
- The exact denomination.
- The number of parts required.
- The delivery address.
- Please indicate clearly the means of transportation required such as "express" or "by air". Without specific instructions, we will forward the parts through the means which seem appropriate to us --- but which is not always the quickest way.

Clear instructions will avoid problems and faulty deliveries.

If not sure, please send us the defective part.

In the case of a warranty claim, the part must always be returned for evaluation.

Spare parts for the motor can be ordered with the manufacturer of the motor or with their dealer, which is often quicker and cheaper.

This machine has been manufactured by Saint-Gobain Abrasives S.A.

190, Bd. J. F. Kennedy

L- 4930 BASCHARAGE

Grand-duché de Luxembourg.

Tel. : 00352-50401-1

Fax : 00352- 50 16 33

<http://www.construction.norton.eu>

e-mail: sales.nlx@saint-gobain.com

In order to consult the spare parts lists, we invite you to visit the after-sales website of Norton Clipper by using the following address:

<https://spareparts.nortonabrasives.com>

For a quick access, you can also use the QR Code shown below using your mobile phone:



Guarantee can be claimed and technical support obtained from your local distributor where machines, spare parts and consumables can be ordered as well:

SAINT-GOBAIN ABRASIVES
INDUSTRIEWEG 21
9420 ERPE-MERE
BELGIUM
TEL: +32(0) 2 267 21 00

SAINT-GOBAIN ABRASIVES, S.R.O.
POČERNICKÁ 272/96, MALEŠICE
108 00 PRAHA 10
CZECH REPUBLIC
TEL: +420 255 719 326
FAX: +420 255 719 321

SAINT-GOBAIN ABRASIVES A/S
DYBENDALSVÆNGET 2,
DK-2630 TAASTRUP
DENMARK
TEL: +45 4675 5244

PO BOX 643706
FORTUNE TOWER OFFICE 2106
JLT BLOCK C
(NEXT TO METRO STATION)
JUMEIRA LAKE TOWER, DUBAI
UNITED ARAB EMIRATES
TEL: +971 4 431 5154
FAX: +971 4 431 5434

SAINT-GOBAIN ABRASIFS
RUE DE L'AMBASSADEUR - B.P.8
78 702 CONFLANS CEDEX
FRANCE
TEL: +33 (0)1 34 90 40 00
FAX: +33 (0)1 39 19 89 56

SAINT-GOBAIN ABRASIVES GMBH
BIRKENSTRASSE 45-49
D-50389 WESSELING
GERMANY
TEL: +49(0)2236703-1
+49(0)22368996-0
+49 (0)2236 8911-0
FAX: +49(0)2236703-367
+49(0)22368996-10
+49 (0) 2236 8911-30

FÜR DEN FACHHANDEL
ÖSTERREICH
TEL: +43 (00) 662 430 076

SAINT-GOBAIN ABRASIVES KFT.
1225 BUDAPEST
BÁNYALÉG U. 60/B.
HUNGARY
TEL: +36 1 371 22 50
FAX: +36 1 371 22 55

SAINT-GOBAIN ABRASIVI S.P.A
VIA PER CESANO BOSCONI 4
I-20094 CORSICO MILANO
ITALY
TEL: +39 02 44 851
FAX: +39 02 44 78 266

SAINT-GOBAIN ABRASIVES S.A.
190 RUE J.F. KENNEDY
L-4930 BASCHARAGE
GRAND DUCHE DE LUXEMBOURG
TEL: +352 50 401 1
FAX: +331 83 717 792
NO. VERT (FRANCE): 0800 906 903

SAINT-GOBAIN ABRASIFS, S.A.
2 ALLÉE DES FIGUIERS
AIN SEBAÄ - CASABLANCA
MOROCCO
TEL: +212 5 22 66 57 31
FAX: +212 5 22 35 09 65

SAINT-GOBAIN ABRASIVES BV
GROENLOSEWEG 28
7151 HW EIBERGEN
P.O. BOX 10
7150 AA EIBERGEN
THE NETHERLANDS
TEL: +31 545 466466
FAX: +31 545 474605

SAINT-GOBAIN ABRASIVES AS
KARIHAUGVEIEN, 89
0186 OSLO
NORWAY
TEL: +47 63 87 06 00
FAX: +47 63 87 06 01

SAINT-GOBAIN HPM POLSKA SP. Z O.O.
UL. NORTON 1, 62-600 KOŁO
62-600 KOŁO
POLAND
TEL: +48 63 26 17 100
FAX: +48 63 27 20 401

SAINT-GOBAIN ABRASIVOS, L. DA
ZONA INDUSTRIAL DA MAIA
I-SECTOR VIII, NO. 122
APARTADO 6050
4476 - 908 MAIA
PORTUGAL
TEL: +351 229 437 940
FAX: +351 229 437 949

SAINT-GOBAIN GLASS
BUSINESS UNIT ABRASIVI
PUNCT DE LUCRU : LOC.VETIS, JUD.
SATU MARE 447355
STR. CAREIULUI 11
PARC INDUSTRIAL RENOVATIO
ROMANIA
TEL: +40 261 839 709
FAX: +40 261 839 710

SG HPM RUS
58, F. ENGELS STR.
STROENIE 2
105082 MOSCOW
RUSSIA
TEL: +74 955 408 355
FAX: +74 959 373 224

SAINT-GOBAIN
ABRASIVES (PTY) LTD
2 MONTEER ROAD
ISANDO 1600
P.O. BOX 67
SOUTH AFRICA
TEL: +27 11 961 2000
FAX: +27 11 961 2184/5

SAINT-GOBAIN ABRASIVOS, S.A.
CTRA. DE GUIPÚZCOA, KM. 7,5
E-31195 BERRIOPLANO (NAVARRA)
SPAIN
TEL: +34 948 306 000
FAX: +34 948 306 042

SAINT GOBAIN ABRASIVES AB
GÅRDSFÖGDEVÄGEN 18A
168 66 BROMMA • SVERIGE
SWEDEN
TEL: +46 8 580 881 00
FAX: +46 8 580 881 30

SAINT-GOBAIN INOVATIF MALZEMELER VE
ASINDIRICI SAN. TIC. AS.
ALTAYÇEŞME MAH. ÇAMLI SOK. NO:21 ESAS
OFISPARK KAT:9 34843
MALTEPE, İSTANBUL • TURKEY
TEL: 0090-216-217 12 50
FAX: 0090-216-442 40 74

SAINT-GOBAIN ABRASIVES LTD.
UNICORN HOUSE UNIT 1, AMISON CLOSE
REDHILL BUSINESS PARK
STAFFORD ST161WB
UNITED KINGDOM
TEL: +44 1785 279 553



Saint-Gobain Abrasifs
190 Rue J.F. Kennedy
L-4930 Bascharage
Grand Duché de Luxembourg
Tel: +352 50 4011
Fax: +331 83 717 792
no. vert (France) 0800 906 903

www.nortonabrasives.com/fr-fr