

# CS 451 D7

SPARE PART LIST  
LISTE DE PIÈCES DE RECHANGE  
ERSATZTEILLISTE



**NORTON**  
SAINT-GOBAIN®

**clipper®**

**ENGLISH**

TYPE:

S = Spare part

W = Wear part

NA = Not Available

The kits of spare parts contain all screws and bolts and the components referring itself to it.

Screws and bolts is component of standard assembly, which you can easily find at all the retailers of standard components of assembly.

All the components of standard assembly are of a quality grade 8.8.

We recommend not to use a quality grade lower than 8.8 for all the standard components of assembly.

The parts of replacements Norton CLIPPER must always be used.

Wear parts life will vary based on usage and maintenance of the machine or part. Wear parts will need to be maintained and replaced as needed. No warranty is applied to wear parts.

The components NA (Not Available) are not available in spare part.

**FRANCAIS**

TYPE :

S = Pièce de rechange

W = Pièce d'usure

NA = Non disponible

Les kits de pièces détachées contiennent toute la visserie et les composants s'y rapportant.

La visserie est un composant d'assemblage standard, que vous pouvez facilement trouver chez tous les détaillants de composants d'assemblage standards.

Tous les composants d'assemblage standard sont d'une classe de qualité 8.8.

Nous recommandons de ne pas utiliser une classe de qualité inférieure à 8.8 pour tous les composants d'assemblage standards.

Pour les pièces non standard, les pièces de remplacement doivent impérativement provenir de Norton CLIPPER.

La durée de vie des pièces d'usure varie en fonction de l'utilisation et de la maintenance de la machine ou de la pièce. Les pièces d'usure devront être entretenues et remplacées au besoin. Aucune garantie n'est appliquée aux pièces d'usure.

Les composants NA (Not Available) ne sont pas disponibles en pièce de rechange.

**DEUTSCH**

TYP :

S = Ersatzteile

W = Verschleißteile

NA = nicht verfügbare

Die definierten Ersatzteil-Set's beinhalten alle Ersatzteile wie Komponenten, Schrauben, Muttern etc.

Norm- bzw. Standardteile wie Schrauben, Muttern etc. können bei offiziellen Schrauben- sowie Komponentenhändler bezogen werden.

Alle Norm- bzw. Standardteile wie Schrauben, Muttern etc. entsprechen der Qualitäts- bzw. Festigungsklasse 8.8.

Wir empfehlen, keine Norm- bzw. Standardteile wie Schrauben, Muttern etc. unter der Qualitäts- bzw.

Festigungsklasse 8.8 einzusetzen.

Es dürfen nur geprüfte Norton CLIPPER-Ersatzteile eingesetzt werden.

Die Lebensdauer der Verschleißteile hängt von der Verwendung und Wartung der Maschine oder des Teils ab. Verschleißteile müssen gewartet und bei Bedarf ersetzt werden. Für Verschleißteile wird keine Garantie übernommen.

Ersatzteile sowie Komponenten mit dem Vermerk NA (NA=nicht verfügbar) sind nicht verfügbar.

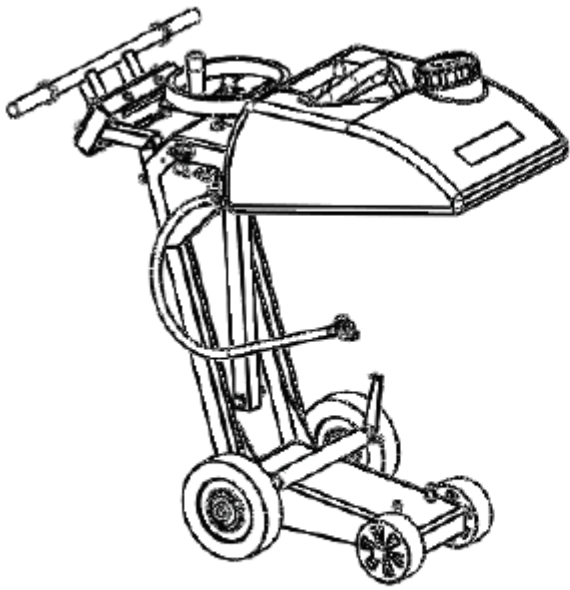

\_\_\_\_\_ Pages 4 - 7



\_\_\_\_\_ Pages 8 - 9

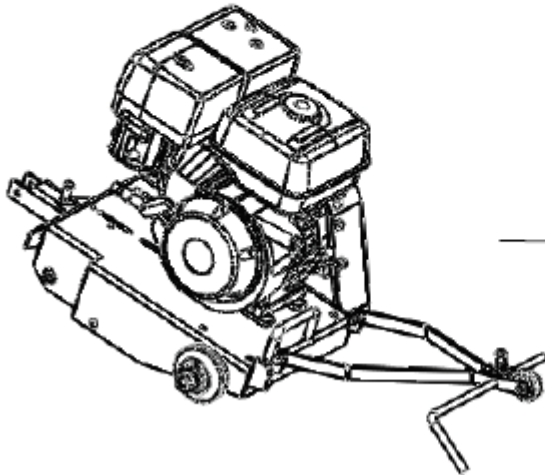

\_\_\_\_\_ Pages 10 - 13

# Main frame / Châssis principal / Hauptrahmen



Depends on the serial number of the machine

Dépend du numéro de série de la machine

Hängt von der Nummer von Serie der Maschine ab

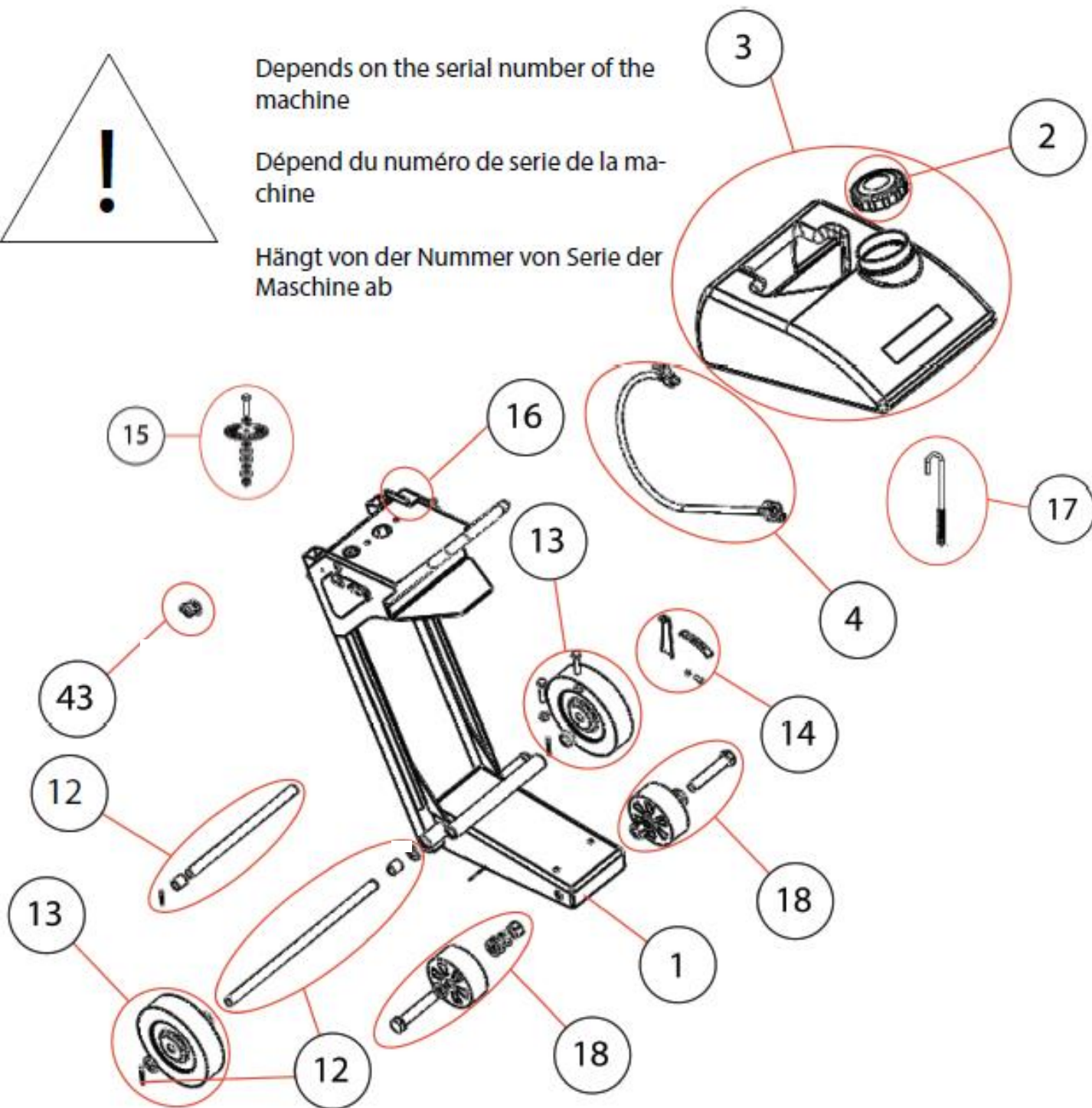

POS	DESCRIPTION	DESCRIPTION	BESCHREIBUNG	QTY	REF	TYPE
<b>1</b>	<b>Basic frame</b>	<b>Châssis fixe</b>	<b>Fester Rahmen</b>	<b>1</b>	<b>310353378</b>	<b>S</b>
	Basic frame	Châssis fixe	Fester Rahmen	1		
	screw DIN 933 – M10X35	vis DIN 933 – M10X30	Schraube DIN 933 – M10X35	2		
	nut DIN 934 - M10	ecrou DIN 934 - M10	Mutter DIN 934 - M10	2		
<b>2</b>	<b>Water tank cap</b>	<b>Bouchon réservoir d'eau</b>	<b>Wasserwanne Stopfen</b>	<b>1</b>	<b>310006560</b>	<b>S</b>
<b>3</b>	<b>Water tank assy.</b>	<b>Réservoir d'eau complet</b>	<b>Wasserwanne, kompl.</b>	<b>1</b>	<b>310562843</b>	<b>S</b>
	Water tank	Réservoir d'eau	Wasserwanne	1		
	Water tank cap	Bouchon réservoir d'eau	Wasserwanne Stopfen	1		
<b>4</b>	<b>Water connection</b>	<b>Connexion d'eau complète</b>	<b>Wasseranschluß, kompl.</b>	<b>1</b>	<b>310562844</b>	<b>W</b>
	Water pipe	Tuyau d'eau	Wasserschlauch	1		
	Gate valve	Robinet	Wasserhahn	1		
	Valve fitting	Raccord	Anschlussteile	1		
<b>12</b>	<b>Rear wheels axis kit (serial number up to 131015240)</b>	<b>Kit axe roues arrières (n° de série jusqu'à 131015240)</b>	<b>Hinterrad Achse Satz (Serien Nr. bis 131015240)</b>	<b>1</b>	<b>510112307</b>	<b>S</b>
	<b>Rear wheels axis kit (serial number from 131015240)</b>	<b>Kit axe roues arrières (n° de série depuis 131015240)</b>	<b>Hinterrad AchseSatz (Serien Nr. von 131015240)</b>	<b>1</b>	<b>510112308</b>	<b>S</b>
	washer DIN 125 - Ø21	rondelle DIN 125 - Ø21	Scheibe DIN 125 - Ø21	4		
	Polymer Bearings	Palier lisse polyamide	Polyamidgleitlager	2		
	Rear wheels axis 465x20 mm	Axe roue arrière 465x20 mm	Hinterrad Achse 465x20 mm	1		
	Ring 32x10 mm	Bague 32x10 mm	Ring 32x10 mm	1		
	splint PIN DIN94 4X40 ZINC	goupille DIN94 4X40 ZINC	Stift PIN DIN94 4X40 ZINC	2		
<b>13</b>	<b>Rear wheel kit</b>	<b>Kit roue arrière</b>	<b>Hinterrad Satz</b>	<b>1</b>	<b>510101399</b>	<b>W</b>
	Rear wheels Ø200	Roue arrière Ø200	Hinterrad Ø200	2		
	washer DIN 125 - Ø21	rondelle DIN 125 - Ø21	Scheibe DIN 125 - Ø21	4		
	splint PIN DIN94 4X40 ZINC	goupille DIN94 4X40 ZINC	Stift PIN DIN94 4X40 ZINC	2		
<b>14</b>	<b>Depth indicator kit (serial number from 131015240)</b>	<b>Kit indicateur de profondeur (n° de série depuis 131015240)</b>	<b>Schnittiefeanzeiger Satz</b>	<b>1</b>	<b>510126327</b>	<b>S</b>
	Depth indicator	Indicateur de profondeur	Schnittiefeanzeiger	1		
	Black metal part for sticker	support metal noir de sticker	Schwarzes Metallteil für Aufkleber	1		
	screw DIN 933 – M6X16	vis DIN 933 – M6X16	Schraube DIN 933 – M6X16	2		
	nut DIN EN ISO7040 - M6	ecrou DIN EN ISO7040 - M6	Mutter DIN EN ISO7040 - M6	2		
	washer DIN125 - Ø6.4	rondelle DIN125 - Ø6.4	Scheibe DIN125 - Ø6.4	4		
	screw DIN 933 – M6X16	vis DIN 933 – M6X16	Schraube DIN 933 – M6X16	1		
	nut DIN 934 - M6	ecrou DIN 934 - M6	Mutter DIN 934 - M6	1		
	Sticker depth indicator	Sticker gradué	graduierter Aufkleber	1		
<b>15</b>	<b>Depth indicator kit (serial number up to 131015240)</b>	<b>Kit indicateur de profondeur (n° de série jusqu'à 131015240)</b>	<b>Schnittiefeanzeiger Satz (Serien Nr. bis 131015240)</b>	<b>1</b>	<b>310006556</b>	<b>S</b>
	Depth indicator	Indicateur de profondeur	Schnittiefeanzeiger	1		
	screw DIN 933 – M12X40	vis DIN 933 – M12X40	Schraube DIN 933 – M12X45	1		
	washer DIN 125 - Ø13	rondelle DIN 125 - Ø13	Scheibe DIN 125 - Ø13	2		
	washer DIN 127 - W12	rondelle DIN 127 - W12	Scheibe DIN 127 - W12	2		
	nut DIN 985 - M12	ecrou DIN 985 - M12	Mutter DIN 985 - M12	1		
	Depth indicator finger and support	Indicateur de profondeur pointeur et support	Schnittiefeanzeiger Zeiger & Auflager	1		
	Bush spacer 28x22x22	Entretoise 28x22x22	Abstandsring 28x22x22	1		
	Ring Ø30xØ13x6	Bague Ø30xØ13x6	Ring Ø30xØ13x6	1		
<b>16</b>	<b>Handwheel lock (serial number from 131015240)</b>	<b>Blocage volant (n° de série depuis 131015240)</b>	<b>Blockierlenkrad</b>	<b>1</b>	<b>510126328</b>	<b>S</b>
	Locking plate	Plaque de blocage	Sperrplatte	1		
	screw DIN EN24017 - M10x35	vis DIN EN24017 - M10x35	Schraube DIN EN24017 - M10x35	1		
	nut DIN 934 - M10	ecrou DIN 934 - M10	Mutter DIN 934 - M10	1		
	nut ISO10511 - M10	ecrou ISO10511 - M10	Mutter ISO10511 - M10	1		
	washer DIN125 - Ø10,5	rondelle DIN125 - Ø10,5	Scheibe DIN125 - Ø10,5	2		
<b>17</b>	<b>Handwheel hook and spring (serial number up to 131015240)</b>	<b>Crochet volant + ressort (n° de série jusqu'à 131015240)</b>	<b>Schnittiefenarretierung + Feder (Serien Nr. bis 131015240)</b>	<b>1</b>	<b>310327609</b>	<b>S</b>
	Handwheel hook	Crochet volant	Schnittiefenarretierung	1		
	Spring	Ressort	Feder	1		
	nut DIN 934 - M8	ecrou DIN 934 - M8	Mutter DIN 934 - M8	2		
<b>18</b>	<b>Kit nose gear wheel complete</b>	<b>Kit roue avant complet</b>	<b>Vorderrad, kompl.</b>	<b>1</b>	<b>310602561</b>	<b>W</b>
	Front wheels Ø125	Roue avant Ø125	Vorderrad Ø125	2		
	screw DIN 933 – M20X100	vis DIN 933 – M20X100	Schraube DIN 933 – M20X100	2		
	washer DIN 125 - Ø21	rondelle DIN 125 - Ø21	Scheibe DIN 125 - Ø21	6		
	washer DIN 127 - W20	rondelle DIN 127 - W20	Scheibe DIN 127 - W20	2		
	nut DIN 934 - M20	ecrou DIN 934 - M20	Mutter DIN 934 - M20	2		
<b>43</b>	<b>Switch</b>	<b>Interrupteur</b>	<b>Schalter</b>	<b>1</b>	<b>310006610</b>	<b>S</b>

# Operating handle/ Poignée de manoeuvre / Handgriff:

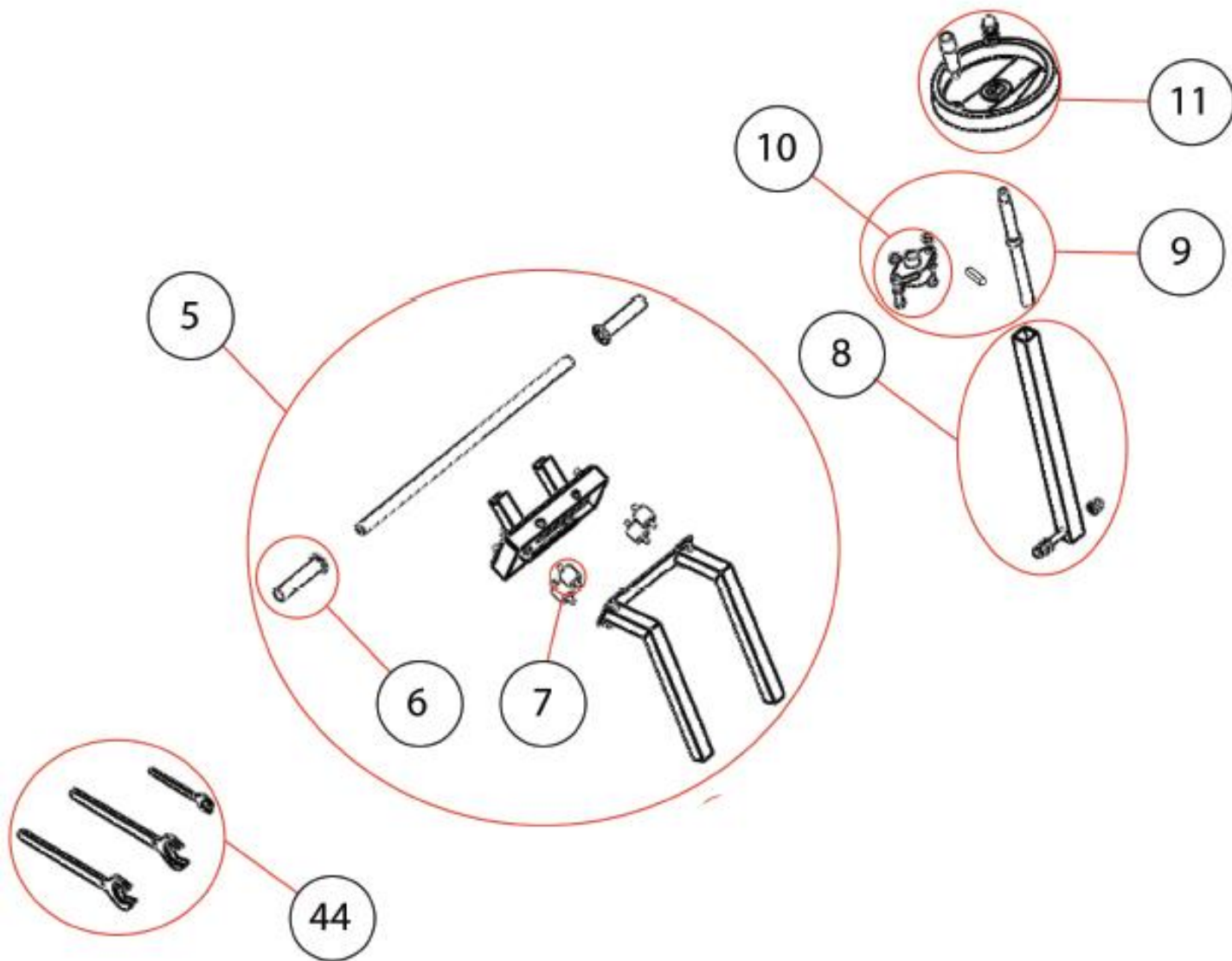

POS	DESCRIPTION	DESCRIPTION	BESCHREIBUNG	QTY	REF	TYPE
5	<b>Operating handle assy.</b>	<b>Poignée de manœuvre complète</b>	<b>Schalhandgriff, kompl.</b>	1	310353379	S
	Rubber handle	Poignée caoutchouc	Gummi Handgriff	2		
	Handlebars	Guidon	Fahradlenker	1		
	Silentbloc	Silentbloc	Schwingungsdämpfer	4		
	nut DIN 1587 - M8	ecrou DIN 1587 - M8	Mutter DIN 1587 - M8	8		
	washer DIN127 - M8	rondelle DIN127 - M8	Scheibe DIN127 - M8	8		
	washer ISO7089 - M8	rondelle ISO7089 - M8	Scheibe ISO7089 - M8	8		
	fork	Fourche	Gabel	1		
	screw DIN 933 – M10X25	vis DIN 933 – M10X25	Schraube DIN 933 – M10X25	2		
	nut DIN 934 - M10	ecrou DIN 934 M10	Mutter DIN 934 - M10	2		
	Try square	Equerre de butée	Anschlagwinkel	2		
	screw ISO7380 M8x20	vis ISO7380 M8x20	Schraube ISO7380 M8x20	4		
	washer DIN127 - M8	rondelle DIN127 - M8	Scheibe DIN127 - M8	4		
	washer ISO7089 - M8	rondelle ISO7089 - M8	Scheibe ISO7089 - M8	4		
6	<b>Rubber handle</b>	<b>Poignée en caoutchouc</b>	<b>Gummi Handgriffe</b>	1	310004190	S
7	<b>Silentbloc (jeu de 4)</b>	<b>Silentbloc (jeu de 4)</b>	<b>Schwingungsdämpfer (Satz von 4Stk)</b>	1	310353381	W
8	<b>Screw feed spindle assy.</b>	<b>Tige de relevage complet</b>	<b>Spindelrohr, kompl.</b>	1	310006553	S
	screw feed spindle	Tige de relevage	Spindelrohr, kompl.	1		
	screw DIN 931 – M12X65	vis DIN 931 – M12X65	Schraube DIN 931 – M12X65	1		
	washer DIN 125 - Ø13	rondelle DIN 125 - Ø13	Scheibe DIN 125 - Ø13	4		
	nut ISO10511 - M12	ecrou ISO10511 - M12	Mutter ISO10511 - M12	1		
9	<b>Raise lower screw</b>	<b>vis de relevage</b>	<b>Spindelschraube</b>	1	510101473	S
	Raise lower screw	vis de relevage	Spindelschraube	1		
	Cotter B6X6X28 DIN 6889	Clavette B6X6X28 DIN 6889	Keil B6X6X28 DIN 6889	1		
	screw DIN 933 – M10X35	vis DIN 933 – M10X35	Schraube DIN 933 – M10X35	2		
	washer DIN 125 - Ø10,5	rondelle DIN 125 - Ø10,5	Scheibe DIN 125 - Ø10,5	4		
	washer DIN 127 - W10	rondelle DIN 127 - W10	Scheibe DIN 127 - W10	2		
	nut DIN 934 - M10	ecrou DIN 934 - M10	Mutter DIN 934 - M10	2		
	Bearing FYTB 20 TF	PALIER FYTB 20 TF	Lager FYTB 20 TF	1		
10	<b>Bearing FYTB 20 TF kit</b>	<b>Kit palier FYTB 20 TF</b>	<b>Lager FYTB 20 TF kit</b>	1	310004907	W
	Bearing FYTB 20 TF	PALIER FYTB 20 TF	Lager F FYTB 20 TF	1		
	screw DIN 933 – M10X35	vis DIN 933 – M10X35	Schraube DIN 933 – M10X35	2		
	washer DIN 125 - Ø10,5	rondelle DIN 125 - Ø10,5	Scheibe DIN 125 - Ø10,5	4		
	washer DIN 127 - W10	rondelle DIN 127 - W10	Scheibe DIN 127 - W10	2		
	nut DIN 934 - M10	ecrou DIN 934 - M10	Mutter DIN 934 - M10	2		
11	<b>Handwheel assy</b>	<b>Volant complet</b>	<b>Lenkrad, kompl.</b>	1	510101420	S
	Handwheel	Volant	Lenkrad	1		
	Handle	Poignée	Griff	1		
	nut DIN 1587 - M16	ecrou DIN 1587 - M16	Mutter DIN 1587 - M16	1		
	washer DIN127 - M16	rondelle DIN127 - M16	Scheibe DIN127 - M16	1		
	washer ISO7089 - M16	rondelle ISO7089 - M16	Scheibe ISO7089 - M16	1		
44	<b>Toolkit</b>	<b>Kit outils</b>	<b>Maulschlüssel Satz</b>	1	510101471	S
	Wrench 36mm	Clé 36mm	Maulschlüssel 36 mm	1		
	Wrench 30mm	Clé 30mm	Maulschlüssel 30 mm	1		
	Wrench 17mm	Clé 17mm	Maulschlüssel 17 mm	1		

# Blade guard / Carter de disque / Plattegehäuse:

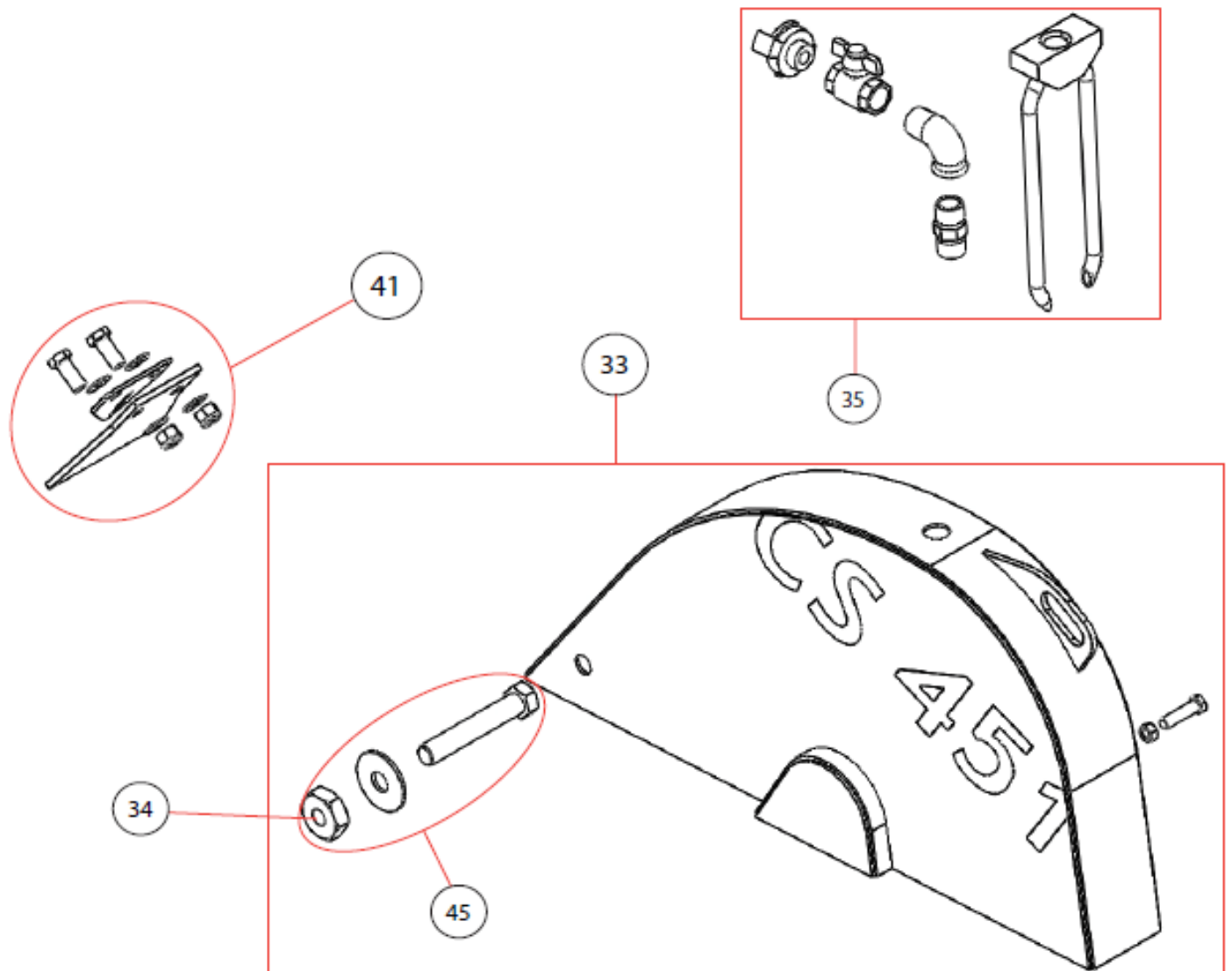

POS	DESCRIPTION	DESCRIPTION	BESCHREIBUNG	QTY	REF	TYPE
<b>33</b>	<b>Blade guard kit</b>	<b>Kit carter de lame</b>	<b>Messergehäuse Satz</b>	<b>1</b>	<b>310562841</b>	<b>S</b>
	Blade guard	Carter de lame	Messergehäuse	1		
	screw DIN931 M16X100	vis DIN931 M16X100	Schraube DIN931 M16X100	1		
	washer DIN125-17 PLATE	rondelle DIN125-17 PLATE	Scheibe DIN125-17 PLATE	1		
	nut - M16	ecrou - M16	Mutter - M16	1		
	screw DIN933 M10X30	vis DIN933 M10X30	Schraube DIN933 M10X30	1		
	nut DIN934 M10 H. ZINGUE	ecrou DIN934 M10 H. ZINGUE	Mutter DIN934 M10 H. ZINGUE	1		
<b>34</b>	<b>Nut - M16</b>	<b>Ecrou - M16</b>	<b>Mutter - M16</b>	<b>1</b>	<b>310004181</b>	<b>S</b>
<b>35</b>	<b>Watering system</b>	<b>Système d'arrosage</b>	<b>Bewassersystem</b>	<b>1</b>	<b>310562842</b>	<b>W</b>
	Distributor	Repartiteur busettes	Büsenverteiler	1		
	Watering nozzle	Busette d'arrosage	Düsenbewässern	2		
	ELBOW R 1/2"GF NR 92-90° GALV	Coude R 1/2"GF NR 92-90° GALV	Winckel R 1/2"GF NR 92-90° GALV	1		
	Gate valve 1/2" FEM/FEM	Robinet 1/2" FEM/FEM	Wasserhahn 1/2" gew./ gew.	1		
	Geka valve fitting	Raccord GEKA	GEKA Schlauchkupplung	1		
<b>41</b>	<b>Splash guard kit</b>	<b>Kit bavette</b>	<b>Spritzschutzlappen Satz</b>	<b>1</b>	<b>310006566</b>	<b>W</b>
	Splash guard	Bavette	Spritzlappen	1		
	Rear cutting-guide	Guide de coupe arriere	Rück Schnittführung	1		
	screw DIN933 M10X25	vis DIN933 M10X25	Schraube DIN933 M10X25	2		
	washer DIN 125 - Ø10,5	rondelle DIN 125 - Ø10,5	Scheibe DIN 125 - Ø10,5	4		
	nut ISO10511 - M10	ecrou ISO10511 - M10	Mutter ISO10511 - M10	2		
<b>45</b>	<b>Axis of pivot complete</b>	<b>Axe de pivot complet</b>	<b>Schwenkachse, kompl.</b>	<b>1</b>	<b>510101475</b>	<b>W</b>
	Axis of pivot	Axe de pivot	Schwenkachse	1		
	washer DIN 125 - Ø17 / Ø50	rondelle DIN 125 - Ø17 / Ø50	Scheibe DIN 125 - Ø17 / Ø50	1		
	nut - M16	ecrou - M16	Mutter - M16	1		

# Motor / Moteur / Motor

Depends on the serial number  
of the machine

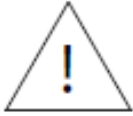

Dépend du numéro de série de  
la machine

Hängt von der Nummer von  
Serie der Maschine ab

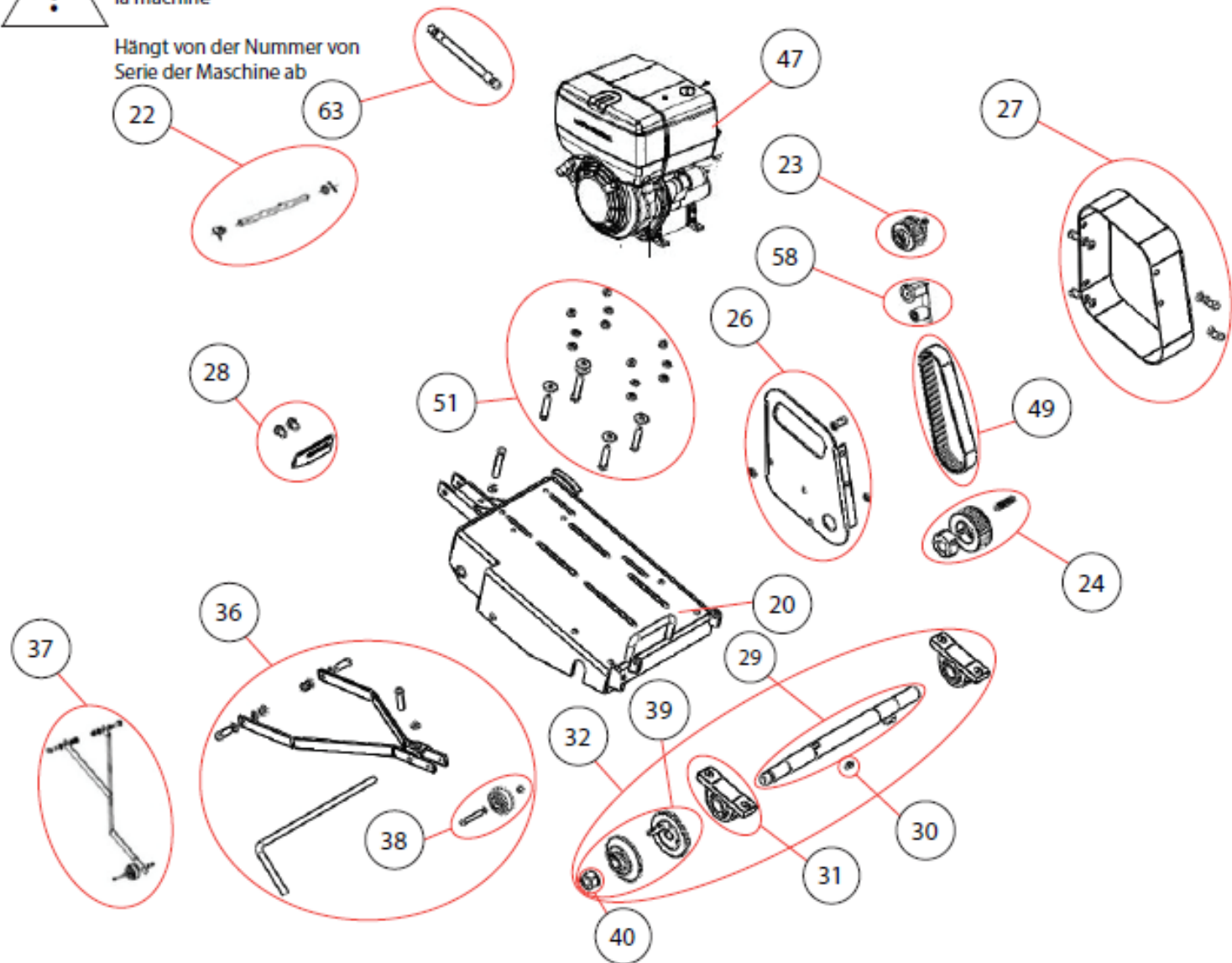

POS	DESCRIPTION	DESCRIPTION	BESCHREIBUNG	QTY	REF	TYPE
20	<b>Motor frame kit</b>	<b>Kit support moteur</b>	<b>Motorträger Satz</b>	1	510126330	S
	Motor frame	Support moteur	Motorträger	1		
	screw abutment of lifting	vis butée de relevage DIN 933 M10x75	Einstellspindel Anschlagschrauben DIN 933 M10x75	1		
22	<b>Axis motor frame kit (serial number up to 131015240)</b>	<b>Kit axe support moteur (n° de série jusqu'à 131015240)</b>	<b>Motorträgerachses (Serien Nr. bis 131015240)</b>	1	310006568	S
	Motor frame axle	Axe support moteur	Achse	1		
	Ring Iglidur GFM-2023-11	Bague Iglidur GFM-2023-11	Ring Iglidur GFM-2023-11	2		
	Wear ring 20x23x25	Bague d'usure 20x23x25	Schleißring 20x23x25	2		
22	<b>Axis motor frame kit (serial number from 131015240)</b>	<b>Kit axe support moteur (n° de série depuis 131015240)</b>	<b>Motorträgerachses (Serien Nr. von 131015240)</b>	1	510109503	S
	Axis Ø20	Axe Ø20	Achse Ø20	1		
	Ring Iglidur GFM-2023-11	Bague Iglidur GFM-2023-11	GFM-2023-11 Iglidur Ring	2		
	SPLINT PIN DIN94 4X40 ZINC	Goupille DIN94 4X40 ZINC	Stift DIN94 4X40 ZINC	2		
23	<b>Motor pulley kit</b>	<b>Kit poulie moteur</b>	<b>Motorriemenscheibe Satz</b>	1	510126331	S
	PULLEY POLY-V 10PK Ø67	POULIE POLY-V 10PK Ø67	POLY-V 10PK Ø67 Riemenscheibe	1		
	Key 1/4" x 1/4" x 1.5" DIN 6885	CLAVETTE 1/4" x 1/4" x 1.5" DIN 6885	1/4" x 1/4" x 1.5" DIN 6885 Keil	1		
	SPACER	Bague intermédiaire	Zwischenring	1		
	LOCKING RING	Bague de blocage	Blockierring	1		
	screw ISO4026 - M8x8	vis ISO4026 - M8x8	Schraube ISO4026 - M8x8	2		
24	<b>Blade shaft pulley kit</b>	<b>Kit poulie arbre de meule</b>	<b>Riemenscheibe Schneidwelle Satz</b>	1	510126332	S
	PULLEY POLY-V 10PK Ø95	POULIE POLY-V 10PK Ø95	POLY-V 10PK Ø95 Riemenscheibe	1		
	REMOVABLE HUB Ø28	Moyeu amovible Ø28	Ø28 Ablösbar Nabe	1		
	KEY A8X7X55 DIN 6885	Clavette A8X7X55 DIN 6885	A8X7X55 DIN 6885 Keil	1		
	screw ISO4026 - M10x16	vis ISO4026 - M10x16	Schraube ISO4026 - M10x16	2		
26	<b>Fixed belt guard kit CS451 D7</b>	<b>Kit carter fixe courroie CS451 D7</b>	<b>Festes RiemenschutzSatz CS451 D7</b>	1	510140012	S
	Fixed belt guard	Carter fixe	Festes Riemenschutz	1		
	screw DIN 933 – M10X25	vis DIN 933 – M10X25	Schraube DIN 933 – M10X25	3		
	washer DIN 125 - Ø10,5	rondelle DIN 125 - Ø10,5	Scheibe DIN 125 - Ø10,5	3		
	washer DIN 127 - W10	rondelle DIN 127 - W10	Scheibe DIN 127 - W10	3		
27	<b>Mobile belt guard kit CS451 D7</b>	<b>Kit carter mobile courroie CS451 D7</b>	<b>Ablösbar Riemenschutz Satz CS451 D7</b>	1	510140013	S
	Loose belt guard	Carter mobile	Ablösbar Riemenschutz	1		
	screw DIN 933 – M10X20	vis DIN 933 – M10X20	Schraube DIN 933 – M10X20	4		
	washer DIN 125 - Ø10,5	rondelle DIN 125 - Ø10,5	Scheibe DIN 125 - Ø10,5	4		
	washer DIN 6797 - Ø10,5	rondelle DIN 6797 - Ø10,5	Scheibe DIN 6797 - Ø10,5	4		
28	<b>Parking brake kit</b>	<b>Kit frein de parking</b>	<b>Parkingbremse Satz</b>	1	310353508	S
	Braking plate	Plaque de freinage	Bremsplatte	1		
	screw DIN 933 – M10X20	vis DIN 933 – M10X20	Schraube DIN 933 – M10X20	2		
	washer DIN 125 - Ø10,5	rondelle DIN 125 - Ø10,5	Scheibe DIN 125 - Ø10,5	2		
	washer DIN 6797 - Ø10,5	rondelle DIN 6797 - Ø10,5	Scheibe DIN 6797 - Ø10,5	2		
29	<b>Blade shaft kit</b>	<b>Kit arbre de meule</b>	<b>Schleifscheiben Achse Satz</b>	1	310562839	S
	Blade shaft	Arbre de meule	Schleifscheiben Achse	1		
	KEY A8x7x20 DIN6885	Clavette A8x7x20 DIN6885	Keil A8X7X20 DIN 6885	1		
30	<b>KEY A8x7x20 DIN6885</b>	<b>Clavette A8x7x20 DIN6885</b>	<b>Passfeder A8X7X20 DIN 6885</b>	1	510005688	S
31	<b>Bearing kit</b>	<b>Kit palier arbre de meule</b>	<b>Schneidwellenlager kit</b>	1	310004295	W
	Bearing	Palier à semelle	Schneidwellenlager	2		
	washer DIN7349-13	rondelle DIN7349-13	Scheibe DIN7349-13	4		
	washer DIN128 A12	rondelle DIN128 A12	Scheibe DIN128 A12	4		
	washer DIN125-A13	rondelle DIN125-A13	Scheibe DIN125-A13	4		
	screw DIN931 M12X45	vis DIN931 M12X45	Schraube DIN931 M12X45	4		
	nut DIN24032 M12	ecrou DIN24032 M12	Mutter DIN24032 M12	4		

# Motor / Moteur / Motor

Depends on the serial number  
of the machine

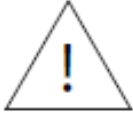

Dépend du numéro de série de  
la machine

Hängt von der Nummer von  
Serie der Maschine ab

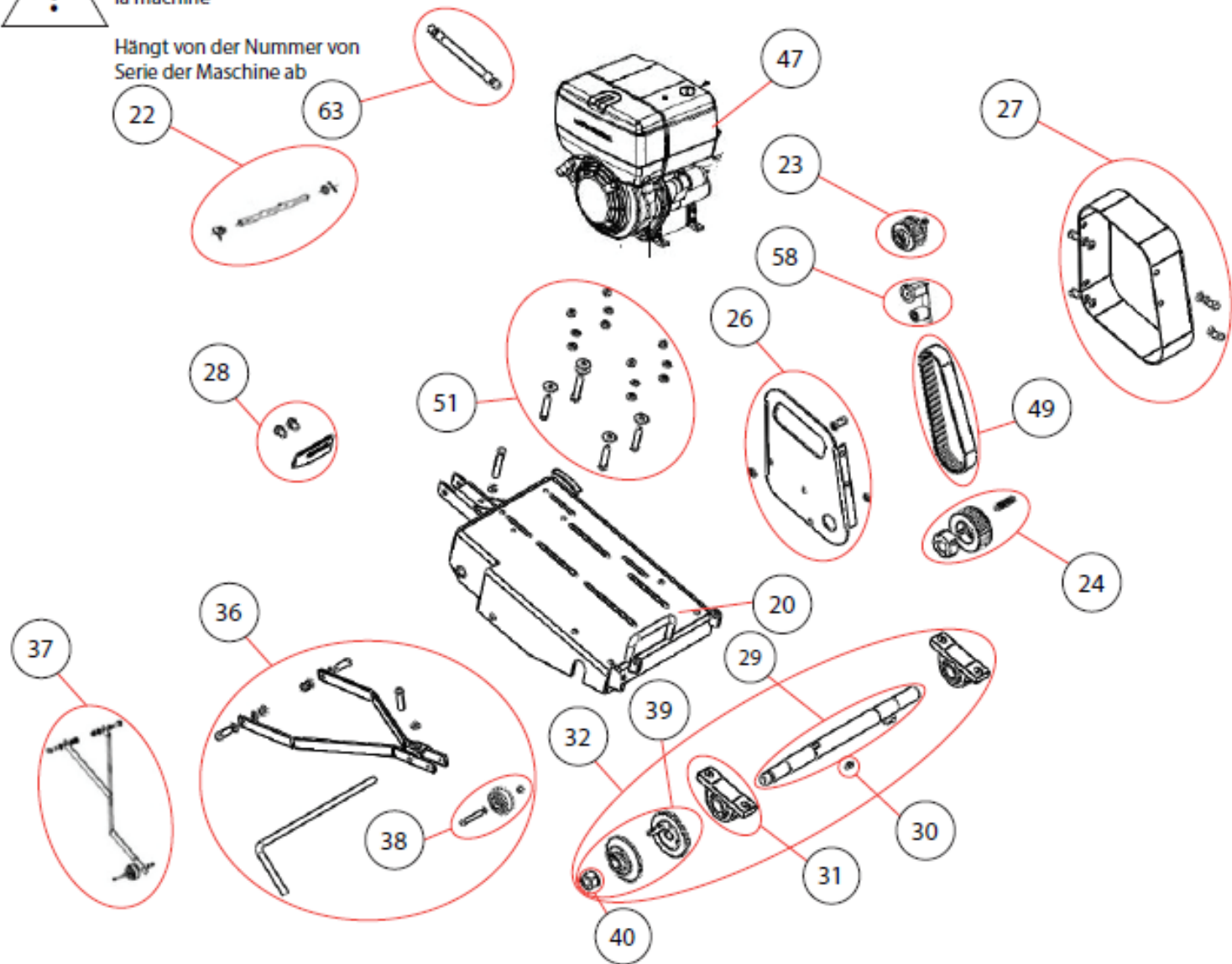

POS	DESCRIPTION	DESCRIPTION	BESCHREIBUNG	QTY	REF	TYPE
32	<b>Assembled blade shaft kit</b>	<b>Kit arbre de meule prémonté</b>	<b>Satz vorfertigter Mühlsteinbaum</b>	1	510101480	S
	Blade shaft	Arbre de meule	Schneidwelle	1		
	Bearing	Palier à semelle	Schneidwellenlager	2		
	washer DIN7349-13	rondelle DIN7349-13	Scheibe DIN7349-13	4		
	washer DIN128 A12	rondelle DIN128 A12	Scheibe DIN128 A12	4		
	washer DIN125-A13	rondelle DIN125-A13	Scheibe DIN125-A13	4		
	screw DIN931 M12X45	vis DIN931 M12X45	Schraube DIN931 M12X45	4		
	nut DIN24032 M12	écrou DIN24032 M12	Mutter DIN24032 M12	4		
	Fixed flange	Flasque fixe	Loser Flansch	1		
	Mobile flange	Flasque mobile	Fester Flansch	1		
	nut	écrou de serrage	SchneidwellenMutter	1		
	KEY A8x7x20 DIN6885	Clavette A8x7x20 DIN6885	Passfeder A8X7X20 DIN 6885	1		
	Spring pins DIN 1481 - 10X45	Goupilles élastiques fendues DIN 1481 - 10X45	Spannhülsen DIN 1481 - 10X45	1		
36	<b>Cutting guide assy. (serial number from 131015240)</b>	<b>Guide de coupe complet (n° de série à partir de 131015240)</b>	<b>Richtungsanzeiger, kompl. (Nr. von Serie ab 131015240)</b>	1	510112310	S
	Cutting-guide	Guide de coupe	Richtungsanzeiger	1		
	Cutting-guide support	Support guide de coupe	Support führt von Schüssel	1		
	Wheel Ø75x30	Roue Ø75x30	Rad Ø75x30	1		
	Wheels axis 30x12 mm	Axe roue 30x12 mm	Radachse 30x12 mm	1		
	screw DIN24017 - M10x30	vis DIN933 - M10x30	Schraube DIN24017 - M10x30	2		
	washer DIN125 - Ø10.5	rondelle DIN125 - Ø10.5	Scheibe DIN125 - Ø10.5	6		
	nut DIN EN ISO7040 - M10	écrou DIN EN ISO7040 - M10	Mutter DIN EN ISO7040 - M10	2		
	screw DIN24017 - M6x55	vis DIN 912 - M6x55	Schraube DIN24017 - M6x55	1		
	washer DIN125 - Ø6.4	rondelle DIN125 - Ø6.4	Scheibe DIN125 - Ø6.4	2		
	nut DIN EN ISO7040 - M6	écrou DIN EN ISO7040 - M6	Mutter DIN EN ISO7040 - M6	1		
	screw DIN24017 - M10x35	vis DIN933 - M10x35	Schraube DIN24017 - M10x35	1		
	nut DIN24032 - M10	écrou DIN 934 - M10	Mutter DIN24032 - M10	1		
37	<b>Cutting guide assy. (serial number up to 131015240)</b>	<b>Guide de coupe complet (n° de série jusqu'à 131015240)</b>	<b>Richtungsanzeiger, kompl. (Nr. von Serie bis zu 131015240)</b>	1	310353451	S
	Cutting guide assy.	Guide de coupe complet	Richtungsanzeiger, kompl	1		
	Wheel Ø75x30	Roue Ø75x30	Rad Ø75x30	1		
	screw DIN 933 – M10X25	vis DIN 933 – M10X25	Schraube DIN 933 – M10X25	2		
	washer DIN 125 - Ø10,5	rondelle DIN 125 - Ø10,5	Scheibe DIN 125 - Ø10,5	4		
	washer DIN 127 - W10	rondelle DIN 127 - W10	Scheibe DIN 127 - W10	2		
	nut DIN 934 - M10	écrou DIN 934 - M10	Mutter DIN 934 - M10	2		
	screw DIN 7380 – M6X40	vis DIN 7380 – M6X40	Schraube DIN 7380 – M6X40	1		
	washer DIN 125 - Ø6,3	rondelle DIN 125 - Ø6,3	Scheibe DIN 125 - Ø6,3	1		
	washer DIN 127 - W6	rondelle DIN 127 - W6	Scheibe DIN 127 - W6	1		
	nut DIN 934 - M6	écrou DIN 934 - M6	Mutter DIN 934 - M6	1		
38	<b>Cutting-guide wheel kit</b>	<b>Kit roue guide de coupe</b>	<b>Rad des richtungsanzeiger kit</b>	1	510126339	S
	Wheel Ø75x30	Roue Ø75x30	Rad Ø75x30	1		
	Wheels axis 30x12 mm	Axe roue 30x12 mm	Radachse 30x12 mm	1		
	screw DIN24017 - M6x55	vis DIN 912 - M6x55	Schraube DIN24017 - M6x55	1		
	washer DIN125 - Ø6.4	rondelle DIN125 - Ø6.4	Scheibe DIN125 - Ø6.4	2		
	nut DIN EN ISO7040 - M6	écrou DIN EN ISO7040 - M6	Mutter DIN EN ISO7040 - M6	1		
39	<b>Flanges + nut kit</b>	<b>Kit flasques + écrou</b>	<b>Flansch + Mutter kit</b>	1	310562840	S
	Fixed flange	Flasque fixe	Loser Flansch	1		
	Mobile flange	Flasque mobile	Fester Flansch	1		
	nut	écrou de serrage	SchneidwellenMutter	1		
	KEY A8x7x20 DIN6885	Clavette A8x7x20 DIN6885	Passfeder A8X7X20 DIN 6885	1		
	Spring pins DIN 1481 - 10X45	Goupilles élastiques fendues DIN 1481 - 10X45	Spannhülsen DIN 1481 - 10X45	1		
40	<b>Flange's nut</b>	<b>écrou de flasque</b>	<b>SchneidwellenMutter</b>	1	310004269	S
47	<b>Motor HATZ D7 1B30 2-168C</b>	<b>Moteur HATZ D7 1B30 2-168C</b>	<b>Motor HATZ D7 1B30 2-168C</b>	1	510003887	S
49	<b>Belt POLY-V 10 PK 841mm</b>	<b>Courroie POLY-V 10 PK 841mm</b>	<b>Keilriemen POLY-V 10 PK 841mm</b>	1	310360982	W
51	<b>Fixing ENGINE HATZ 1B30</b>	<b>Fixation MOTEUR HATZ 1B30</b>	<b>Befestigung MOTORISCH HATZ 1B30</b>	1	310006578	S
58	<b>Complete tensioner</b>	<b>Tendeur COMPLET</b>	<b>VOLLSTÄNDIGES SPANNSTÜCK</b>	1	310004016	S
63	<b>Oil hose M22X1,5</b>	<b>Tuyau vidange d'huile M22X1,5</b>	<b>Oelablassschlauch M22x1,5</b>	1	310327819	S

# Stickers / Autocollants / Aufkleber



POS	DESCRIPTION	DESCRIPTION	BESCHREIBUNG	QTY	REF	TYPE
<b>64</b>	<b>Sticker kit</b>	<b>Kit d'autocollants</b>	<b>AufkleberSatz</b>	<b>1</b>	<b>510131238</b>	<b>S</b>
	White arrow	Flèche blanche	Weißer Pfeil	3		
	4 pictograms	4 pictogrammes	4 Piktogramme	1		
	Right side	Flanc droit	gerade Flanke	1		
	Left side	Flanc gauche	linke Flanke	1		
	Norton Clipper Logo Blade guard	Norton Clipper carter de disque	Norton Clipper Plattegehäuse	1		
	Norton Clipper Logo Blade guard back	Norton Clipper carter de disque arrière	Norton Clipper Hinterplattegehäuse	1		
	Logo 3 bands	Logo 3 bandes	Logo 3 Bänder	1		
	Risk of feet cut	Risque de coupure pied	Fußschnittgefahr	1		
	Prohibited lifting	Levée interdite	Verbotener Auftrieb	1		
	STOP	STOP	STOP	1		
	DISPLACEMENT MACHINE	Déplacement machine	VERSCHIEBUNGSMASCHINE	1		
	BLADE DESCENT	Descente de disque	BLATT-ABFALL	1		
	BLADE RISING	Montée de disque	BLATT-STEIGEN	1		

SAINT-GOBAIN ABRASIVES  
INDUSTRIEWEG 21  
9420 ERPE-MERE  
BELGIUM  
TEL: +32(0) 2 267 21 00

SAINT-GOBAIN ABRASIVES, S.R.O.  
POČERNICKÁ 272/96, MALEŠICE  
108 00 PRAHA 10  
CZECH REPUBLIC  
TEL: +420 255 719 326  
FAX: +420 255 719 321

SAINT-GOBAIN ABRASIVES A/S  
DYBENDALSVEENGET 2,  
DK-2630 TAASTRUP  
DENMARK  
TEL: +45 4675 5244

SAINT-GOBAIN ABRASIVES MIDDLE EAST  
JEBEL ALI FREE ZONE,  
PLOT NO. S10817  
PO BOX 261484, DUBAI •  
UNITED ARAB EMIRATES  
TEL: +971 (4) 8011 800  
FAX: +971 (4) 8011 801

SAINT-GOBAIN ABRASIFS  
RUE DE L'AMBASSADEUR - B.P.8  
78 702 CONFLANS CEDEX  
FRANCE  
TEL: +33 (0)1 34 90 40 00  
FAX: +33 (0)1 39 19 89 56

SAINT-GOBAIN ABRASIVES GMBH  
BIRKENSTRASSE 45-49  
D-50389 WESSELING  
GERMANY  
TEL: +49 (0) 2236 703-1  
+49 (0) 2236 8996-0  
+49 (0) 2236 8911-0  
FAX: +49 (0) 2236 703-367  
+49 (0) 2236 8996-10  
+49 (0) 2236 8911-30

FÜR DEN FACHHANDEL  
ÖSTERREICH  
TEL: +43 (00) 662 430 076

SAINT-GOBAIN ABRASIVES KFT.  
1225 BUDAPEST  
BÁNYALÉG U. 60/B.  
HUNGARY  
TEL: +36 1 371 22 50  
FAX: +36 1 371 22 55

SAINT-GOBAIN ABRASIVI S.P.A  
VIA PER CESANO BOSCONI 4  
I-20094 CORSICO MILANO  
ITALY  
TEL: +39 02 44 851  
FAX: +39 02 44 78 266

SAINT-GOBAIN ABRASIVES S.A.  
190 RUE J.F. KENNEDY  
L-4930 BASCHARAGE  
GRAND DUCHE DE LUXEMBOURG  
TEL: +352 50 401 1  
FAX: +331 83 717 792  
NO. VERT (FRANCE): 0800 906 903

SAINT-GOBAIN ABRASIFS, S.A.  
2 ALLÉE DES FIGUIERS  
AIN SEBAA - CASABLANCA  
MOROCCO  
TEL: +212 5 22 66 57 31  
FAX: +212 5 22 35 09 65

SAINT-GOBAIN ABRASIVES BV  
GROENLOSEWEG 28  
7151 HW EIBERGEN  
P.O. BOX 10  
7150 AA EIBERGEN  
THE NETHERLANDS  
TEL: +31 545 466466  
FAX: +31 545 474605

SAINT-GOBAIN ABRASIVES AS  
POSTBOKS 11, ALNABRU, 0614 OSLO  
BROBEKKVEIEN 84,  
0582 OSLO • NORWAY  
TEL: +47 63 87 06 00  
FAX: +47 63 87 06 01

SAINT-GOBAIN HPM POLSKA SP. Z O.O.  
UL. NORTON 1,  
62-600 KOŁO • POLAND  
TEL: +48 63 26 17 100  
FAX: +48 63 27 20 401

SAINT-GOBAIN ABRASIVOS, L. DA  
ZONA INDUSTRIAL DA MAIA  
I-SECTOR VIII, NO. 122  
APARTADO 6050  
4476 - 908 MAIA  
PORTUGAL  
TEL: +351 229 437 940  
FAX: +351 229 437 949

SAINT-GOBAIN GLASS  
BUSINESS UNIT ABRASIVI  
PUNCT DE LUCRU : LOC.VETIS, JUD.  
SATU MARE 447355  
STR. CAREIULUI 11  
PARC INDUSTRIAL RENOVATIO  
ROMANIA  
TEL: +40 261 839 709  
FAX: +40 261 839 710

SG HPM RUS  
58, F. ENGELS STR.  
STROENIE 2  
105082 MOSCOW  
RUSSIA  
TEL: +74 955 408 355  
FAX: +74 959 373 224

SAINT-GOBAIN  
ABRASIVES (PTY) LTD  
2 MONTEER ROAD  
ISANDO 1600  
P.O. BOX 67  
SOUTH AFRICA  
TEL: +27 11 961 2000  
FAX: +27 11 961 2184/5

SAINT-GOBAIN ABRASIVOS, S.A.  
CTRA. DE GUIPÚZCOA, KM. 7,5  
E-31195 BERRIOPLANO (NAVARRA)  
SPAIN  
TEL: +34 948 306 000  
FAX: +34 948 306 042

SAINT GOBAIN ABRASIVES AB  
GÅRDSFOGDEVÄGEN 18A  
168 66 BROMMA • SVERIGE  
SWEDEN  
TEL: +46 8 580 881 00  
FAX: +46 8 580 881 30

SAINT-GOBAIN INOVATIF MALZEMELER VE  
ASINDIRICI SAN. TIC. AS.  
ALTAYÇEŞME MAH. ÇAMLI SOK. NO:21 ESAS  
OFISPARK KAT:9 34843  
MALTEPE, İSTANBUL • TURKEY  
TEL: 0090-216-217 12 50  
FAX: 0090-216-442 40 74

SAINT-GOBAIN ABRASIVES LTD.  
DOXEY RD  
STAFFORD  
ST16 1EA  
UNITED KINGDOM  
TEL: +44 1785 222 000  
FAX: +44 1785 213 487



Saint-Gobain Abrasifs  
190 Rue J.F. Kennedy  
L-4930 Bascharage  
Grand Duché de Luxembourg  
Tel: +331 83 717 792  
Fax: +352 50 16 33  
no. vert (France) 0800 906 903