

NORTON

SAINT-GOBAIN

clipper

Transforming
surfaces
...and beyond

CM 42 D

SPARE PART LIST
LISTE DE PIÈCES DE RECHANGE
ERSATZTEILLISTE



SAINT-GOBAIN

ENGLISH

TYPE:

S = Spare part

W = Wear part

NA = Not Available

The kits of spare parts contain all screws and bolts and the components referring itself to it.

Screws and bolts is component of standard assembly, which you can easily find at all the retailers of standard components of assembly.

All the components of standard assembly are of a quality grade 8.8.

We recommend not to use a quality grade lower than 8.8 for all the standard components of assembly.

The parts of replacements Norton CLIPPER must always be used.

Wear parts life will vary based on usage and maintenance of the machine or part. Wear parts will need to be maintained and replaced as needed. No warranty is applied to wear parts.

The components NA (Not Available) are not available in spare part.

FRANCAIS

TYPE :

S = Pièce de rechange

W = Pièce d'usure

NA = Non disponible

Les kits de pièces détachées contiennent toute la visserie et les composants s'y rapportant.

La visserie est un composant d'assemblage standard, que vous pouvez facilement trouver chez tous les détaillants de composants d'assemblage standards.

Tous les composants d'assemblage standard sont d'une classe de qualité 8.8.

Nous recommandons de ne pas utiliser une classe de qualité inférieure à 8.8 pour tous les composants d'assemblage standards.

Pour les pièces non standard, les pièces de remplacement doivent impérativement provenir de Norton CLIPPER.

La durée de vie des pièces d'usure varie en fonction de l'utilisation et de la maintenance de la machine ou de la pièce. Les pièces d'usure devront être entretenues et remplacées au besoin. Aucune garantie n'est appliquée aux pièces d'usure.

Les composants NA (Not Available) ne sont pas disponibles en pièce de rechange.

DEUTSCH

TYP :

S = Ersatzteile

W = Verschleißteile

NA = nicht verfügbare

Die definierten Ersatzteil-Set's beinhalten alle Ersatzteile wie Komponenten, Schrauben, Muttern etc.

Norm- bzw. Standardteile wie Schrauben, Muttern etc. können bei offiziellen Schrauben- sowie Komponentenhändler bezogen werden.

Alle Norm- bzw. Standardteile wie Schrauben, Muttern etc. entsprechen der Qualitäts- bzw. Festigungsklasse 8.8.

Wir empfehlen, keine Norm- bzw. Standardteile wie Schrauben, Muttern etc. unter der Qualitäts- bzw.

Festigungsklasse 8.8 einzusetzen.

Es dürfen nur geprüfte Norton CLIPPER-Ersatzteile eingesetzt werden.

Die Lebensdauer der Verschleißteile hängt von der Verwendung und Wartung der Maschine oder des Teils ab. Verschleißteile müssen gewartet und bei Bedarf ersetzt werden. Für Verschleißteile wird keine Garantie übernommen.

Ersatzteile sowie Komponenten mit dem Vermerk NA (NA=nicht verfügbar) sind nicht verfügbar.



Pages 4-6



Pages 7-10

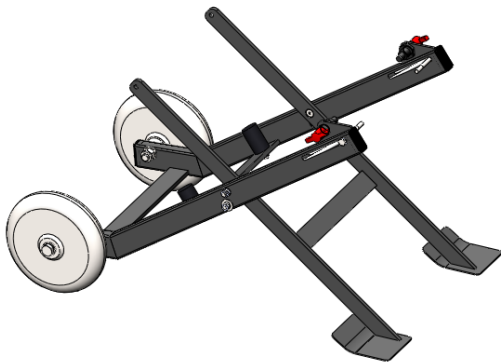

Pages 11-12

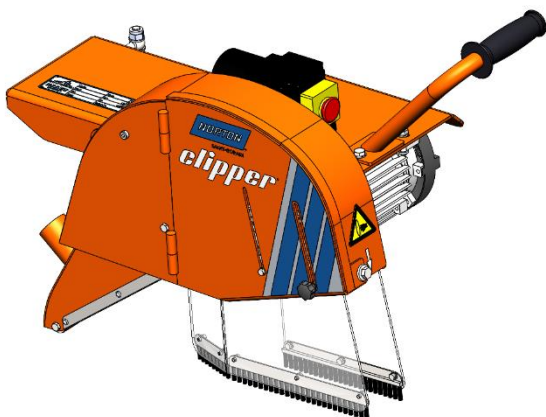

Pages 13-19

Main frame / Châssis principal / Gestell

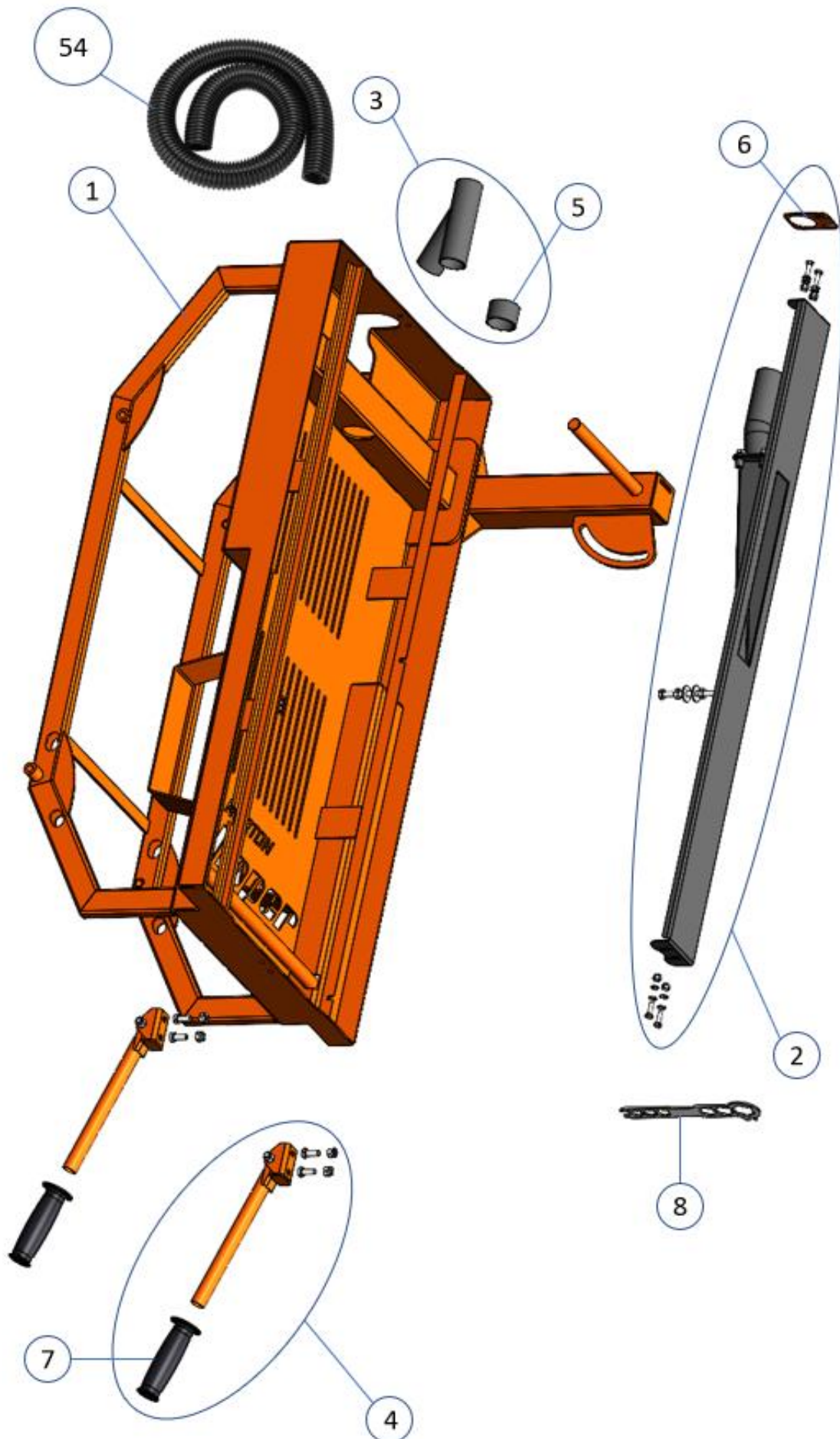

POS.	DESCRIPTION	DESCRIPTION	BESCHREIBUNG	QTY	REF	TYPE
1	Frame	Châssis	Gestell	1	310619991	S
2	Complete aspiration system	Système d'aspiration complet	Ausaugsystem, kompl.	1	310620002	S
	Aspiration groove	Rainure d'aspiration	Saugnut	1		
	Aspiration tube	Tube d'aspiration	Saugrohr	1		
	Tube support	Support de tube	Rohrhalterung	1		
	Screw DIN 933 - M6x20	Vis DIN 933 - M6x20	Schraube DIN 933 - M6x20	4		
	Screw DIN 933 - M8x16	Vis DIN 933 - M8x16	Schraube DIN 933 - M8x16	4		
	Screw DIN 933 - M8x110	Vis DIN 933 - M8x110	Schraube DIN 933 - M8x110	1		
	Washer DIN 125 - M6	Rondelle DIN 125 - M6	Scheibe DIN 125 - M6	8		
	Washer DIN 125 - M8	Rondelle DIN 125 - M8	Scheibe DIN 125 - M8	4		
	Washer DIN 127 - M8	Rondelle DIN 127 - M8	Scheibe DIN 127 - M8	4		
	Washer DIN 9021 - M8	Rondelle DIN 9021 - M8	Scheibe DIN 9021 - M8	2		
	Nut ISO 4032 - M8	Écrou ISO 4032 - M8	Mutter ISO 4032 - M8	2		
	Nut ISO 7040 - M6	Écrou ISO 7040 - M6	Mutter ISO 7040 - M6	4		
3	Complete double vacuum	Aspiration double complet	Doppelabsaugung, kompl.	1	310620003	S
	Double vacuum	Aspiration double	Doppelabsaugung	1		
	Connector	Connecteur	Verbinder	1		
4	Handle assy.	Poignée complète	Griff, kompl.	1	310620004	S
	Handle	Poignée	Griff	1		
	Fixation support	Support de fixation	Halterung	1		
	Handle lock	Blocage de la poignée	Blockieren des Griffs	1		
	Rubber handle	Poignée en caoutchouc	Gummigriff	1		
	Screw DIN 933 - M8x45	Vis DIN 933 - M8x45	Schraube DIN 933 - M8x45	1		
	Screw DIN 933 - M8x20	Vis DIN 933 - M8x20	Schraube DIN 933 - M8x20	2		
	Nut ISO 7040 - M8	Écrou ISO 7040 - M8	Mutter ISO 7040 - M8	3		
5	Connector	Connecteur	Verbinder	1	310620005	S
6	Tube support	Support de tube	Rohrhalterung	1	310620036	S
7	Rubber handle	Poignée en caoutchouc	Gummigriff	1	310004190	S
8	Multiple wrench	Clé multiple	x-fache Maulschlüssel	1	510105548	S
54	Dust collector's pipe	Tuyau du récupérateur	Staubfängersrohr	1	310620077	S

Suction system / Système d'aspiration / Saugsystem

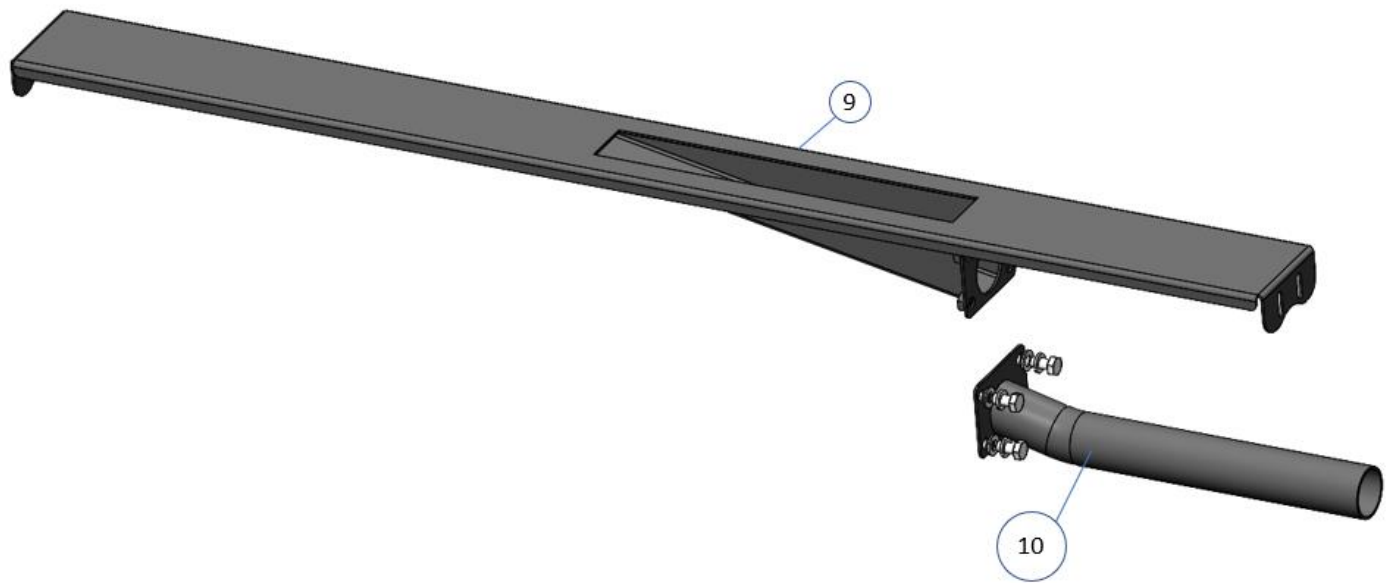

POS.	DESCRIPTION	DESCRIPTION	BESCHREIBUNG	QTY	REF	TYPE
9	Complete aspiration groove	Rainure d'aspiration complète	Saugnut, kompl.	1	310620037	S
	Aspiration groove	Rainure d'aspiration	Saugnut	1		
	Screw DIN 933 - M6x20	Vis DIN 933 - M6x20	Schraube DIN 933 - M6x20	4		
	Washer DIN 125 - M6	Rondelle DIN 125 - M6	Scheibe DIN 125 - M6	8		
	Nut ISO 7040 - M6	Écrou ISO 7040 - M6	Mutter ISO 7040 - M6	4		
10	Complete aspiration tube	Tube d'aspiration complet	Saugrohr, kompl.	1	310620038	S
	Aspiration tube	Tube d'aspiration	Saugrohr	1		
	Screw DIN 933 - M8x16	Vis DIN 933 - M8x16	Schraube DIN 933 - M8x16	4		
	Washer DIN 125 - M8	Rondelle DIN 125 - M8	Scheibe DIN 125 - M8	4		
	Washer DIN 127 - M8	Rondelle DIN 127 - M8	Scheibe DIN 127 - M8	4		

Table / Table / Tisch

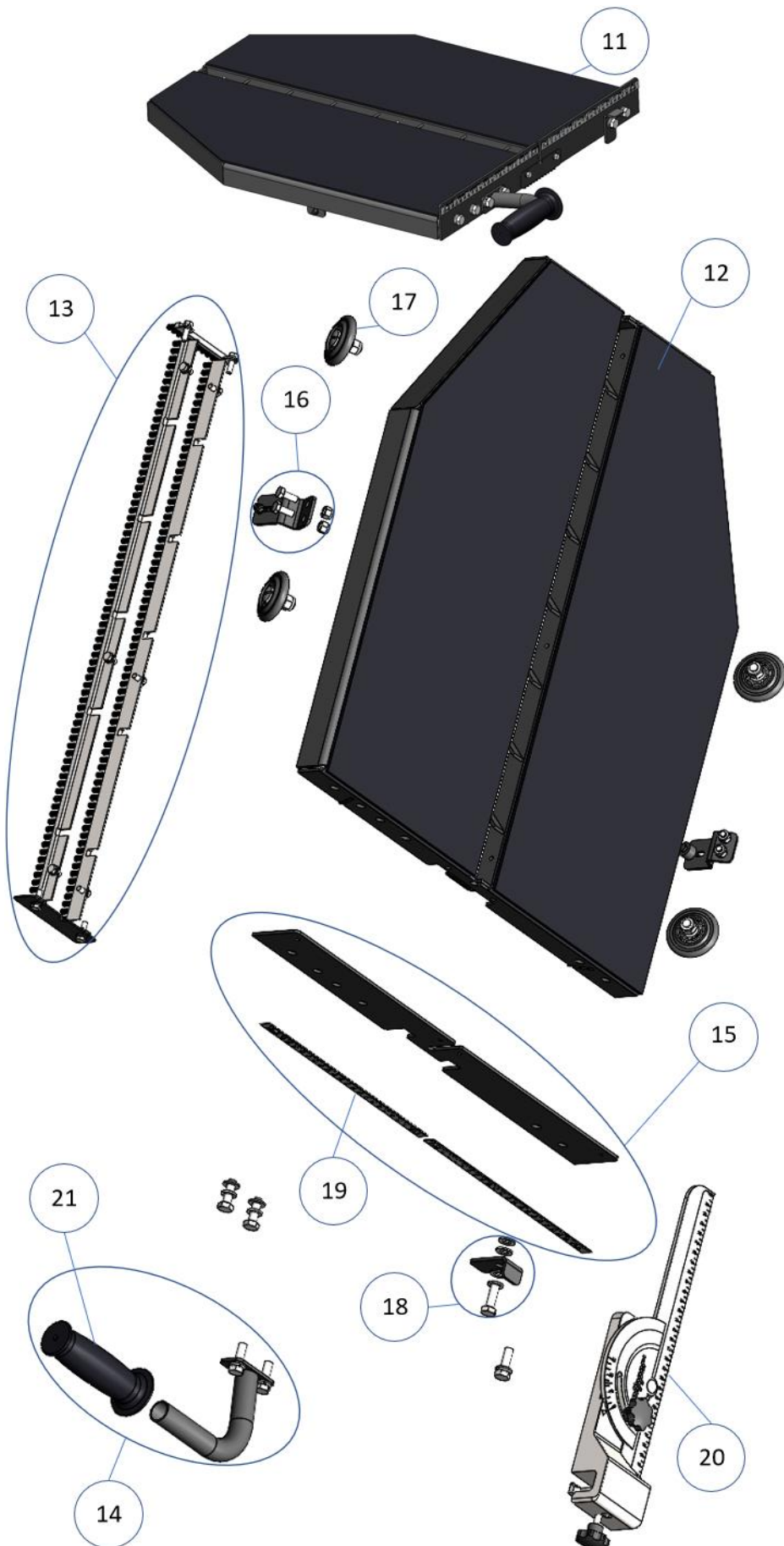

POS.	DESCRIPTION	DESCRIPTION	BESCHREIBUNG	QTY	REF	TYPE
11	Trolley assy	Chariot complet	Wagen, kompl.	1	310620039	S
12	Cutting table	Table de coupe	Schneidetisch	1	310620040	S
13	Table brush kit	Kit brosses de table	Tischbürste Satz	1	310620041	S
	Lateral Brush	Brosse latéral	Seitenbürste	2		
	Front/Back brush	Brosse avant/arrière	Vorne/Hinten Bürste	2		
	Brush cover	Couvercle de brosse	Bürstenabdeckung	1		
	Wedge	Cale	Halten	2		
	Screw DIN 933 - M5x16	Vis DIN 933 - M5x16	Schraube DIN 933 - M5x16	4		
	Screw DIN 933 - M5x6	Vis DIN 933 - M5x6	Schraube DIN 933 - M5x6	6		
	Washer DIN 125 - M5	Rondelle DIN 125 - M5	Scheibe DIN 125 - M5	10		
	Washer DIN 127 - M5	Rondelle DIN 127 - M5	Scheibe DIN 127 - M5	10		
14	Table handle kit	Kit poignée de table	Tischgriffe Satz	1	310620042	S
	Table handle	Poignée de table	Tischgriffe	1		
	Rubber handle	Poignée en caoutchouc	Gummigriff	1		
	Washer DIN 125 - M8	Rondelle DIN 125 - M8	Scheibe DIN 125 - M8	2		
	Washer DIN 127 - M8	Rondelle DIN 127 - M8	Scheibe DIN 127 - M8	2		
	Screw DIN 933 – M8x25	Vis DIN 933 – M8x25	Schraube DIN 933 – M8x25	2		
15	Material stop kit	Kit butée matériau	Materialanschlag Satz	1	310620043	S
	Material stop	Butée matériau	Materialanschlag	1		
	Ruler (set of 2)	Kit reglette (jeu de 2)	Regel (Satz von 2Stk)	1		
	Locking plate	Plaque de blocage	Blokierungsplatte	1		
	Washer DIN 125 - M8	Rondelle DIN 125 - M8	Scheibe DIN 125 - M8	5		
	Washer DIN 127 - M8	Rondelle DIN 127 - M8	Scheibe DIN 127 - M8	5		
	Screw DIN 933 – M8x25	Vis DIN 933 – M8x25	Schraube DIN 933 – M8x25	5		
	Rivet DIN 7337 A - 3.0 x 6.0	Rivet DIN 7337 A - 3.0 x 6.0	Niete DIN 7337 A - 3.0 x 6.0	4		
16	Retaining trolley kit	Kit anti-basculément	Aufrechterhaltungswagen Satz	1	310620044	S
	Retaining plate	Plaque d'anti-basculément	Aufrechterhaltungsplatte	1		
	Retaining roller	Rouleau anti bascule	Aufrechterhaltungsroller	1		
	Screws ISO 7380 - M4x20	Vis ISO 7380 - M4x20	Schraube ISO 7380 – M4x20	1		
	Washer DIN 125 - M4	Rondelle DIN 125 - M4	Scheibe DIN 125 - M4	1		
	Nut ISO 4035 - M4	Écrou ISO 4035 - M4	Mutter ISO 4035 - M4	1		
	Nut ISO 7040 - M4	Écrou ISO 7040 - M4	Mutter ISO 7040 - M4	1		
	Screw DIN 933 – M6x16	Vis DIN 933 - M6x16	Schraube DIN 933 – M6x16	2		
	Nut ISO 7040 - M6	Écrou ISO 7040 - M6	Mutter ISO 7040 - M6	2		
17	Wheels (set of 4)	Roulette (jeu de 4)	Rolle (Satz von 4Stk)	1	310004676	S
	Wheels	Roulettes	Lenkrolle	4		
	Screw – M8x25	Vis – M8x25	Schraube – M8x25	4		
	Washer DIN 125 - Ø8,4	Rondelle DIN 125 - Ø8,4	Scheibe DIN 125 - Ø8,4	16		
	Washer DIN 127 - M8	Rondelle DIN 127 - M8	Scheibe DIN 127 - M8	4		
	Nut DIN 934 - M8	Écrou DIN 934 - M8	Mutter DIN 934 - M8	4		

Table / Table / Tisch



POS.	DESCRIPTION	DESCRIPTION	BESCHREIBUNG	QTY	REF	TYPE
18	Locking trolley kit	Kit blocage chariot	Blockierungswagen Satz	1	310620045	S
	Locking plate	Plaque de blocage	Blokierungsplatte	1		
	Washer DIN 125 - M8	Rondelle DIN 125 - M8	Scheibe DIN 125 - M8	3		
	Washer DIN 127 - M8	Rondelle DIN 127 - M8	Scheibe DIN 127 - M8	1		
	Screw DIN 933 – M8x25	Vis DIN 933 – M8x25	Schraube DIN 933 – M8x25	1		
19	Ruler (set of 2)	Kit réglette (jeu de 2)	Regel (Satz von 2Stk)	1	310620046	S
	Ruler	Réglette	Regel	2		
	Rivet DIN 7337 A - 3.0 x 6.0	Rivet DIN 7337 A - 3.0 x 6.0	Niete DIN 7337 A - 3.0 x 6.0	4		
20	Angular guide a cut	Guide de coupe angulaire	Winkelfräserführung	1	310064856	S
	Angular guide a cut	Guide de coupe angulaire	Winkelfräserführung	1		
	screw DIN 316 – M6x20	Vis DIN 316 – M6x20	Schraube DIN 316 – M6x20	2		
	RETAINING RINGS DIN 6799	ANNEAUX ELASTIQUES DIN 6799	Elastischen Ringe DIN 6799	1		
	Locking pins	Goupille de blocage	Sperrbolzen	1		
	Screw DIN 965 – M5x30	Vis DIN 965 – M5x30	Schraube DIN 965 – M5x30	1		
	Washer DIN 125 – Ø6,4	Rondelle DIN 125 – Ø6,4	Scheibe DIN 125 – Ø6,4	1		
21	Rubber handle	Poignée en caoutchouc	Gummigriff	1	310004190	S

Stand / Stand / Stand

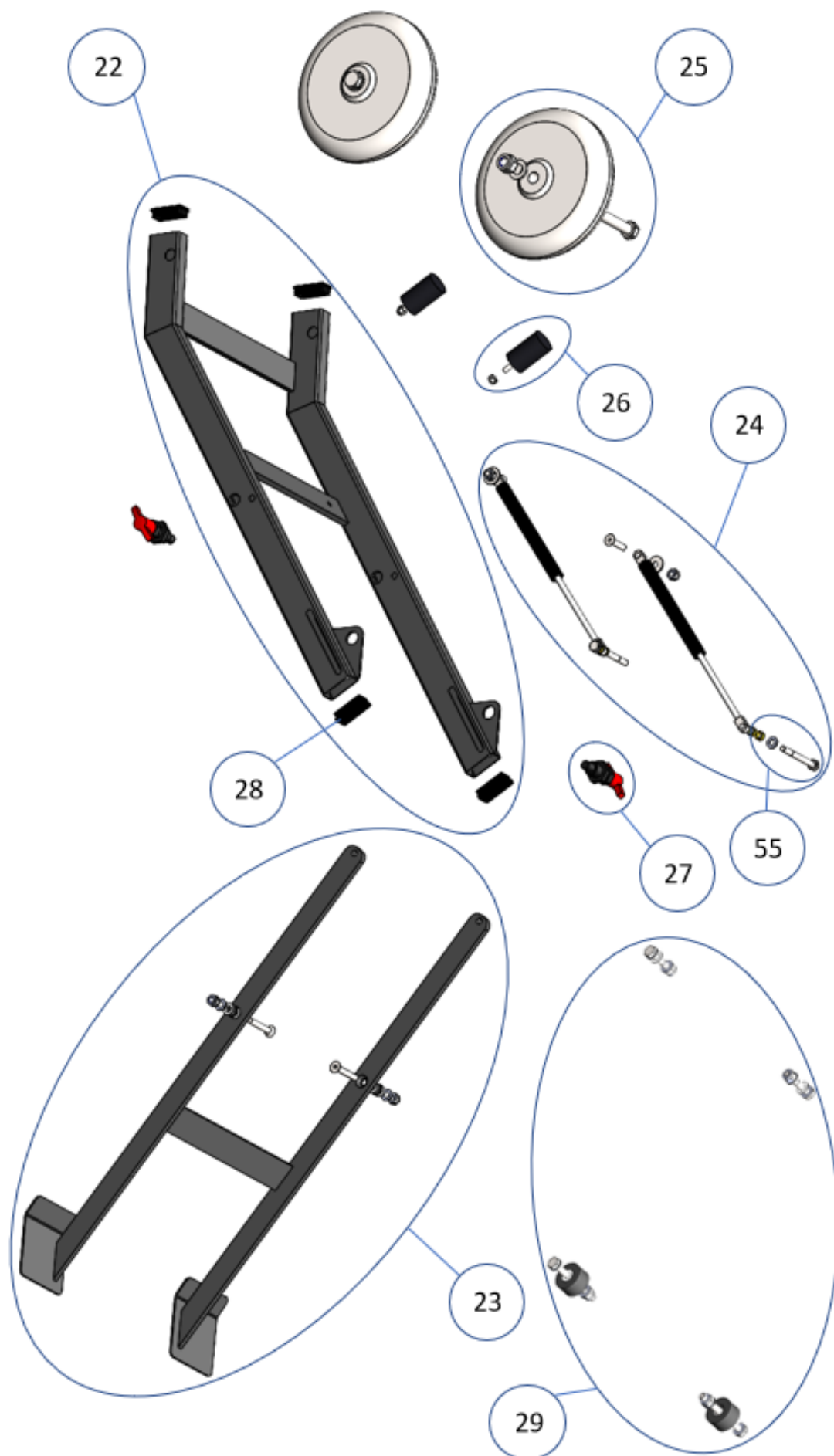

POS.	DESCRIPTION	DESCRIPTION	BESCHREIBUNG	QTY	REF	TYPE
22	Foot tube kit	Kit pieds tubulaires	Röhrenfuß Satz	1	310620047	S
	Foot tube	Pieds tubulaires soudés	Röhrenfuß	1		
	Tube cap	Bouchon tube	Röhrendeckel	4		
23	Flat foot kit	Kit pieds plats	Plattfuß Satz	1	310620048	S
	Flat foot	Pieds plats soudés	Plattfuß	1		
	Screw DIN 7991 - M10x65	Vis DIN 7991 - M10x65	Schraube DIN 7991 - M10x65	2		
	Plastic washer M10	Rondelle en plastique M10	Plastikscheibe M10	4		
	Little spacer	Entretoise	Kleiner Abstandshalter	2		
	Washer DIN 125 - M10	Rondelle DIN 125 - M10	Scheibe DIN 125 - M10	2		
	Nut ISO 7040 - M10	Écrou ISO 7040 - M10	Mutter ISO 7040 - M10	2		
24	Gas spring kit (set of 2)	Kit vérin à gaz (jeu de 2)	Gasdruckfeder Satz (Satz von 2Stk)	1	310620049	S
	Gas spring	Vérin à gaz	Gasdruckfeder	2		
	Gas spring spacer	Entretoise vérin à gaz	Abstandshalter Gasdruckfeder	4		
	Screw DIN 931 - M10x95	Vis DIN 931 - M10x95	Schraube DIN 931 - M10x95	2		
	Screw DIN 7991 - M10x45	Vis DIN 7991 - M10x45	Schraube DIN 7991 - M10x45	2		
	Washer DIN 125 - M10	Rondelle DIN 125 - M10	Scheibe DIN 125 - M10	2		
	Washer DIN 9021 - M10	Rondelle DIN 9021 - M10	Scheibe DIN 9021 - M10	2		
	Nut ISO 7040 - M10	Écrou ISO 7040 - M10	Mutter ISO 7040 - M10	2		
25	Wheel kit	Kit roue	Transportrad	1	310620050	S
	Wheel	Roue	Räder	1		
	Plastic washer M18	Rondelle en plastique M18	Plastikscheibe M18	1		
	Washer DIN 125 - M18	Rondelle DIN 125 - M18	Scheibe DIN 125 - M18	2		
	Nut ISO 7040 - M18	Écrou ISO 7040 - M18	Mutter ISO 7040 - M18	1		
	Screw DIN 933 - M18x140	Vis DIN 933 - M18x140	Schraube DIN 933 - M18x140	1		
26	Rubber stop	Butée en caoutchouc	Gummistopper	1	310620051	S
	Rubber stop	Butée en caoutchouc	Gummistopper	1		
	Nut ISO 7040 - M8	Écrou ISO 7040 - M8	Mutter ISO 7040 - M8	1		
27	Indexable pin	Goupille indexable	Indexstifte	1	310620052	S
28	Tube cap	Bouchon tube	Röhrendeckel	1	310620053	S
29	Stand to chassis mounting kit	Kit fixation stand au châssis	Befestigung des Standes am Gestell Satz	1	310620054	S
	Screw DIN 931 - M10x95	Vis DIN 931 - M10x95	Schraube DIN 931 - M10x95	2		
	Screw DIN 933 - M10x55	Vis DIN 933 - M10x55	Schraube DIN 933 - M10x55	2		
	Cylindrical rubber stop	Butée cylindrique en caoutchouc	Zylindrischer Gummistopper	2		
	Plastic washer	Rondelle en plastique	Plastikscheibe	4		
	Washer DIN 125 - M10	Rondelle DIN 125 - M10	Scheibe DIN 125 - M10	8		
	Nut ISO 7040 - M10	Écrou ISO 7040 - M10	Mutter ISO 7040 - M10	4		
55	Gas spring spacer kit	Kit entretoise vérin à gaz	Abstandshalter Gasdruckfeder Satz	1	310620900	W
	Screw DIN 931 - M10x95	Vis DIN 931 - M10x95	Schraube DIN 931 - M10x95	2		
	Brass gas spring spacer	Entretoise vérin à gaz en laiton	Abstandshalter Gasdruckfeder	4		

Cutting head / Tête de coupe / Schüsselkopf

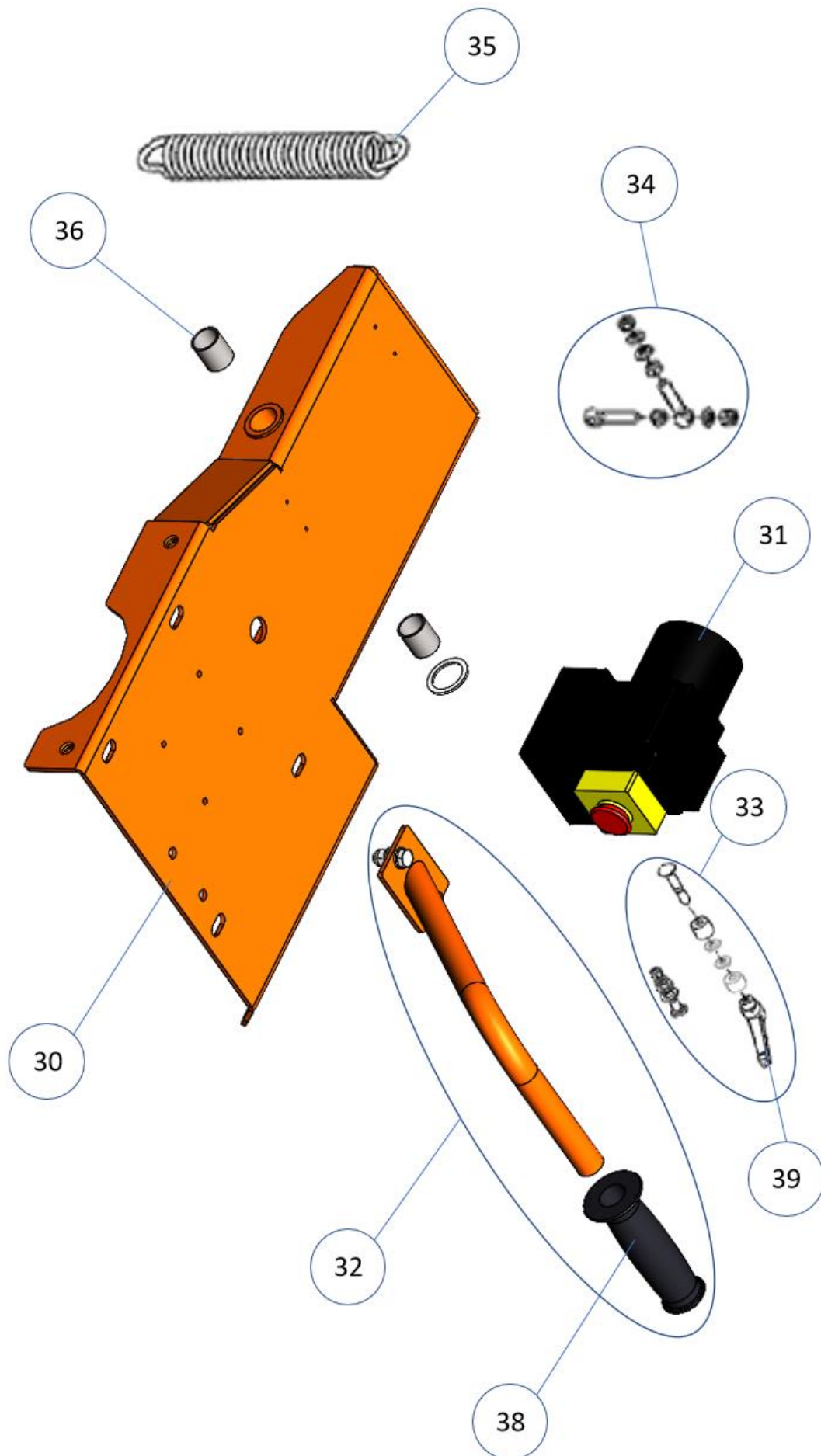

POS.	DESCRIPTION	DESCRIPTION	BESCHREIBUNG	QTY	REF	TYPE
30	Cutting head	Tête de coupe	Schüsselkopf	1	310620055	S
31	Switch assy. 230V	Interrupteur complet 230V	230V Schalter, kompl.	1	510103106	S
	Switch	Interrupteur	Schalter	1		
	Screw DIN 912 – M5X55	Vis DIN 912 – M5X55	Schraube DIN 912 – M5X55	2		
	Screw DIN 7981 F - ST 4,8x20	Vis DIN 7981 F - ST 4,8x20	Schraube DIN 7981 F - ST 4,8x20	2		
32	Handle kit	Kit poignée	Griff Satz	1	310620056	S
	Welded handle	Poignée soudé	Geschweißter Griff	1		
	Rubber handle	Poignée en caoutchouc	Gummigriff	1		
	Screw DIN 933 - M8x25	Vis DIN 933 - M8x25	Schraube DIN 933 - M8x25	2		
	Washer DIN 125 - M8	Rondelle DIN 125 - M8	Scheibe DIN 125 - M8	4		
	Nut ISO 7040 - M8	Écrou ISO 7040 - M8	Mutter ISO 7040 - M8	2		
33	Locking head	Vérouillage de tête	Kopfarretierungshebel	1	510109122	S
	Screw DIN 603 – M12X35	Vis DIN 603 – M12X35	Schraube DIN 603 – M12X35	1		
	Washer DIN 125 - A17	Rondelle DIN 125 - A17	Scheibe DIN 125 - A17	1		
	Washer DIN 125 - A13	Rondelle DIN125 - A13	Scheibe DIN 125 - A13	2		
	Washer DIN 127 - A12	Rondelle DIN127 - A12	Scheibe DIN 125 - A12	1		
	Nut DIN985 - M12	Écrou DIN985 - M12	Mutter DIN985 - M12	1		
	Screw DIN603 - M12x90	Vis DIN603 - M12x90	Schraube DIN603 - M12x90	1		
	Adjustable handle M12	Poignée ajustable M12	Einstellbarem Griff M12	1		
	Spacer 30x13x22	Entretoise 30x13x22	Distanzring 30x13x22	1		
	Spacer 30x13x27	Entretoise 30x13x27	Distanzring 30x13x27	1		
34	Adjustment of tension of the spring	Réglage tension ressort	Federspannungregelung	1	510109121	S
	Screw DIN 444 - M10X60	Vis DIN 444 - M10X60	Schraube DIN 444 - M10X60	2		
	Nut DIN985 - M10	Écrou DIN985 - M10	Mutter DIN985 - M10	2		
	Washer DIN125 - A10,5	Rondelle DIN125 - A10,5	Scheibe DIN125 - A10,5	4		
	Nut DIN934 - M10	Écrou DIN934 - M10	Mutter DIN934 - M10	1		
35	Spring	Ressort	Rückstellfeder	1	310620057	S
36	Self lubricating ring (set of 2)	Bagues d'articulation (jeu de 2)	Gelenkringe (Satz von 2 Stk)	1	310005129	S
38	Rubber handle	Poignée en caoutchouc	Gummigriff	1	310004190	S
39	Adjustable handle M12	Poignée ajustable M12	Einstellbarem Griff M12	1	510105561	S

Motor / Moteur / Motor

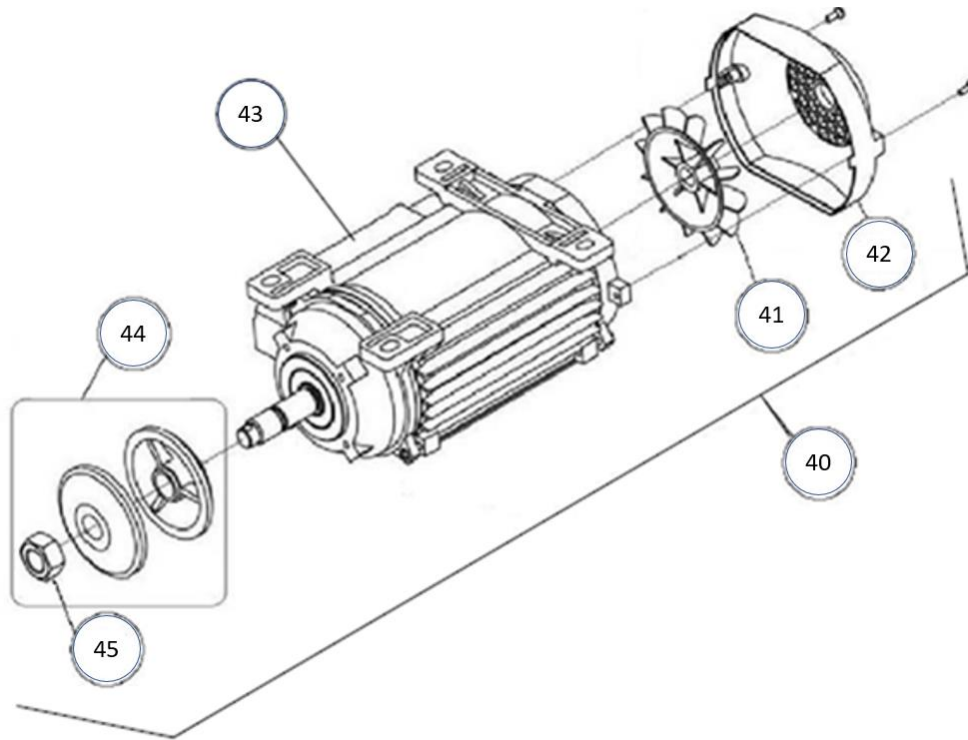

POS.	DESCRIPTION	DESCRIPTION	BESCHREIBUNG	QTY	REF	TYPE
40	Electric motor 230V compl.	Moteur électrique 230V complet	230V Elektromotor Satz kompl.	1	310047701	S
	Electric motor 230V	Moteur électrique 230V	Elektromotor 230V	1		
	Screw DIN 933 - M8X25	Vis DIN 933 - M8X30	Schraube DIN 933 - M8X25	4		
	Washer DIN 125 - Ø8,4	Rondelle DIN 125 - Ø8,4	Scheibe DIN 125 - Ø8,4	8		
	Washer DIN 127 - Ø8,4	Rondelle DIN 127 - Ø8,4	Scheibe DIN 127 - Ø8,4	4		
	Nut DIN 985 - M8	Écrou DIN 985 - M8	Mutter DIN 985 - M8	4		
	Cover of ventilator	Capot de ventilateur	Schutzkasten von ventilator	1		
	Screw DIN 7985H – M5X30	Vis DIN 7985H – M5X30	Vis DIN 7985H – M5X30	2		
	AirScrew	Hélices de ventilateur	Propeller	1		
	Flanges + Nut	Flasques + Écrou	Flansche + Mutter	1		
	Blade fixing Nut M18 LH	Écrou de serrage M18 LH	M18 Spannmutter LH	1		
41	AirScrew MOTOR ABLE	Hélice ventilateur MOTEUR ABLE	Propeller MOTOR ABLE	1	510121619	S
42	Cover of ventilator MOTOR ABLE	Capot ventilateur MOTEUR ABLE	Schutzkasten von ventilator MOTOR ABLE	1	310411378	S
	Cover of ventilator	Capot de ventilateur	Schutzkasten von ventilator	1		
	Screw DIN 7985H – M5X30	Vis DIN 7985H – M5X30	Vis DIN 7985H – M5X30	2		
43	Capacitor 40µF	Condensateur 40µF	Kondensator 40µF	1	310370870	S
44	Flanges + Nut MOTOR ABLE	Flasques + Écrou MOTEUR ABLE	Flansche + Mutter MOTOR ABLE	1	510121144	S
45	Blade fixing Nut M20 LH MOTOR ABLE	Écrou de serrage M20 LH MOTEUR ABLE	SchneidwellenMutter MOTOR ABLE	1	310048259	S

Blade guard / Carter de disque / Plattegehäuse

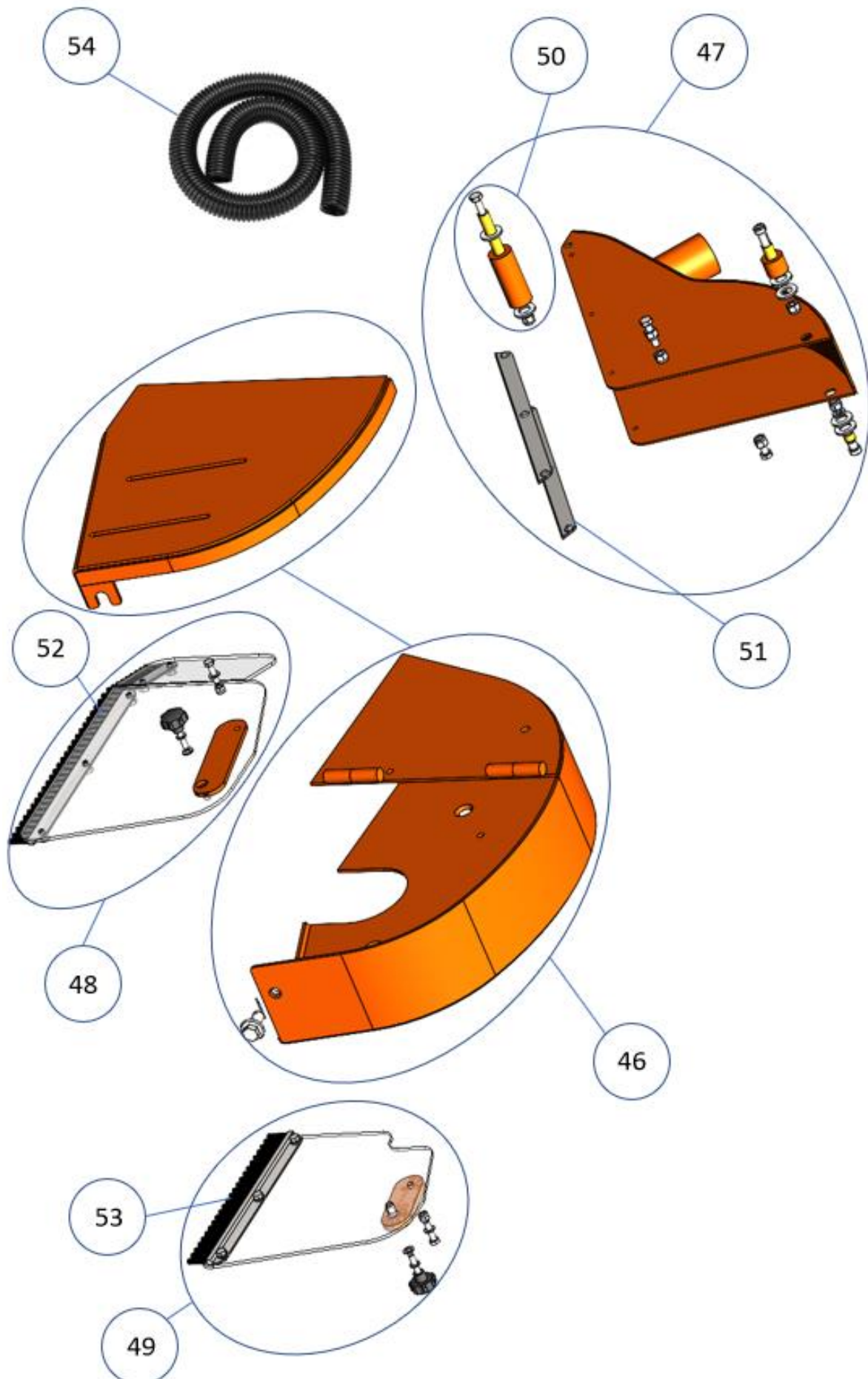

POS.	DESCRIPTION	DESCRIPTION	BESCHREIBUNG	QTY	REF	TYPE
46	Complete blade guard	Carter de disque complet	Gehäuse, kompl.	1	310620059	S
	Fixe blade guard	Carter de disque fixe	Festes Gehäuse	1		
	Mobile blade guard	Carter de disque mobile	Mobiles Gehäuse	1		
	Flange screw DIN 6921 - M10x20	Vis à embase DIN 6921 - M10x20	Ansatzschraube DIN 6921 - M10x20	1		
	Splint pin DIN 94 1,6x16	Goupille fendue DIN 94 1,6x16	Splinte DIN 94 1,6x16	1		
47	Dust collector kit	Kit récupérateur de poussière	Staubfänger Satz	1	310620060	S
	Dust collector	Récupérateur de poussière	Staubfänger	1		
	Little guide axis	Petit axe de guidage	Kleiner Führungsschse	2		
	Big guide axis	Grand axe de guidage	Große Führungsschse	1		
	Spacer	Entretoise	Distanzring	1		
	Shoulder screw M6x8	Vis épaulée M6x8	Schulterchraube M6x8	2		
	Shoulder screw M6x25	Vis épaulée M6x25	Schulterchraube M6x25	1		
	Washer DIN 125 - M6	Rondelle DIN 125 - M6	Scheibe DIN 125 - M6	2		
	Screw DIN 933 - M6x16	Vis DIN 933 - M6x16	Schraube DIN 933 - M6x16	1		
	Screw DIN 933 - M6x25	Vis DIN 933 - M6x25	Schraube DIN 933 - M6x25	1		
	Sliding guard	Protecteur de glissement	Rutschschutz	2		
	Rivet DIN 7337 A - 4.0 x 6.0	Rivet DIN 7337 A - 4.0 x 6.0	Niete DIN 7337 A - 4.0 x 6.0	6		
	Roller	Rouleau	Rolle	1		
	Axis	Axe	Achse	1		
	Screw DIN 931 - M6x75	Vis DIN 931 - M6x75	Schraube DIN 931 - M6x75	1		
	Plastic washer	Rondelle en plastique	Plastikscheibe	6		
	Nut ISO 7040 - M6	Écrou ISO 7040 - M6	Mutter ISO 7040 - M6	6		
48	Dust deflector kit Nut side	Kit déflecteur de poussière Côté écrou	Staubabweiser Satz Mutterseite	1	310620061	S
	Dust deflector	Déflecteur de poussière	Staubabweiser	1		
	Deflector spacer	Entretoise du déflecteur	Deflektor-Distanzstück	1		
	Big brush	Grande brosse	Großbürste	1		
	Little brush	Petite brosse	Kleine Bürste	1		
	Screw DIN 933 - M5x35	Vis DIN 933 - M5x35	Schraube DIN 933 - M5x35	1		
	Screw DIN 7991 - M4x10	Vis DIN 7991 - M4x10	Schraube DIN 7991 - M4x10	5		
	Nut ISO 7040 - M4	Écrou ISO 7040 - M4	Mutter ISO 7040 - M4	5		
	Knurled screw - M5x35	Vis moleté - M5x35	Rändelschraube - M5x35	1		
	Washer DIN 125 - M5	Rondelle DIN 125 - M5	Scheibe DIN 125 - M5	2		
	Washer DIN 127 - M5	Rondelle DIN 127 - M5	Scheibe DIN 127 - M5	1		
	Nut ISO 7040 - M5	Écrou ISO 7040 - M5	Mutter ISO 7040 - M5	1		
	Rivet nut M5	Rivet fileté M5	Nietenmutter M5	1		

Blade guard / Carter de disque / Plattegehäuse

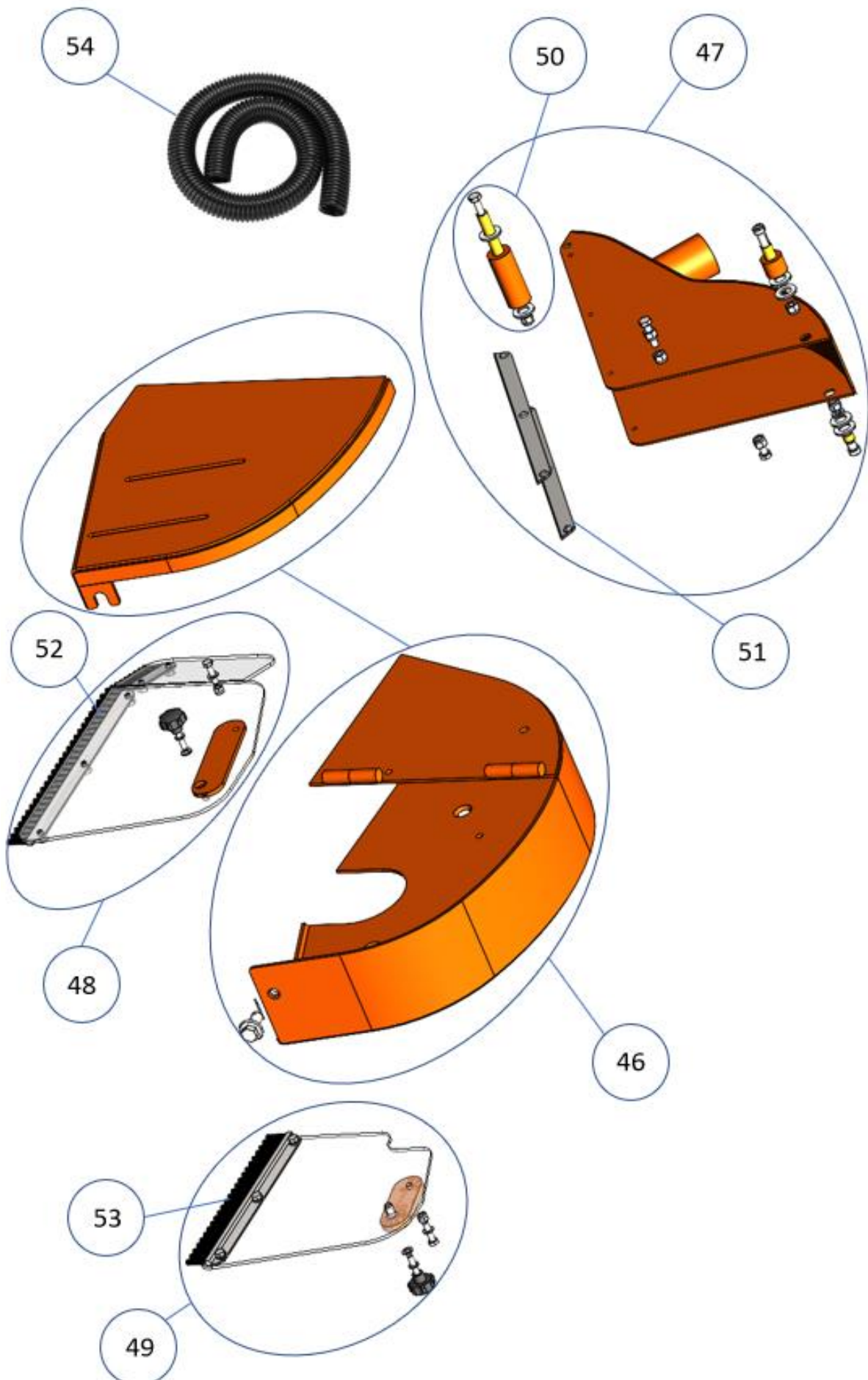

POS.	DESCRIPTION	DESCRIPTION	BESCHREIBUNG	QTY	REF	TYPE
49	Dust deflector kit Motor side	Kit déflecteur de poussière Côté moteur	Staubabweiser Satz Motorseite	1	310620062	S
	Dust deflector	Déflecteur de poussière	Staubabweiser	1		
	Deflector spacer	Entretoise du déflecteur	Deflektor-Distanzstück	1		
	Big brush	Grande brosse	Großbürste	1		
	Little brush	Petite brosse	Kleine Bürste	1		
	Screw DIN 933 - M5x20	Vis DIN 933 - M5x20	Schraube DIN 933 - M5x20	1		
	Screw DIN 7991 - M4x10	Vis DIN 7991 - M4x10	Schraube DIN 7991 - M4x10	3		
	Nut ISO 7040 - M4	Écrou ISO 7040 - M4	Mutter ISO 7040 - M4	3		
	Knurled screw - M5x20	Vis moleté - M5x20	Rändelschraube - M5x20	1		
	Washer DIN 125 - M5	Rondelle DIN 125 - M5	Scheibe DIN 125 - M5	2		
	Washer DIN 127 - M5	Rondelle DIN 127 - M5	Scheibe DIN 127 - M5	1		
	Nut ISO 7040 - M5	Écrou ISO 7040 - M5	Mutter ISO 7040 - M5	1		
	Rivet nut M5	Rivet fileté M5	Nietenmutter M5	1		
50	Roller set	Kit rouleau	Rolle Satz	1	310620063	
	Roller	Rouleau	Rolle	1		
	Axis	Axe	Achse	1		
	Plastic washer	Rondelle en plastique	Plastikscheibe	2		
	Screw DIN 931 - M6x75	Vis DIN 931 - M6x75	Schraube DIN 931 - M6x75	1		
	Nut ISO 7040 - M6	Écrou ISO 7040 - M6	Mutter ISO 7040 - M6	1		
51	Sliding guard kit	Kit protecteur de glissement	Rutschschutz Satz	1	310620064	
	Sliding guard	Protecteur de glissement	Rutschschutz	2		
	Rivet DIN 7337 A - 4.0 x 6.0	Rivet DIN 7337 A - 4.0 x 6.0	Niete DIN 7337 A - 4.0 x 6.0	6		
52	Brush kit (nut side)	Kit brosse (côté écrou)	Bürste Satz (Mutterseite)	1	310620065	S
	Big brush	Grande brosse	Großbürste	1		
	Little brush	Petite brosse	Kleine Bürste	1		
	Screw DIN 7991 - M4x10	Vis DIN 7991 - M4x10	Schraube DIN 7991 - M4x10	5		
	Nut ISO 7040 - M4	Écrou ISO 7040 - M4	Mutter ISO 7040 - M4	5		
53	Brush kit (motor side)	Kit brosse (côté moteur)	Bürste Satz (Motorseite)	1	310620076	S
	Brush	Brosse	Bürste	1		
	Screw DIN 7991 - M4x10	Vis DIN 7991 - M4x10	Schraube DIN 7991 - M4x10	3		
	Nut ISO 7040 - M4	Écrou ISO 7040 - M4	Mutter ISO 7040 - M4	3		
54	Dust collector's pipe	Tuyau du récupérateur	Staubfängersrohr	1	310620077	S

Stickers / Autocollants / Aufkleber

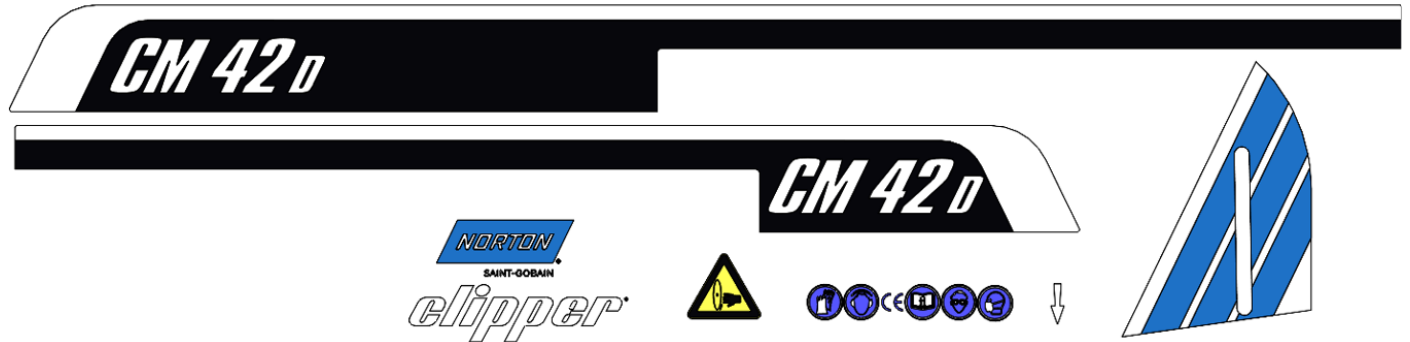

POS.	DESCRIPTION	DESCRIPTION	BESCHREIBUNG	QTY	REF	TYPE
-	Sticker kit	Kit d'autocollants	Aufkleber Satz	1	310620078	S
	White arrow	Flèche blanche	Weißer Pfeil	1		
	4 pictograms	4 pictogrammes	4 Piktogramme	1		
	Wear a dust mask	Portez un masque anti-poussière	Tragen Sie eine Staubmaske	1		
	Right side	Flanc droit	Rechte Flanke	1		
	Left side	Flanc gauche	linke Flanke	1		
	Norton Clipper Logo Blade guard	Norton Clipper carter de disque	Norton Clipper Scheibegehäuse	1		
	Norton Clipper Logo Blade guard back	Norton Clipper carter de disque arrière	Norton Clipper Hinterplattegehäuse	1		
	Logo 3 bands	Logo 3 bandes	Logo 3 Bänder	1		
	Risk of hand cut	Risque de coupure main	Gefahr von Schnittverletzungen	1		
-	Carton box	Boite en carton	Kartonbox	1	310620079	S

SAINT-GOBAIN ABRASIVES
INDUSTRIEWEG 21
9420 ERPE-MERE
BELGIUM
TEL: +32(0) 2 267 21 00

SAINT-GOBAIN CONSTRUCTION PRODUCTS
CZ A.S
DIVIZE ABRASIVES
SMRČKOVA 2485/4
180 00 PRAHA 8
CZECH REPUBLIC
TEL: +420 255 719 326
FAX: +420 255 719 321

SAINT-GOBAIN ABRASIVES A/S
DYBENDALSVÆNGET 2,
DK-2630 TAASTRUP
DENMARK
TEL: +45 4675 5244

PO BOX 643706
FORTUNE TOWER OFFICE 2106
JLT BLOCK C
(NEXT TO METRO STATION)
JUMEIRA LAKE TOWER, DUBAI
UNITED ARAB EMIRATES
TEL: +971 4 431 5154
FAX: +971 4 431 5434

SAINT-GOBAIN ABRASIFS
RUE DE L'AMBASSADEUR - B.P.8
78 702 CONFLANS CEDEX
FRANCE
TEL: +33 (0)1 34 90 40 00
FAX: +33 (0)1 39 19 89 56

SAINT-GOBAIN ABRASIVES GMBH
BIRKENSTRASSE 45-49
D-50389 WESSELING
GERMANY
TEL: +49 (0) 2236 703-0
FAX: +49 (0) 2236 703-730

SAINT-GOBAIN ABRASIVES KFT.
1225 BUDAPEST
BÁNYALÉG U. 60/B.
HUNGARY
TEL: +36 1 371 22 50
FAX: +36 1 371 22 55

SAINT-GOBAIN ABRASIVI S.P.A
VIA PER CESANO BOSCONI 4
I-20094 CORSICO MILANO
ITALY
TEL: +39 02 44 851
FAX: +39 02 44 78 266

SAINT-GOBAIN ABRASIVES S.A.
190 RUE J.F. KENNEDY
L-4930 BASCHARAGE
GRAND DUCHE DE LUXEMBOURG
TEL: +352 50 401 1
FAX: +331 83 717 792
NO. VERT (FRANCE): 0800 906 903

SAINT-GOBAIN ABRASIFS, S.A.
2 ALLÉE DES FIGUIERS
AIN SEBAË - CASABLANCA
MOROCCO
TEL: +212 5 22 66 57 31
FAX: +212 5 22 35 09 65

SAINT-GOBAIN ABRASIVES BV
GROENLOSEWEG 28
7151 HW EIBERGEN
P.O. BOX 10
7150 AA EIBERGEN
THE NETHERLANDS
TEL: +31 545 466466
FAX: +31 545 474605

SAINT-GOBAIN ABRASIVES AS
KARIHAUGVEIEN, 89
0186 OSLO
NORWAY
TEL: +47 63 87 06 00
FAX: +47 63 87 06 01

SAINT-GOBAIN HPM POLSKA SP. Z O.O.
UL. NORTON 1, 62-600 KOŁO
62-600 KOŁO
POLAND
TEL: +48 63 26 17 100
FAX: +48 63 27 20 401

SAINT-GOBAIN ABRASIVOS, L. DA
ZONA INDUSTRIAL DA MAIA
I-SECTOR VIII, NO. 122
APARTADO 6050
4476 - 908 MAIA
PORTUGAL
TEL: +351 229 437 940
FAX: +351 229 437 949

SAINT-GOBAIN GLASS
BUSINESS UNIT ABRASIVI
PUNCT DE LUCRU : LOC.VETIS, JUD.
SATU MARE 447355
STR. CAREIULUI 11
PARC INDUSTRIAL RENOVATIO
ROMANIA
TEL: +40 261 839 709
FAX: +40 261 839 710

SG HPM RUS
58, F. ENGELS STR.
STROENIE 2
105082 MOSCOW
RUSSIA
TEL: +74 955 408 355
FAX: +74 959 373 224

SAINT-GOBAIN
ABRASIVES (PTY) LTD
2 MONTEER ROAD
ISANDO 1600
P.O. BOX 67
SOUTH AFRICA
TEL: +27 11 961 2000
FAX: +27 11 961 2184/5

SAINT-GOBAIN ABRASIVOS, S.A.
CTRA. DE GUIPÚZCOA, KM. 7,5
E-31195 BERRIOPLANO (NAVARRA)
SPAIN
TEL: +34 948 306 000
FAX: +34 948 306 042

SAINT GOBAIN ABRASIVES AB
GÅRDSFOGDEVÄGEN 18A
168 66 BROMMA • SVERIGE
SWEDEN
TEL: +46 8 580 881 00
FAX: +46 8 580 881 30

SAINT-GOBAIN INOVATIF MALZEMELER VE
ASINDIRICI SAN. TIC. AS.
ALTAYÇEŞME MAH. ÇAMLI SOK. NO:21 ESAS
OFISPARK KAT:9 34843
MALTEPE, İSTANBUL • TURKEY
TEL: 0090-216-217 12 50
FAX: 0090-216-442 40 74

SAINT-GOBAIN ABRASIVES LTD.
UNICORN HOUSE UNIT 1, AMISON CLOSE
REDHILL BUSINESS PARK
STAFFORD ST161WB
UNITED KINGDOM
TEL: +44 1785 279 553
FAX: +44 1785 213 487



Saint-Gobain Abrasifs
190 Rue J.F. Kennedy
L-4930 Bascharage
Grand Duche de Luxembourg
Tel: +352 50 4011
Fax: +331 83 717 792
no. vert (France) 0800 906 903

www.nortonabrasives.com/fr-fr