

C99E

OPERATING INSTRUCTIONS



clipper®



Declaration of conformity

The undersigned manufacturer:

**SAINT-GOBAIN ABRASIVES S.A.
190, BD J.F. KENNEDY
L- 4930 BASCHARAGE**

Declares that this product:

Floor saw: **CS 99 E 75.3 400V**

Code: **70184613946**

is in conformity with the following Directives:

- **European Machinery Directive 2006/42/EC**
- **"LOW VOLTAGE" 2006/95/EC**
- **Electromagnetic Compatibility Directive 2004/108/EC**

and European standard:

- **EN 13862 Floor cutting-off machines - Safety**

A handwritten signature in black ink, appearing to read "Olivier Plenert", with a long horizontal flourish extending to the right.

Olivier Plenert
Machine Design Manager

C99E

OPERATING INSTRUCTIONS

1	<u>Basic Safety Instructions</u>	6
1.1	<i>Symbols</i>	6
1.2	<i>Machine plate</i>	7
1.3	<i>Safety instructions for particular operating phases</i>	7
2	<u>General description of the C99</u>	8
2.1	<i>Short description</i>	8
2.2	<i>Layout</i>	9
2.3	<i>Technical data</i>	10
3	<u>Assembly and commissioning</u>	10
3.1	<i>Operator's handle assembly</i>	10
3.2	<i>Tool assembly</i>	10
3.3	<i>Water cooling system</i>	11
3.4	<i>Electrical connections</i>	11
4	<u>Transport and Storing</u>	12
4.1	<i>Securing for transport</i>	12
4.2	<i>Transport procedure</i>	12
4.3	<i>Long period of inactivity</i>	12
5	<u>Operating the C99</u>	12
5.1	<i>Site of work</i>	12
5.2	<i>Cutting method</i>	12
6	<u>Maintenance and service</u>	13
7	<u>Faults: causes and cures</u>	15
7.1	<i>Fault-finding procedures</i>	15
7.2	<i>Trouble-shooting guide</i>	15
7.3	<i>Circuit diagram</i>	16
7.4	<i>Customer service</i>	16
8	<u>Appendix</u>	Error! Bookmark not defined.
8.1	<i>Spare parts list</i>	Error! Bookmark not defined.
8.2	<i>Exploded part drawings</i>	Error! Bookmark not defined.
9	<u>General sales conditions (do not apply for U.K.)</u>	Error! Bookmark not defined.

1 Basic Safety Instructions

The C99 is exclusively designed for the cutting of floors made of asphalt, green and cured concrete (reinforced or not) as well as of industrial cement.

Uses other than the manufacturer's instructions shall be considered as contravening the regulations. The manufacturer shall not be held responsible for any resulting damage. Any risk shall be borne entirely by the user. Observing the operating instructions and compliance with inspection and servicing requirements shall also be considered as included under use in accordance with the regulations.

1.1 Symbols

Important warnings and pieces of advice are indicated on the machine using symbols. The following symbols are used on the machine:

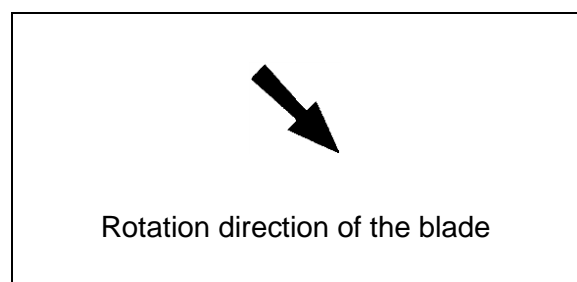
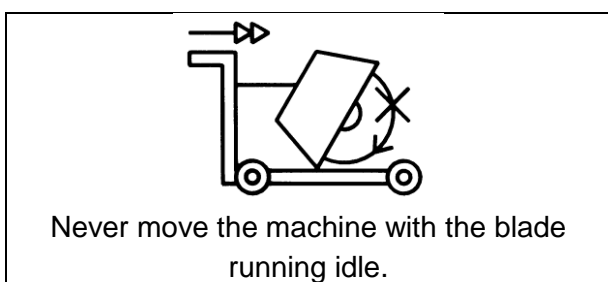
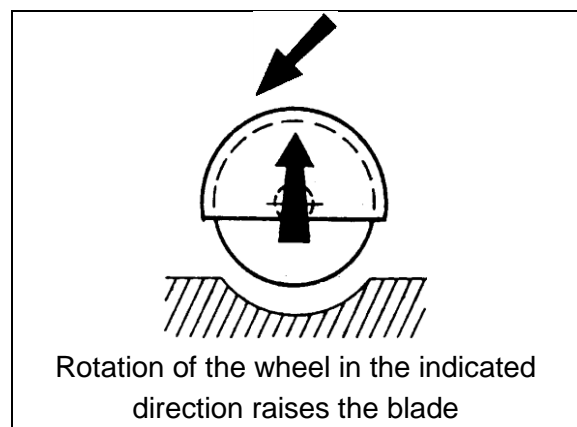
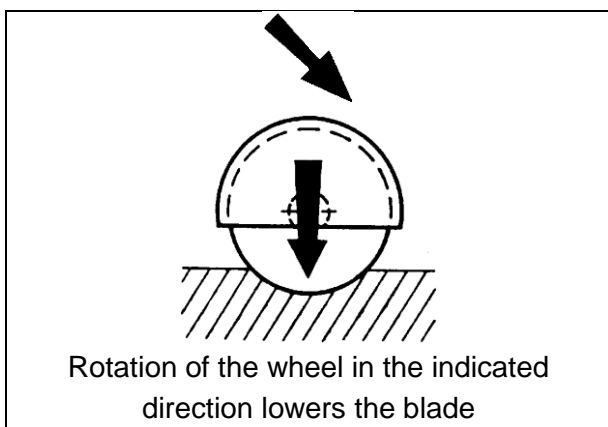
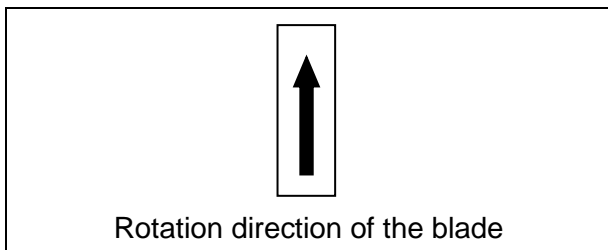
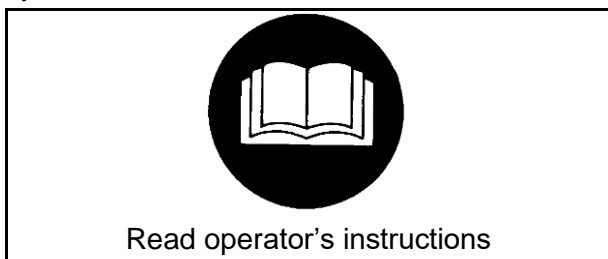

1.2 Machine plate

Important data can be found on the following plate located on the machine:

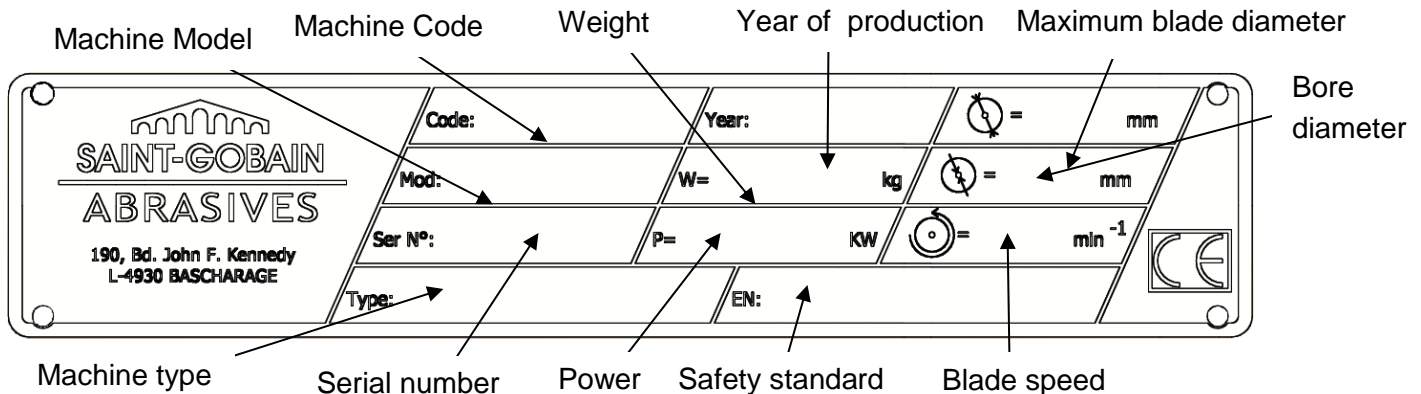

1.3 Safety instructions for particular operating phases

Before commencing work

- Before commencing work, make yourself familiar with the working environment at the place of use. The working environment includes: obstacles in the area of work and manoeuvre, the firmness of the floor, necessary protection at the site relating to public thoroughfares and the availability of help in the event of accidents.
- Check for correct mounting of the blade regularly.
- Immediately remove damaged or badly worn blades, as they endanger the operator whilst rotating.
- Always cut with the blade guard in position.
- Only fit NORTON diamond blades to the machine! The use of other tools can damage the machine!
- Attention is drawn to the use of BS2092 safety goggles in conformity with specified Processes No.8 of the Protection of Eyes Regulation 1974, Regulation 2(2) Part 1.
- For security reasons, never leave the machine unattended, untied or unlocked.

While the engine is running

- Do not move the machine whilst the blade is running idle.
- Do not run the machine without the security guards in place.
- Apply cooling water continuously whilst cutting and in good time!

Electrical powered machine

- Always turn off the machine and separate it from the main source of electricity before any work on the machine is done.
- Make all electrical connections securely to eliminate contact of live wires with spray water or dampness
- When the machine is used with water, it is IMPERATIVE that you earth the machine properly.
- In the event of the machine breaking down or stopping for no apparent reason, switch off the main electricity supply. Only a qualified electrician is allowed to investigate the trouble and remedy the fault.
- You can lock the ON-OFF-switch using a padlock.



2 General description of the C99

Any modification, which could lead to a change in the original characteristics of the machine, may be done only by Saint-Gobain Abrasives S.A. who shall confirm that the machine is still in conformity with the safety regulations. Saint-Gobain Abrasives S.A. keeps the right of making technical or design modification without prior notification.

2.1 Short description

The **Floor Saw C99** you have chosen, is used for small repair works in concrete and asphalt, for cutting induction loops and installing cables as well as for cutting expansion joints. It can be used for either wet or dry cutting operations.

Being of small construction, it can be transported in a car or van, the handle can be removed, reversed or retracted.

All component parts on the **C99** are assembled to a high quality standard, ensuring long life, reliability and a minimum of maintenance.

Special types of blades are available for asphalt, green concrete, cured concrete (reinforced or not) as well as for industrial cement flooring.

2.2 Layout

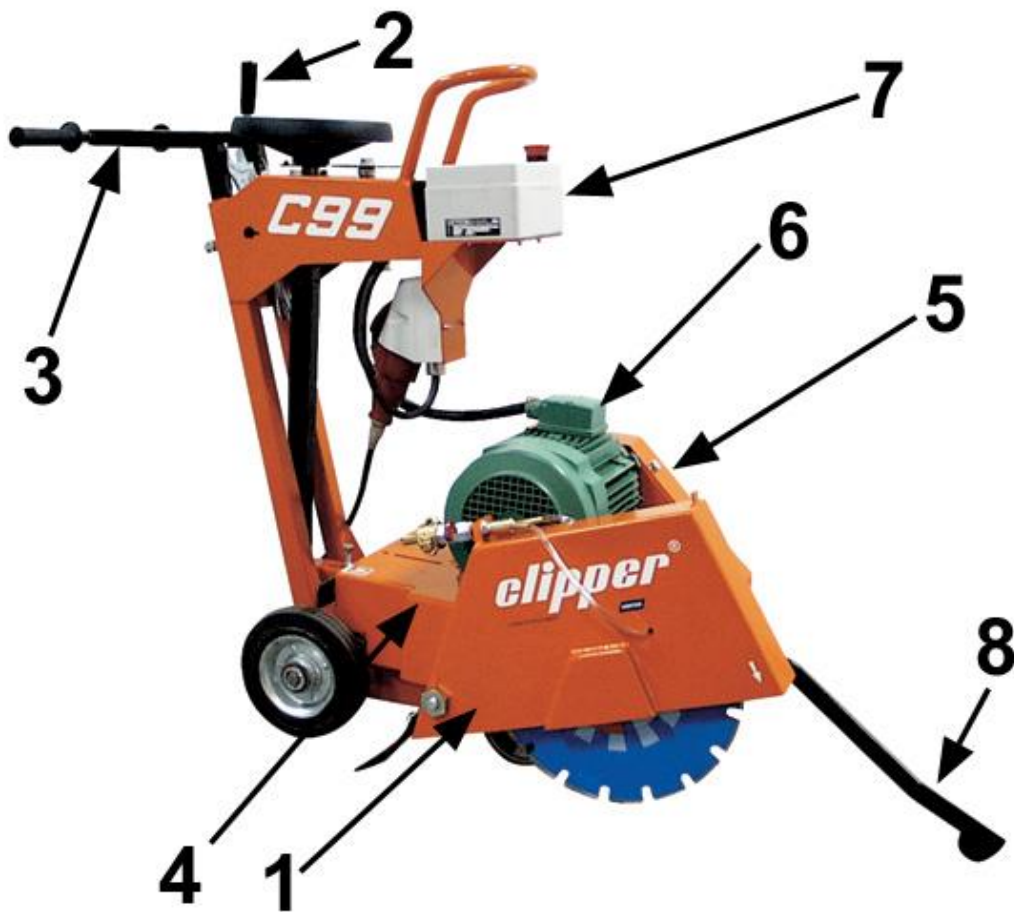

Made of jig welded open profile steel, the **C99** is stable but at the same time, easily transportable.

The one-piece blade guard (1) fully protects the operator and his working environment. It is firmly fixed to the main frame but can be opened by rotation to change blades. A water tank tap and two water nozzles located on the blade guard ensuring adequate flow of water to both sides of the cutting blade. The blade guard must be connected to the water network in order to use the machine with water.

A manually operated hand wheel mechanism (2) enables graduated depth setting. Turning the hand wheel clockwise or anti-clockwise will lower or raise the cutting blade. A depth gauge allows the operator to control precisely the depth of cut.

The handle (3) is detachable or can be reversed for easy transportation. The height is adjustable.

The pivoting frame (4), hinged on the rear axle, is supporting the engine, the blade shaft assembly, and the protecting guards. Four heavy-duty belts drive the blade.

The precisely manufactured blade shaft is fitted into two heavy-duty self-aligning pillow block bearings, including grease nipples. A four-belt taper lock pulley is fitted on one end. The shaft is reduced to 25,4mm at the other end, allowing an inner flange complete with dowel pinholes to be fixed.

The steel belt guard (5) is a sealed two piece unit. The backing plate is bolted to the mainframe of the machine and locking nuts are welded to it. The outer guard, covering the four drive belts and taper lock pulleys, is held in place by four locking bolts.

A spacer flange, 20mm in thickness and an outer flange, both with dowel pinholes, are provided. They are held with a 36mm locking nut.

The electric motor (6) with 5,5kW is connected to a delta-star switch (7). An emergency shut down switch is located on the left side of the machine near the levers. This allows an immediate stop of the machine in case of danger.

The pointer (8) allows the operator to make precise cut easily.

2.3 Technical data

Motor	3-phases electric motor with 5,5kW, 400V and No Volt Release switch
Motor protection	IP54
Max. blade diameter	450 mm
Bore	25,4 mm
Max. cutting depth mm	165 mm
Flange diameter	108 mm
Blade shaft speed	2850 min ⁻¹
Driving belts	4
Machine dimensions (length x width x height)	1160 x 512 x 990 mm in cutting configuration
Weight	105 kg
Max. operating weight	120 kg
Sound pressure level	80 dB (A) (ISO EN 11201)
Sound energy level	94 dB (A) (ISO EN 3744)

3 Assembly and commissioning

Before beginning the work with the C99, you have to assemble some parts.

3.1 Operator's handle assembly

Secure the operator's handle in a comfortable user position by using the locking nut.

3.2 Tool assembly

Only use NORTON blades with the C99.

A blade with a maximum diameter of 450 mm can be fitted. All tools used must be selected with regard to their maximum permitted cutting speed for the machine's maximum permitted rotation speed.

Before mounting a new blade into the machine, switch off the machine and isolate it from the main source of electricity.

To mount a new blade, follow these steps:

- Turn the wheel until the cutting head is in the raised position.
- Loosen the screw maintaining the guard and turn the blade guard open.

- Loosen the hexagonal nut on the blade shaft, which holds the removable outer flange.
- Remove the outer flange.
- Clean the flanges and blade shaft and inspect for wear.
- Mount the blade on the shaft ensuring that direction of rotation is correct. Wrong direction of rotation blunts the blade quickly.
- Replace outer blade flange.
- Tighten hexagonal nut with spanner supplied for this purpose.
- Close the blade guard.

The blade bore must correspond exactly to the blade shaft. Cracked or damaged bore is dangerous for the operator and for the machine.

3.3 Water cooling system

Open water-tap at blade guard (note that handle on water-tap should be in line with water-flow). Ensure that water is flowing freely in the circuit and delivered adequately to both sides of the blade, as insufficient water supply may result in premature failure of the diamond blade. In case of frost, empty the water cooling system.

3.4 Electrical connections

Electrical connections

Check that,

- the voltage/phase supply corresponds to the information indicated on the motor plate.
- Available power supply must have ground connection in conformity with safety regulations.
- The connecting cables should have at least a 2.5mm²-section per phase.

Switch on the machine

Put the ON-OFF-Switch on ON. Then put the Star-Triangle-Switch on Y. Wait until the blade reaches its maximum rotational speed, then turn the Star-Triangle-switch on Δ.

Direction of rotation

The direction of rotation is indicated on the blade guard. If the direction of rotation does not correspond to the direction shown by the arrow, then reverse the motor polarity by turning the phase inverter inside the male plug with a screwdriver.

Emergency Stop

To restart the machine after an emergency stop, turn the Star-Triangle-Switch on "0". Then turn the ON-OFF-Switch on ON.

4 Transport and Storing

Take the following measures in order to transport and store the C99 securely.

4.1 *Securing for transport*

Before transporting the machine:

- Remove the blade.
- Lower the handle in its fixing tube and secure it using the locking nut.
- Raise the guide-a-cut in its upright position.
- Raise the cutting head to its highest position using the handwheel.

4.2 *Transport procedure*

The machine can be moved on a flat surface using its wheels. Use the metal hook located over the switch to move the machine with a crane.

4.3 *Long period of inactivity*

If the machine is not going to be used for a long period, please take the following measures:

- Completely clean the machine.
- Loosen the drive belts.
- Grease the threaded shaft.
- Empty the water system.

The storage site must be clean, dry and at a constant temperature.

5 Operating the C99

5.1 *Site of work*

Before you start working, please check the following points:

- Remove from the site anything, which might hinder the working procedure.
- Make sure the site is sufficiently well lit.
- Observe manufacturer's conditions for connecting to power supplies!
- Place electric cables in such a way that damage by the device is excluded!
- Make sure you have a continual adequate view of the working area so you can intervene in the working process at any time.
- Keep other staff out of the area, so you can work securely.

5.2 *Cutting method*

In this section, you can find instructions to make a straight cut at the desired depth.

5.2.1 Preparing your cut

Before starting the machine,

- Draw a line on the floor over the cutting length.
- Make sure you have mounted the correct blade as recommended by the manufacturer depending on the material to be worked, the working procedure (dry or wet cut) to be carried out, and the efficiency required.
- Make sure that the flanges securely hold the diamond blade.

- Make sure that the blade is not touching the floor before starting.
- Adjust the handle to a comfortable position.
- Roll the machine until the blade is over the line.
- Lower the guide-a-cut so it touches the line.

5.2.2 Cutting the floor

You can now start the engine.

To make your cut,

- Turn the depth hand wheel until the blade slightly touches the floor.
- Open water valve to control the amount of water required for the type of blade, using 15 to 25l/min for wet and 1-2l/min for dry cutting, dust control. Check for minimum water level regularly.
- To lower blade into the cut, turn hand wheel clockwise. Each turn of the hand wheel will raise or lower the blade by 10mm.
- Once the required depth of cut is reached, push the machine forward with steady and gentle pressure and follow the line with the pointer. The feed speed must be adjusted depending on the material being cut, and depth of cut.
- If the thermal protection trips, wait a few minutes to allow the motor to cool down before restarting the machine.
- At the finish of the cut, raise the blade out of the cut by turning the hand wheel anti-clockwise, shut-off the water and switch off the motor.

6 Maintenance and service

ATTENTION : to perform maintenance on the machine, always switch it off. Always wear a face mask and safety goggles while performing the maintenance of machine. To ensure a long-term quality from the cutting with the C99, please follow the maintenance plan below:

		Regular service period Perform at every indicated period →							
		After one hour of work	Begin of the day	During the changing of the tool	End of the day	Every week	After a fault	After a damage	
Whole machine	Visual control (general aspect, watertightness)								
	Clean								
Flange and blade fixing devices	Clean								
Motor cooling fans	Clean								
Belts tension	Control								
Water hoses and nozzles	Clean								
Depth screw	Grease								
Engine housing	Clean								
Reachable nuts and screws	Tighten up								

Maintenance of the motor

Always perform the maintenance of the motor with the machine isolated from the electrical supply.

Adjustment and replacement of the belts

After one hour of work, the belts heat and stretch. Therefore, you have to re-tension them.

To adjust the belts, firstly remove the belt guard by unscrewing the 4 nuts. Loose the 4 engine bolts and shift the engine by using the two screws on the front.

To replace the belts, move the engine completely to the front. Adjust the belts and retighten them by shifting the motor to the rear.

Always use a matched set of belts. Do not replace single belts.

Lubrication

The C99 uses life-lubricated bearings. Therefore, you don't need to lubricate them at all.

Grease the depth screw every day.

Cleaning of the machine

Your machine will last longer if you clean it thoroughly after each day of work.

7 Faults: causes and cures

7.1 Fault-finding procedures

Should any fault occur during the use of the machine, turn it off, and isolate it from the electrical supply. Any works dealing with the electrical system or supply of the machine can only be carried out by a qualified electrician.

7.2 Trouble-shooting guide

Trouble	Possible source	Resolution
Wrong direction of rotation	Wrong motor polarity	Invert polarity on male plug
Motor is not running	No electricity	Check the electrical supply (fuse for example)
	Connection cable section too small	Change connection cable
	Defective connection cable	Change connection cable
	Defective switch	CAUTION : can only be solved by qualified electrician
	Defective motor	Change motor or contact motor manufacturer
Motor stops during the cutting, but can be restarted after a short period	Cutting advance too quick	Cut slowly
	Blade is blunt or glazed	Sharpen the blade in calcareous stone
	Defective blade	Change blade
	Wrong blade corresponding to the application	Change blade

7.3 Circuit diagram

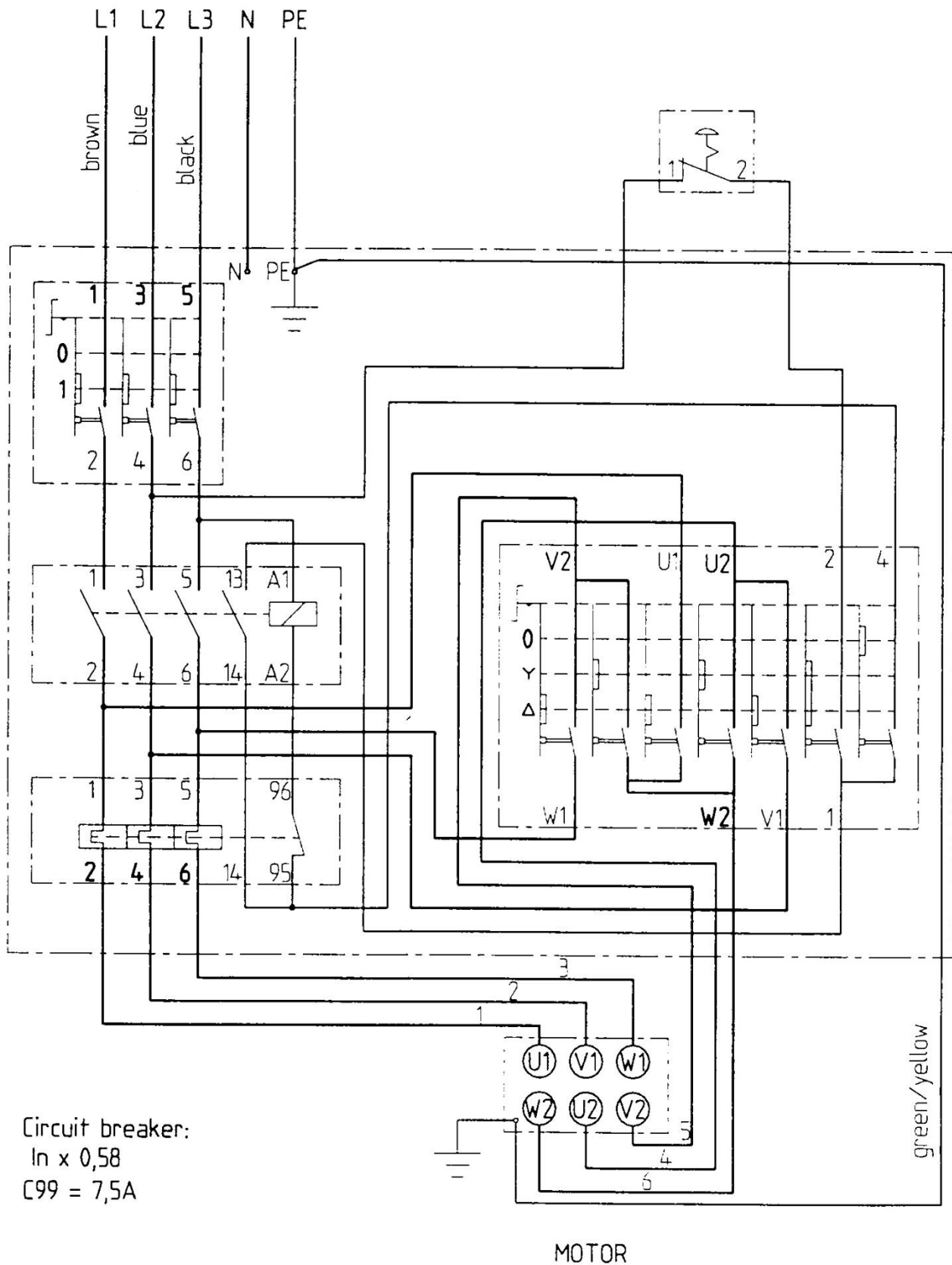

7.4 Customer service

When ordering spare parts, please mention:

- The serial number (a letter and 6 digits).

- The code of the part.
- The exact denomination.
- The number of parts required.
- The delivery address.
- Please indicate clearly the means of transportation required such as "express" or "by air". Without specific instructions, we will forward the parts through the means which seem appropriate to us and but which is not always the quickest way.

Clear instructions will avoid problems and faulty deliveries.

If not sure, please send us the defective part.

In the case of a warranty is claim, the part must always be returned for evaluation.

Spare parts for the engine can be ordered with the manufacturer of the engine or with their dealer, which is often quicker and cheaper.

This machine has been manufactured by Saint-Gobain Abrasives S.A.

190, rue J.F.Kennedy

L- 4930 BASCHARAGE

Grand-Duché de Luxembourg.

Tel. : 00352-50401-1

Fax : 00352- 50 16 33

<http://www.norton-diamond.com>

e-mail: sales.nlx@saint-gobain.com

Guarantee can be claimed and technical support obtained from your local distributor where machines, spare parts and consumables can be ordered as well:

Benelux and France:

From Saint-Gobain Abrasives
in the Grand-Duché de Luxembourg
Free telephone numbers:
Belgium : 0 800 18951
France: 0 800 90 69 03
Holland: 0 8000 22 02 70
e-mail: sales.nlx@saint-gobain.com

Germany

Saint-Gobain Diamond Products GmbH
Birkenweg 45-49,
D-50389 WESSELING
Tel : (02236) 8911 0
Fax : (02236) 8911 30
e-mail: sales.ngg@saint-gobain.com

Spain

Saint-Gobain Abrasivos S.A.
Ctra Guipuzcoa km7,5
31195 BERRIOPLANO (Navarra)
Tel: 0034 948 30 3000
Fax: 0034 948 30 6042
e-mail : Comercial.sga-apa@saint-gobain.com

Hungary

Saint-Gobain Abrasives KFT.
Budafoki u. 111
H-1117 BUDAPEST
Tel: ++36 1 371 2250
Fax: ++36 1 371 2255
e-mail: nortonbp@axelero.hu

Czech Republic

Norton Diamantove Nastroje Sro
Vinohradska 184
CS-13000 PRAHA 3
Tel: 0042 0267 13 20 21
Fax: 0042 0267 13 20 21
e-mail: norton.diamonds@komerce.cz

United Kingdom

Saint-Gobain Abrasives Ltd.
Unit 2, meridian West
Meridian Business Park
Leicester
LE19 1WX
Tel : 0116 2632 302
Fax : 0800 622 385
e-mail : nortondiamonduk@saint-gobain.com

Italy

Saint-Gobain Abrasivi S.p.A.
Via per Cesano Boscone, 4
I-20094 CORSICO-MILANO
Tel: 0039 02 44 851
Fax: 0039 0245 101238
e-mail: Norton.edilizia@saint-gobain.com

Austria

Saint-Gobain Abrasives GmbH
Telsenberggasse 37,
A-5020 SALZBURG
Tel: 0043 662 43 00 76 77
Fax: 0043 662 43 01 75
e-mail: office@sqa.net

Poland

Saint-Gobain Diamond Products Sp.zO.O.
AL. Krakowska 110/114
PL-00-971 WARSZAWA
Tel: 0048 22 868 29 36
Tel/Fax: 0048 22 868 29 27
e-mail: norton-diamond@wp.pl

www.construction.norton.eu

Saint-Gobain Abrasives

190, Bd. J. F. Kennedy
L-4930 BASCHARAGE
LUXEMBOURG

Tel: ++352 50401-1

Fax: ++352 501633

e-mail: sales.nlx@saint-gobain.com