

CK31

OPERATING INSTRUCTIONS



Declaration of conformity

The undersigned manufacturer:

SAINT - GOBAIN ABRASIVES S.A.
190, BD J.F. KENNEDY
L- 4930 BASCHARAGE

Declares that this product:

Floor saw: **CK 31 D KSA**

Code: **70184621027**

is in conformity with the following Directives:

- ***European Machinery Directive 2006/42/EC***
- ***Electromagnetic Compatibility Directive 2004/108/EC***

and European standard:

- ***EN 13862 – Floor cutting-off machines – Safety***



Olivier Plenert
Machine Design Manager

CK31

OPERATING INSTRUCTIONS

1	<u>Basic Safety Instructions</u>	6
1.1	<i>Symbols</i>	6
1.2	<i>Machine plate</i>	8
1.3	<i>Safety instructions for particular operating phases</i>	8
2	<u>General description of the CK31</u>	9
2.1	<i>Short description</i>	9
2.2	<i>Layout</i>	9
2.3	<i>Technical data</i>	11
2.4	<i>Vibration emission declaration</i>	12
3	<u>Assembly and commissioning</u>	13
3.1	<i>Tool assembly</i>	13
3.2	<i>Left or right cut</i>	13
3.3	<i>Water cooling system</i>	13
3.4	<i>Starting the machine</i>	14
4	<u>Transport and Storing</u>	15
4.1	<i>Securing for transport</i>	15
4.2	<i>Transport procedure</i>	15
4.3	<i>Long period of inactivity</i>	15
5	<u>Operating the CK31</u>	16
5.1	<i>Site of work</i>	16
5.2	<i>Cutting method</i>	16
6	<u>Maintenance and service</u>	18
6.1	<i>Maintenance of the machine</i>	18
6.2	<i>Maintenance of the engine</i>	20
7	<u>Faults: causes and cures</u>	25
7.1	<i>Fault-finding procedures</i>	25
7.2	<i>Trouble-shooting guide</i>	25
7.3	<i>Customer service</i>	26

1 Basic Safety Instructions

The CK31 is exclusively designed for the cutting of floors made of asphalt, green and cured concrete (reinforced or not) as well as of industrial cement.

Uses other than the manufacturer's instructions shall be considered as contravening the regulations. The manufacturer shall not be held responsible for any resulting damage. Any risk shall be borne entirely by the user. Observing the operating instructions and compliance with inspection and servicing requirements shall also be considered as included under use in accordance with the regulations.

1.1 Symbols

Important warnings and pieces of advice are indicated on the machine using symbols. The following symbols are used on the machine:

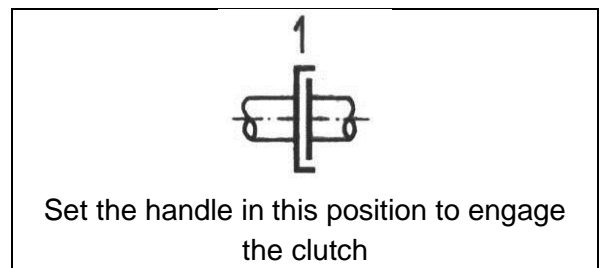
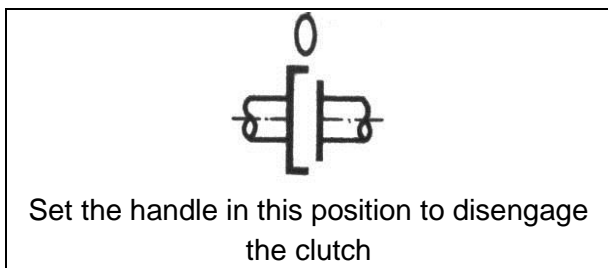
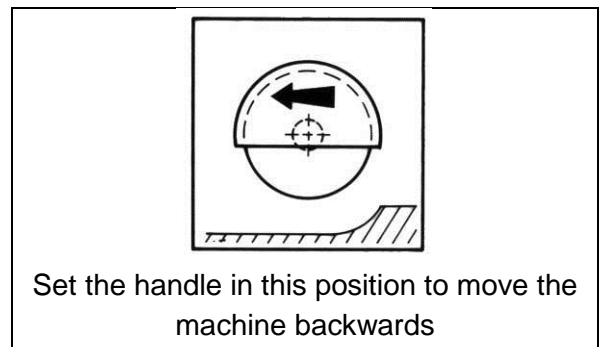
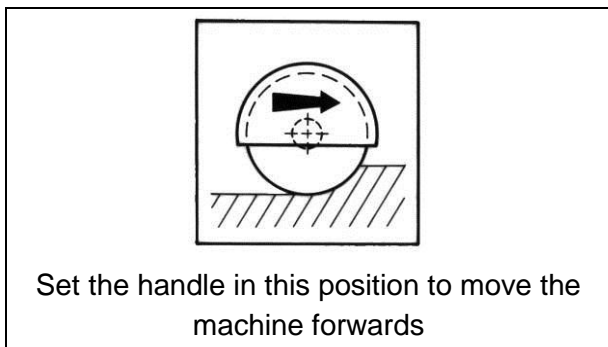
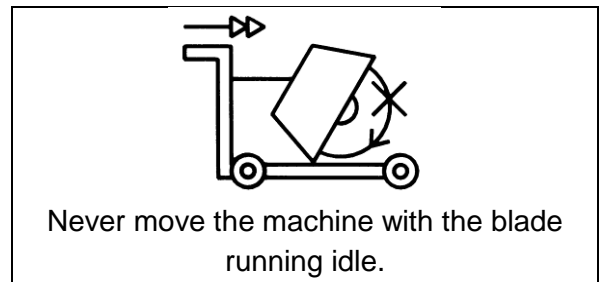
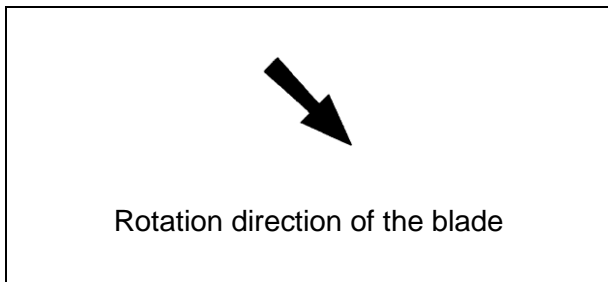
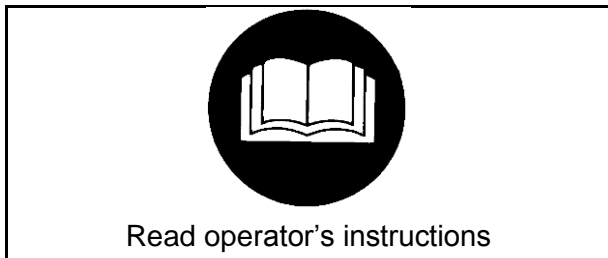

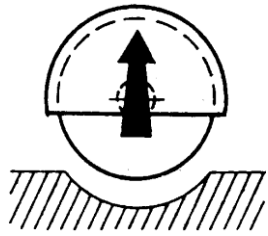

Press the button in this direction to raise the blade

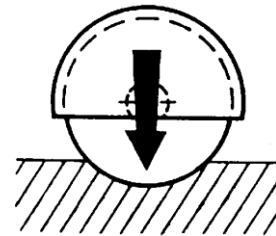

Press the button in this direction to lower the blade

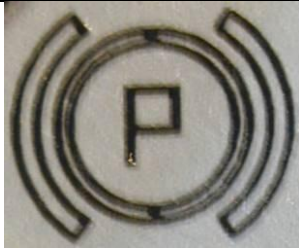

Parking brake on



Parking brake off



Emergency Stop



Danger: risk of cut

1.2 Machine plate

Important data can be found on the following plate located on the machine:

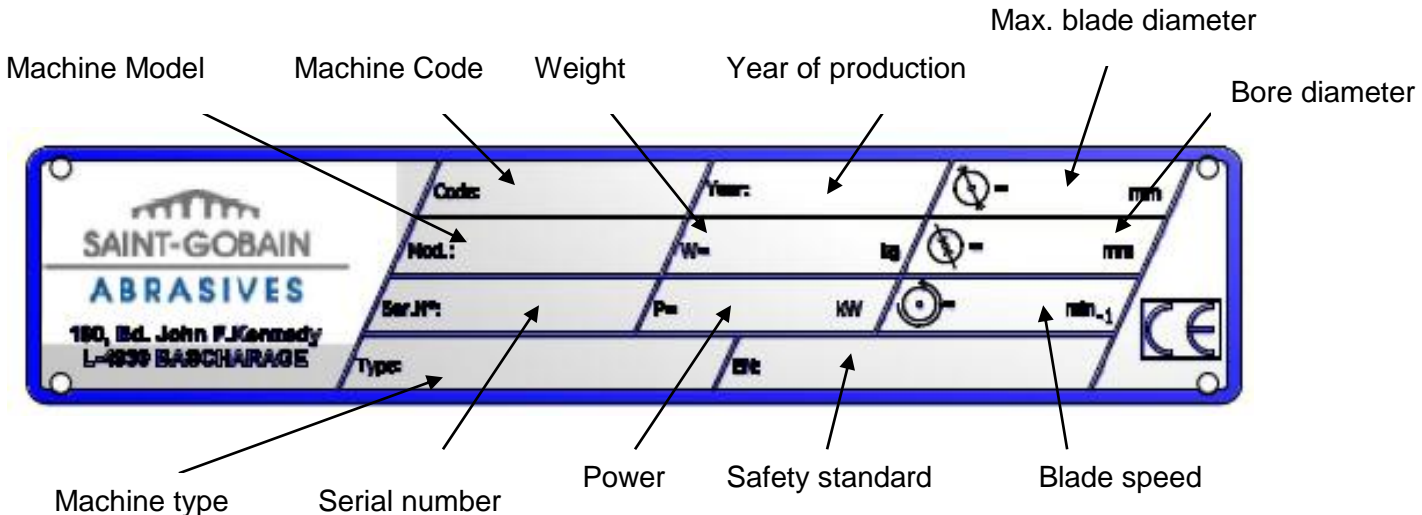

1.3 Safety instructions for particular operating phases

Before commencing work

- Before commencing work, make yourself familiar with the working environment at the place of use. The working environment includes: obstacles in the area of work and manoeuvre, the firmness of the floor, necessary protection at the site relating to public thoroughfares and the availability of help in the event of accidents.
- Check for correct mounting of the blade regularly.
- Immediately remove damaged or badly worn blades, as they endanger the operator whilst rotating.
- Always cut with the blade guard in position.
- Only fit NORTON diamond blades to the machine! The use of other tools can damage the machine!
- Attention is drawn to the use of BS2092 safety goggles in conformity with specified Processes No.8 of the Protection of Eyes Regulation 1974, Regulation 2(2) Part 1.
- For security reasons, never leave the machine unattended, untied or unlocked.

While the engine is running

- Do not move the machine whilst the blade is running idle.
- Do not run the machine without the security guards in place.
- Apply cooling water continuously whilst cutting and in good time!

Diesel powered machines:

- Always use the fuel advised.
- In confined areas, exhaust gases should be evacuated and the job site properly aerated.
- Diesel machines, which by their nature emit toxic exhaust gases, must not be used in places prohibited by the Health at Work Act 1974 or which are prohibited by Factory Inspectors or Safety Officers.
- Diesel is flammable. Before filling the tank, shut down the engine, extinguish all open flames and do not smoke. Take care that no diesel is spilled on any motor part. Always wipe up spilled fuel.

2 General description of the CK31

Any modification, which could lead to a change in the original characteristics of the machine, may be done only by Saint-Gobain Abrasives S.A. who shall confirm that the machine is still in conformity with the safety regulations. Saint-Gobain Abrasives S.A. keeps the right of making technical or design modification without prior notification.

2.1 Short description

The **Floor Saw CK31** you have chosen is used for repair works in concrete and asphalt on highways and runways, for trench sawing or cable loop cutting applications. It can be used for either wet or dry cutting operations. It can be easily transported.

All component parts on the **CK31** are assembled to a high quality standard, ensuring long life, reliability and a minimum of maintenance.

Special types of blades are available for asphalt, green concrete, cured concrete (reinforced or not) as well as for industrial cement flooring.

2.2 Layout

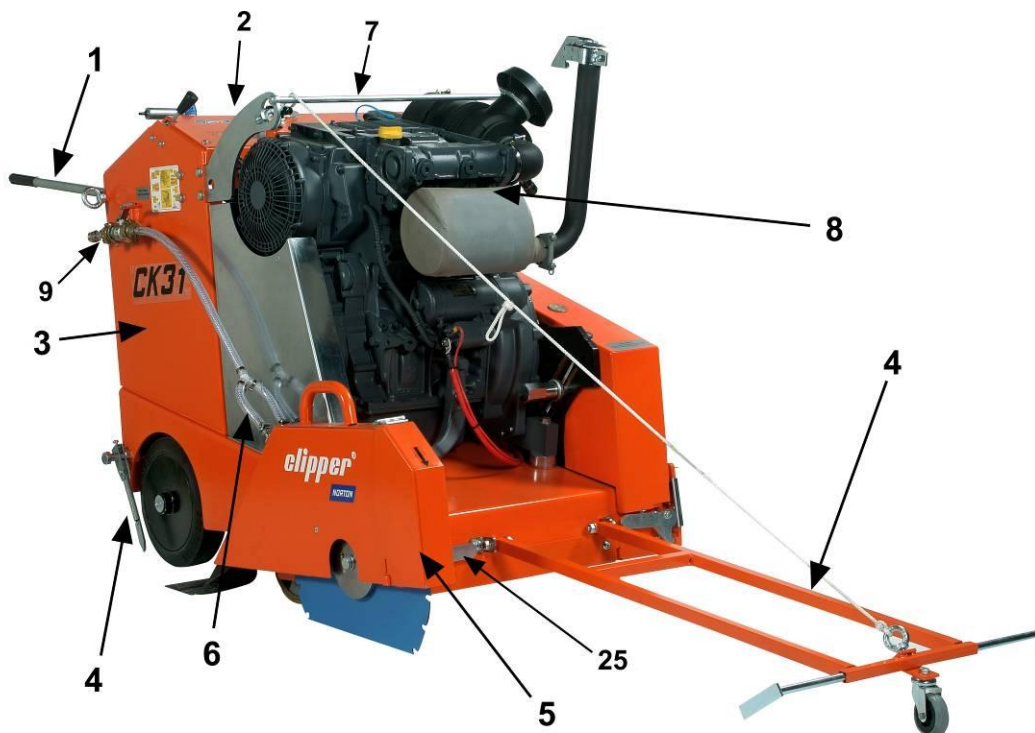

Made of jig welded open profile steel, the **CK31** is stable but at the same time, easily transportable.

The operator's handles (1) can be adjusted to a comfortable position, or removed for transportation. The main operating and safety components are in reach near the operator on the machine panel (2).

The engine frame (3) comprises the engine, the feed movement devices, and the hydraulic pump. The front and back pointers (4) allow the operator to make precise cuts easily.

The blade guard (5) fully protects the operator and his working environment. It is firmly fixed to the main frame. A small locking handle (25) can be opened to remove the guard to change blades. It can be opened on the front to cut up to a wall.

The water cooling system (6) is composed of a water tank tap (9) and two water nozzles on the blade guard ensuring adequate flow of water to both sides of the blade. External water supply has to be used by connecting to the palm coupling.

The machine can be lifted using the lifting eyes (7). The pivoting frame, hinged on the rear axle, is supporting the engine, the blade shaft assembly, and the protecting guards. 8 heavy-duty belts drive the blade.

The DEUTZ Motor F2L 2011 (8) with 31HP is started with a key. The following picture is showing the main control panel with its components:

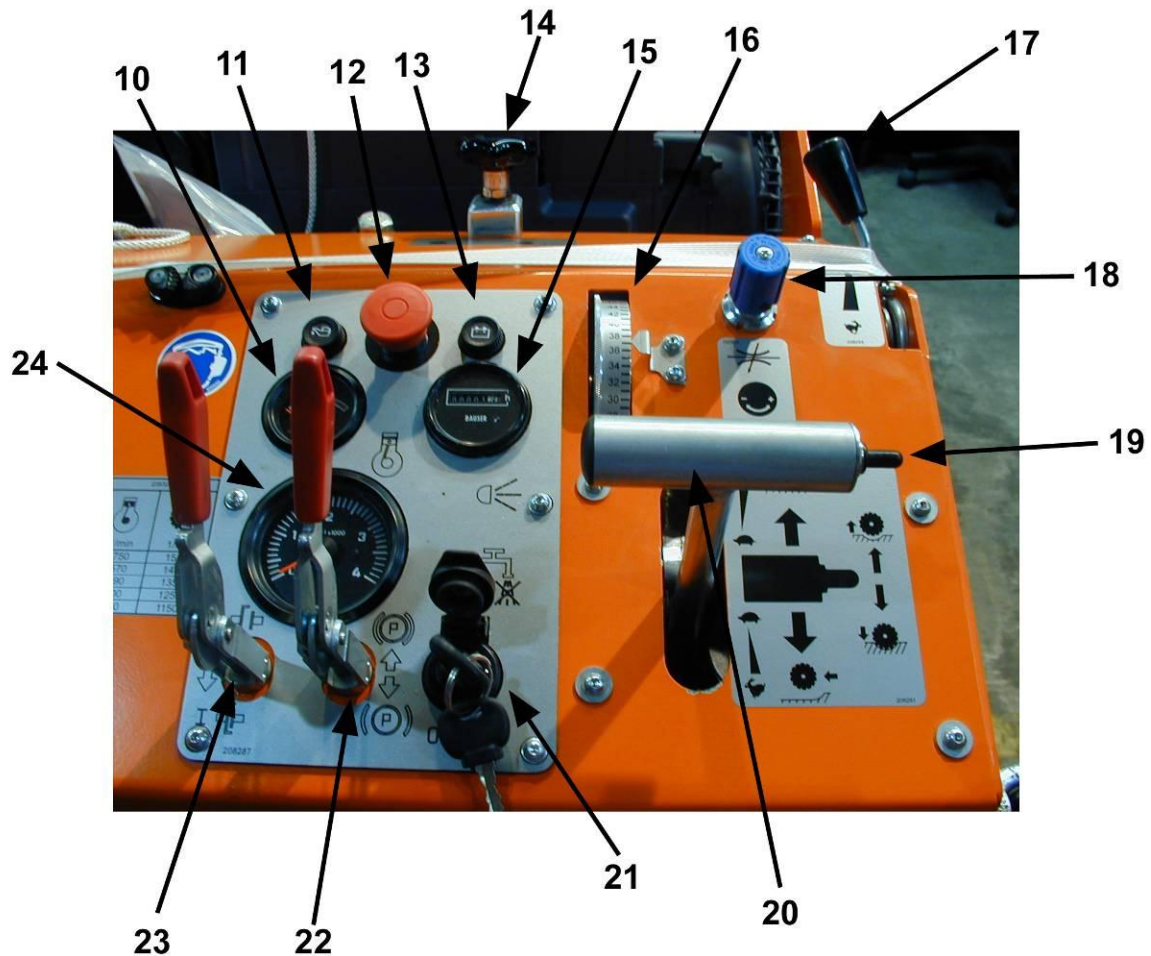

Two lights are showing the oil pressure (11) and the load of the battery (13). The emergency stop (12) is easy to reach for the operator. You can easily read the temperature of the engine (10) and the working time on the hour meter (15).

You can precisely set the depth of cut using the gauge (16), and make many cuts at the same depth using the maximum depth locking system (14). The blade is raised and lowered using the toggle switch (19). The speed of raise and lower is regulated using the control (18).

The machine is started using a key (21). The rotational speed of the engine is set with the handle (17), and can be checked with the tachometer (24). To move the machine, you have to take it off the parking position (22). You must then engage the clutch (23) and set the speed forward or backward with the handle (20).

2.3 Technical data

Engine	Deutz F2L 2011 (22,8kW/ 31HP)
Fuel	Diesel complying with the following minimum specifications : DIN EN590 or BS 2869 or ASTM D 975 – 1D / 2D or NATO Code F-54/f-34/f-44 or XF63
Oil (Motor)	Oil complying with the following minimum specifications: API CG4-CH-4 or ACEA E3-96+E4-98 or Deutz DQC II Viscosity recommended : SAE 10W-30 (outside temperature between -20°C and 30°C)
Oil (Reversing gear box)	Fully synthetic oil with a viscosity of SAE 90
Oil (Hydrostatic feed movement)	Hydraulic oil with a viscosity equivalent to the one of an automotive oil 20W-50
Oil (Hydraulic system)	Under 0°C : VG32 (As per ISO VG DIN51519) HLP32 (As per DIN51519) Cinematic viscosity at 40°C 22,8-35,2mm ² /s (cSI) 0-30°C : VG46 (As per ISO VG DIN51519) HLP48(As per DIN51519) Cinematic viscosity at 40°C 41,4-50,6mm ² /s (cSI) Over 30°C : VG68 (As per ISO VG DIN51519) HLP68(As per DIN51519) Cinematic viscosity at 40°C 61,2-74,8mm ² /s (cSI)
Fuel tank	30 L
Starter	Electric start with key
Blade raise system	Electro-hydraulic
Max. blade diameter	700 mm
Bore	25,4 mm
Max. cutting depth mm	280 mm
Flange diameter	150 mm
Blade shaft speed	1550 min ⁻¹
Driving belts	8
Machine dimensions (length x width x height)	1430x820x1280mm
Weight	660 kg
Max. operating weight	710 kg
Sound pressure level	100 dB (A) following ISO EN 11201
Sound energy level	114 dB (A) following ISO EN 3744

2.4 Vibration emission declaration

Declared vibration emission value in accordance with **EN 12096**

Machine Model / code	Measured vibration emission value a m/s²	Uncertainty K m/s²	Tool used Model / code
CK31 KSA 70184621027	9.4	0.8	CC Pro Ø700x25.4mm 70184624857

- Values determined according to procedure described in annex F of **EN 13862**
- Measurements are made with new machines. Real values in the field could vary the simple one with the double according to operating conditions, depending on:
 - Material
 - Cutting depth
 - Machine wear
 - Lack of maintenance
 - Tool not adapted to application
 - Tool in bad shape
 - Non-specialised operator
- Vibrations exposure time depends on cutting performance too (adaptation machine / tool / material / operator)
- When evaluating risks due to hand-arm vibration, you need to take into account effective usage at rated power of machine during a full day of work; quite often you will realise that effective utilisation time represents around 50% of overall duration of work. You have to consider, of course, breaks, water feeding, preparation of work, time to move the machine, disk mounting...

3 Assembly and commissioning

Before beginning the work with the CK31, you have to assemble some parts.

3.1 Tool assembly

Only use NORTON blades with the CK31.

A blade with a maximum diameter of 700 mm can be fitted. All tools used must be selected with regard to their maximum permitted cutting speed for the machine's maximum permitted rotation speed.

Before mounting a new blade, switch the machine off.

To assemble a new blade, follow these steps:

- Take the water nozzle off the blade guard.
- Release the locking handle (25).
- Take the blade guard (5) off the machine.
- Untighten the hexagonal screw on the blade shaft with the 19mm wrench. (CAUTION: on the right hand side of the machine, the screw is left-threaded, and the left hand side of the machine, the screw is right-threaded.)
- Remove the outer flange.
- Clean the flanges and blade shaft and inspect for wear.
- Mount the blade on the shaft ensuring that direction of rotation is correct. Wrong direction of rotation blunts the blade quickly.
- Replace outer blade flange.
- Tighten screw with 19mm wrench.
- Reassemble the blade guard and make sure it is securely tighten with the handle (25).
- Reconnect water nozzle.

The blade bore must correspond exactly to the blade shaft. Cracked or damaged bore is dangerous for the operator and for the machine.

3.2 Left or right cut

- Take the water nozzle off the blade guard.
- Release the locking handle (25).
- Take the blade guard (5) off the machine.
- Disassemble the flange cover from the other side of the machine, and reassemble on the side you used to have the blade guard.
- Assemble the blade as described in 3.1. on the side where you used to have your flange cover.
- Reassemble the blade guard making sure that the handle (25) is securely locked.

3.3 Water cooling system

Open water-tap (note that handle on water-tap should be in line with water-flow).

Ensure that water is flowing freely in the circuit and delivered adequately to both sides of the blade, as insufficient water supply may result in premature failure of the diamond blade.

In case of frost, empty the water cooling system.

3.4 Starting the machine

Make sure the blade is raised clear up the ground before starting the machine, and that the clutch is disengaged. Put the throttle lever (17) on the middle position.

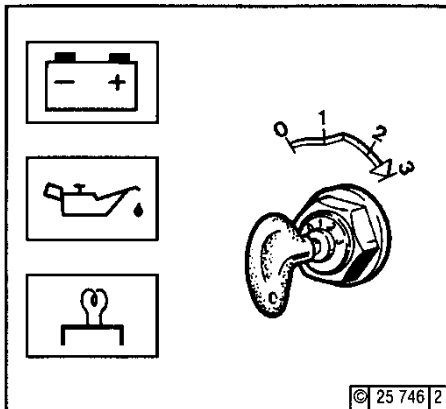

Insert the key (21)

You don't have any operating voltage in position 0.

Turn the key clockwise. In position 1, you have operating voltage. Therefore, the oil pressure light (11) and the battery load light should be on.

Push the key in and turn further clockwise against the spring pressure. The engine starts in position 3. Release the key as soon as the engine starts. The oil pressure light and the battery load light should go out.

Do not actuate the starter for more than 20 seconds. If the engine does not catch, wait a minute then try again. If the motor does not catch after 2 attempts, please refer to the Fault table (see 7.2) to check the problem.

The engine temperature meter (10) should remain in the green sector most of the time. It should rarely enter the yellow-green sector. If pointer enters the orange sector, engine is overheating. Turn off the machine, and establish cause from Fault table (see 7.2.).

4 Transport and Storing

Take the following measures in order to transport and store the CK31 securely.

4.1 *Securing for transport*

Before transporting the machine:

- Remove the blade.
- Empty the water system and disconnect the machine from the water supply.
- Raise the guide-a-cut in its upright position.
- Raise the cutting frame to its highest position.
- Take the key off the starter.

4.2 *Transport procedure*

The machine can be moved on a flat surface using its wheels.

a) Driving the machine

- Make sure the clutch is disengaged (23), the parking brake is tightened (22) and the speed handle is in middle position.
- Start the engine. Then engage the clutch and use the speed handle to move the machine backwards or forwards, and to regulate the speed.

b) Pushing the machine

Disengage the clutch of the machine (23) and the parking brake (22) and push it on the handle (1) without starting the motor.

c) Lifting using a crane

Make sure that crane can lift the weight of the machine. Use the metal lifting eye (7), located above the engine when lifting the CK31 with a crane. This lifting eye must not be used to lift the saw if the blade is stuck in the cut.

CAUTION: Nobody is allowed to go under the machine while it is lifted by the crane.

4.3 *Long period of inactivity*

If the machine is not going to be used for a long period, please take the following measures:

- Completely clean the machine.
- Loosen the drive belts.
- Change the motor oil.
- Disconnect one of the terminal of the battery so that the battery does not run empty
- Empty the water system.

The storage site must be clean, dry and at a constant temperature.

5 Operating the CK31

5.1 Site of work

Before you start working, please check the following points:

- Remove from the site anything, which might hinder the working procedure.
- Make sure the site is sufficiently well lit.
- Make sure you have a continual adequate view of the working area so you can intervene in the working process at any time.
- Keep other staff out of the area, so you can work securely.

5.2 Cutting method

In this section, you can find instructions to make a straight cut at the desired depth.

5.2.1 Preparing your cut

Before starting the machine,

- Draw a line on the floor over the cutting length.
- Make sure you have filled the engine tank with fuel, and the water tank with water, or that you have connected the blade guard to the water supply. No diesel is supplied with the machine.
- The engine is shipped with oil. Check oil level before starting. Top up if required (see 6.2.).
- Make sure you have assembled the correct blade as recommended by the manufacturer depending on the material to be worked, the working procedure (dry or wet cut) to be carried out, and the efficiency required.
- Make sure that the flanges securely hold the diamond blade.
- Make sure that the blade is not touching the floor before starting the engine.
- Roll the machine until the blade is over the line.
- Lower the guide-a-cut so it touches the line. The back guide should also be on this line.
- Set the speed handle in the middle position, so that if you engage the clutch, the machine will not move unexpectedly. Make also sure that the clutch is disengaged and the parking brake is tightened.

5.2.2 Cutting the floor

You can now start the engine.

To make your cut,

- Lower the pivoting frame until the blade slightly touches the floor. Then set the depth gauge to 0.
- Open water valve to control the amount of water required for the type of blade, using 15 to 25l/min for wet and 1-2l/min for dry cutting, dust control. Check for minimum water level regularly.
- Set the rotation of the blade with the throttle lever (17). You can check the speed on the meter (24).
- Lower blade into the cut. Once the required depth of cut is reached, you can release the parking brake, engage the clutch and use the back and forward handle to regulate speed. Always cut with the machine moving forward, as cutting backwards will damage the blade and the blade shaft. Follow the line with the pointer. The feed speed must be adjusted depending on the material being cut, and depth of cut.
- At the end of the cut, raise the blade out of the cut, switch off the engine and shut-off the water.

5.2.3 Locking of the cutting depth

If you have to make several cuts at the same depth, you can lock the maximum depth your machine will lower to. When you reach the depth for the first time, tighten the locking screw (14) until you reach the stop.

5.2.4 Setting of the direction

Because of the rotation of the blade, the floor saw cannot cut straight in normal operation. Therefore, you have to adjust the direction using the screw (30 below):

- If you turn the screw clockwise, the floor will turn right
- If you turn the screw anti-clockwise, the floor will turn left

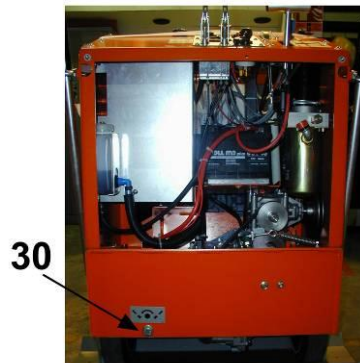

6 Maintenance and service

ATTENTION : to perform maintenance on the machine, always switch it off. Always wear a dust protection mask and safety goggles while performing the maintenance of the machine.

6.1 Maintenance of the machine

To ensure a long-term quality from the cutting with the CK31, please follow the maintenance plan below:

Regular service period Perform at every indicated period →		After one hour of work	Begin of the day	During the changing of the tool	End of the day	Every week	Every month	After a fault	Every year
		Whole machine	Visual control (general aspect, watertightness)						
	Clean								
Oil (hydrostatic)	Control and refill								
Flange and blade fixing devices	Clean								
Belts tension	Control								
Water hoses and nozzles	Clean								
Hydraulic hose and connectors	Control tightness								
Engine housing	Clean								
Reachable nuts and screws	Tighten up								
Reversing gear box	Change oil								
Hydrostatic feed movement	Change oil								
Grease nipple (pos.34 and 36)	Grease								
Grease nipple (pos. 35)	Grease								

Adjustment and replacement of the belts

After one hour of work, the belts heat and stretch. Therefore, you have to re-tension them.

To check the belts, remove the cap 31, and press with normal pressure on the belts. The displacement should be approx. from a belt thickness.

To adjust the belts' tension, loosen the nut (32) with the 36mm spanner. Then tighten the belts by turning the screw (33) (clockwise: increases belt tension). Then re-tighten the nut (32).

To change the belts, firstly remove the belt guard by untightening the 3 screws. Loose the nut (32) and turn the screw (33) until the belts are loose. Then put new belts on the pulleys and make sure the pulleys are well aligned. Re-assemble the belt guard and re-tension the belts with the screw (33). Then re-tighten the nut (32).

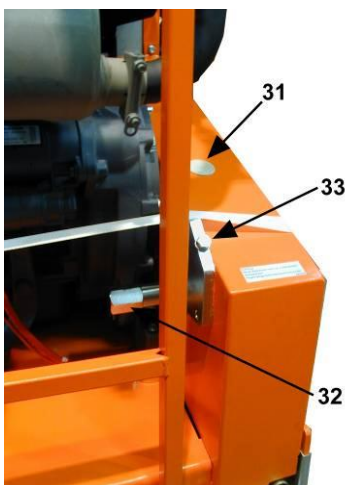

Always use a matched set of belts. Do not replace single belts. After controlling or retightening the belts, reassemble the belt guard on the frame of the machine.

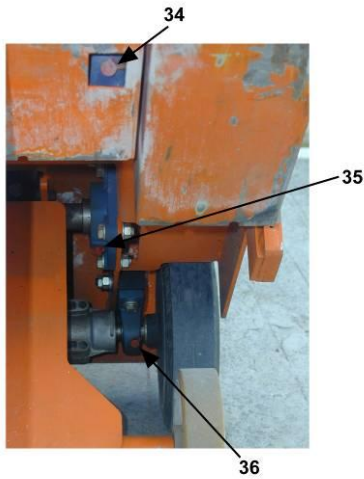

Grease

You must grease the nipples 34, 35 and 36 on both side of the machine regularly with Energrease LS2 BP.



Oil change for the hydraulic raise/lower system

The hydraulic unit (37) is first filled with hydraulic oil “BP-Batran HV-68”. The old oil can be removed from the unit through the filling hole. To remove the old oil, disassemble the unit and turn it over.

Oil change for the reversing gear box

Disassemble the gear box (38). Change the oil (SAE 90, fully synthetic, 0,35 litre) using the drain screw on the left side of the gear box. Then reassemble the gear box. Make sure than the belts are correctly tightened.

Oil change for the hydrostatic of the feed movement

Let the oil drain through the drain screw (40). Re-tighten then this screw. Disassemble the balancing tank (39) and empty it from its remaining oil. Reassemble the balancing tank and fill it with 4,6 litres engine oil 20W50.

CAUTION: Please dispose of used oil in a manner that is compatible with the environment. We suggest you to take used oil in a sealed container to your local recycling centre or service station for reclamation. Do not throw it in the trash, pour it on the ground or down in a drain.

Cleaning of the machine

Your machine will last longer if you clean it thoroughly after each day of work.

6.2 Maintenance of the engine

Regular service period Perform operating hour interval →		Each use	First month or 25 hours	Every 250 hours	Every 500 hours	Every 1000 hours
Engine oil	Check level (5)					
	Change (4)					
Oil filter	Change (2)					
Fuel filter	Change (3)					
Cooling air zone	Check-Clean					
Air cleaner filter	Clean (dry cut)					
	Clean (wet cut)					
	Change the cartridge					
Valve clearance (1)	Check and adjust (only to be done by a DEUTZ-specialist)					
Fuel filter	Replace					
Belt for alternator	Check					

Service place on the engine

1 Valve clearance adjustment: in. 0,3 mm / 0.012 in., ex. 0,5 mm / 0.020 in. Interval: 1000.

2 Oil filter change: BFM/BFL 500, FM/FL 1000.

3 Fuel filter change: FUEL 1000.

4 Oil change: h/Bh 125 - 2000.

5 Oil level check: OIL max. Interval: 10.

6 Air filter change: Interval: 1000.

2011 (with arrow pointing to the right)

DEUTZ®

Oil level check

When checking the oil level, the engine must be switched off, and should stand horizontal.

- Remove the oil dipstick
- Wipe the dipstick with a non-fibrous, clean cloth.
- Insert it to the stop and remove it again.
- Check oil level at the dipstick, and top up if necessary as far as the max. mark

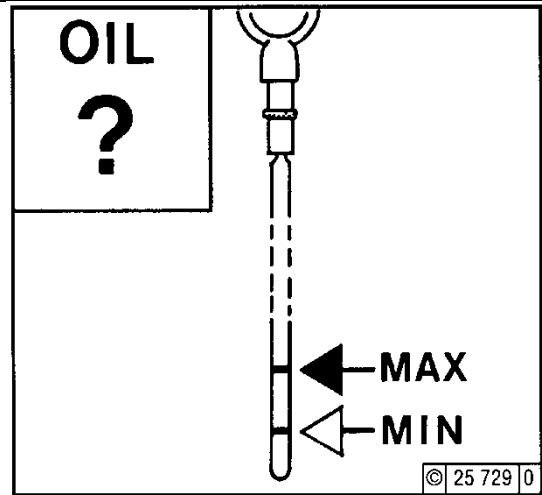

Changing oil

Allow the engine to warm up and then switch it off. Oil temperature is about 80°C. **CAUTION!** Risk of scalding from hot oil.

Please dispose of used engine oil in a manner that is compatible with the environment. We suggest you to take used oil in a sealed container to your local recycling centre or service station for reclamation. Do not throw it in the trash, pour it on the ground or down in a drain.

- Place an oil tray under the engine.
- Unscrew the oil drain plug.
- Drain the oil.
- Fit the oil drain plug with a new seal ring and tighten it firmly.
- Pour in new oil up to the MAX. mark on the dipstick.
- Check the oil level after having run the engine for a short period. Top up if necessary.

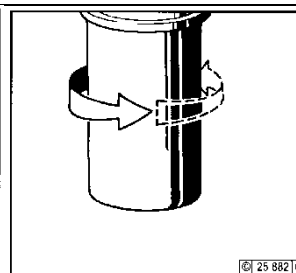
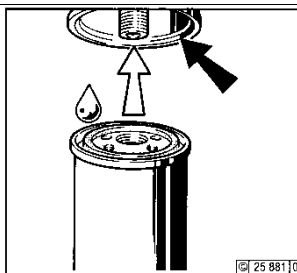
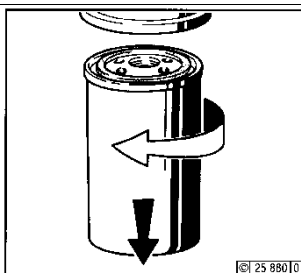
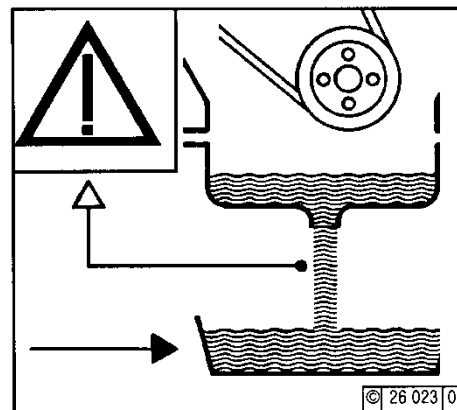

Changing the oil filter

- Undo the oil filter cartridge using commercial tool and spin off.
- Catch any escaping oil.
- Clean any dirt from the filter carrier sealing surface.
- Lightly oil the rubber gasket of the new oil filter cartridge.
- Manually screw in the new cartridge until gasket is flush.
- Tighten oil filter cartridge with another half-turn.
- Then check the oil level and the oil pressure.
- Check the filter cartridge seal for leaks.

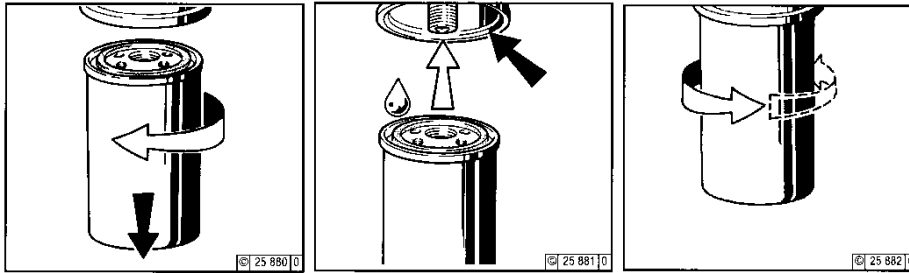

Changing the fuel filter

- **CAUTION:** Keep naked flames away when working on the fuel system. Do not smoke.
- Close the fuel shut-off valve.
- Undo the fuel filter cartridge using commercial tool and spin off.
- Catch any escaping fuel.
- Clean any dirt from the filter carrier sealing surface.
- Apply a light film of oil or diesel fuel to rubber gasket of new fuel filter cartridge.
- Manually screw in the new cartridge until gasket is flush.
- Tighten fuel filter cartridge with a final half-turn.
- Open the fuel shut-off valve.
- Check the filter cartridge seal for leaks.

Clean strainer of fuel filter

- **CAUTION:** Keep naked flames away when working on the fuel system. Do not smoke.
- Close fuel shut-off valve.
- Loosen and unscrew the hexagonal nut 1.
- Remove fuel strainer cover 2 (cover and strainer, one unit)
- Clean fuel strainer 2 with diesel fuel. Replace if necessary.
- Place seal 3 in position.
- Assemble fuel strainer cover 2.
- Tighten hexagonal screw 1.
- Check for leaks.

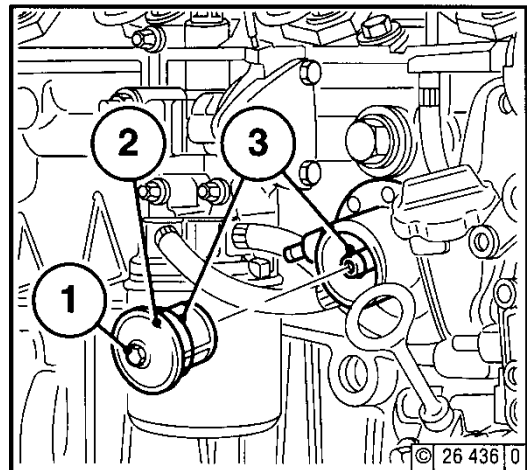

Air cleaner

If you use the machine in dry cut, you must clean the filter cartridge every day. Otherwise you must clean it when the indicator is showing red (1). To reset the indicator, press on the button.

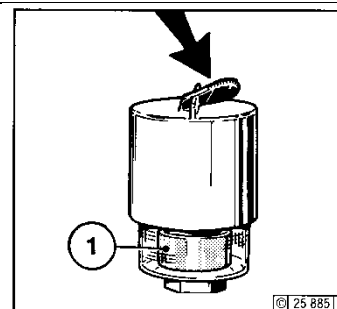

Air cleaner discharge valve

Empty dust discharge valve 1 by pressing apart lips of discharge as indicated by arrows. Clean the discharge slot from time to time. Remove any caked dirt by pressing together upper section of valve.

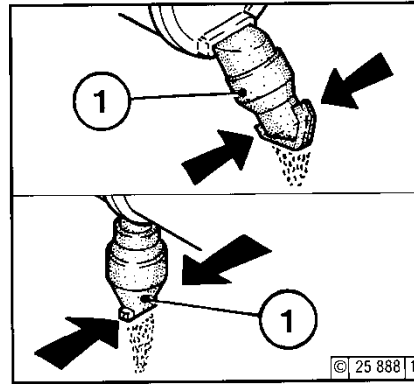

Filter cartridges

- Undo the clip fasteners 1.
- Take off the hood 2 and remove cartridge 3.
- Clean the cartridge, and replace it at least once a year.
- Clean cartridge 3 using compressed air (max. 5 bar). Blow out from inside to outside (or in difficult cases, tap out, taking care not to damage cartridge, or wash according to manufacturer's instructions.)
- Gaskets on filter cartridge can become damaged through regular removal and replacement. Check paper filter (light showing through) and gaskets for damage. Replace if necessary.
- After five cleaner services or after two years at latest, replace the safety cartridge 4 (never clean) by undoing the hexagonal nut 5 and removing the cartridge 4.
- Install the new cartridge 3, replace hood 2 and do up the clip fasteners 1.

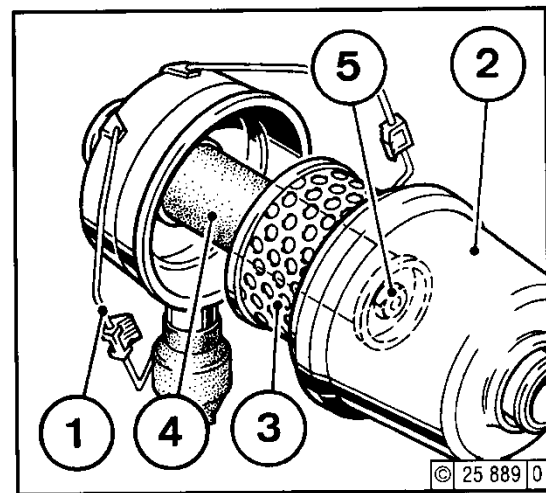

Alternator belts

- Slacken off bolts 1, 2 and 3.
- Adjust alternator 4 in direction of the arrow by turning the bolt 3 until correct belt tension is achieved.
- Retighten the bolts 1, 2 and 3.

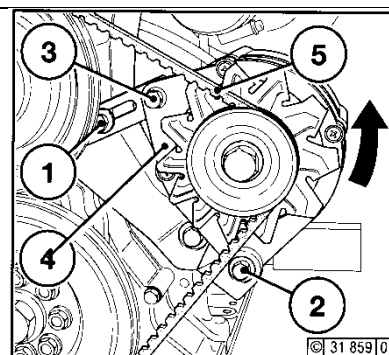

To change the belts,

- Slacken off bolts 1, 2 and 3.
- Adjust the alternator 4 in the direction of arrow by turning the bolt 3.
- Remove and replace the belt.
- Adjust alternator 4 against direction of arrow by turning bolt 3, until correct belt tension is achieved.
- Retighten bolts 1, 2 and 3.

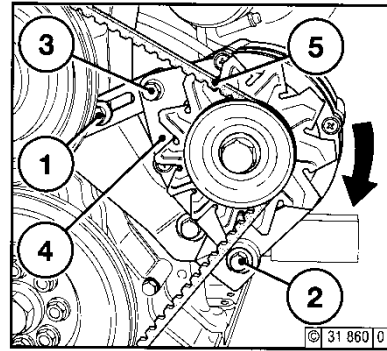

Control the valve clearance

Only a DEUTZ specialised dealer check the valve clearance. You also have to let a specialised dealer check your engine every 1000 hours of operation.

7 Faults: causes and cures

7.1 Fault-finding procedures

Should any fault occur during the use of the machine, turn it off. Let only qualified staff make any intervention other than the one described in the previous section.

7.2 Trouble-shooting guide

Trouble	Possible source	Resolution
Engine does not start or is difficult to start.	Fuel quality not as per operating manual	Change quality of diesel
	Incorrect oil class or quality	Change quality of oil
	Temperature too low	Use cold start oil
	Battery defective or discharged	Change or recharge battery
	Stronger fault	Contact nearest engine maintenance centre
Engine fires but stops again as soon as the crank is disengaged.	No oil pressure	Check the oil level
	Cylinder head temperature too high	Check cooling air passage
	Stronger fault	Contact nearest engine maintenance centre
Engine lacks power.	Tank run dry	Add fuel
	Air cleaner clogged	Clean or replace air filter
	Speed control lever does not remain in the selected position	Prevent speed control from moving
	Stronger fault	Contact nearest engine maintenance centre
Engine becomes excessively hot.	Air cleaner clogged	Clean or replace air filter
	Oil level too high or too low	Check oil level
	Belt to alternator broken or untightened	Check or change belt
Engine stops by itself during regular operation.	Tank run dry	Add fuel
	Air filter restricted	Clean or replace air filter
	No oil pressure	Check the oil level
	Stronger fault	Contact nearest engine maintenance centre

7.3 Customer service

When ordering spare parts, please mention:

- The serial number (seven digits).
- The code of the part.
- The exact denomination.
- The number of parts required.
- The delivery address.
- Please indicate clearly the means of transportation required such as "express" or "by air".
Without specific instructions, we will forward the parts through the means which seem appropriate to us and but which is not always the quickest way.

Clear instructions will avoid problems and faulty deliveries.

If not sure, please send us the defective part.

In the case of a warranty is claim, the part must always be returned for evaluation.

Spare parts for the engine can be ordered with the manufacturer of the engine or with their dealer, which is often quicker and cheaper.

This machine has been manufactured by Saint-Gobain Abrasives S.A.

190, Bd. J.F.Kennedy
L- 4930 BASCHARAGE
Grand-Duché de Luxembourg.

Tel. : 00352-50401-1

Fax : 00352- 50 16 33

<http://www.construction.norton.eu>

e-mail: sales.nlx@saint-gobain.com

Guarantee can be claimed and technical support obtained from your local distributor where machines, spare parts and consumables can be ordered as well:

Benelux and France:

From Saint-Gobain Abrasives
in the Grand-Duché de Luxembourg
Free telephone numbers:
Belgium : 0 800 18951
France: 0 800 90 69 03
Holland: 0 8000 22 02 70
e-mail: sales.nlx@saint-gobain.com

Germany

Saint-Gobain Diamond Products GmbH
Birkenweg 45-49,
D-50389 WESSELING
Tel : (02236) 8911 0
Fax : (02236) 8911 30
e-mail: sales.ngg@saint-gobain.com

Hungary

Saint-Gobain Abrasives KFT.
Banyaleg Utca 60B
H-1225 BUDAPEST
Tel: ++36 1 371 2250
Fax: ++36 1 371 2255
e-mail: nortonbp@axelero.hu

Czech Republic

Norton Diamantove Nastroje Sro
Vinohradska 184
CS-13000 PRAHA 3
Tel: 0042 0267 13 20 21
Fax: 0042 0267 13 20 21
e-mail: norton.diamonds@komerce.cz

Poland

Saint-Gobain Diamond Products Sp.zO.O.
AL. Krakowska 110/114
PL-00-971 WARSZAWA
Tel: 0048 22 868 29 36
Tel/Fax: 0048 22 868 29 27
e-mail: norton-diamond@wp.pl

United Kingdom

Saint-Gobain Abrasives Ltd.
Doxey Road
Stafford
ST16 1EA
Tel : 0845 602 6222
Free fax : 0800 622 385
e-mail : nortondiamonduk@saint-gobain.com

Italy

Saint-Gobain Abrasivi S.p.A.
Via per Cesano Boscone, 4
I-20094 CORSICO-MILANO
Tel: 0039 02 44 851
Fax: 0039 0245 101238
e-mail: Norton.edilizia@saint-gobain.com

Spain

Saint-Gobain Abrasivos S.A.
C/. Verneda del Congost s/n
Pol.Ind. El Pedregar
E-08160 MONTMELÓ (Barcelona)
Tel: 0034 935 68 68 70
Fax: 0034 935 68 67 14
e-mail : Comercial.sga-apa@saint-gobain.com

Austria

Saint-Gobain Abrasives GmbH
Telsenberggasse 37,
A-5020 SALZBURG
Tel: 0043 662 43 00 76 77
Fax: 0043 662 43 01 75
e-mail: office@sga.net

www.construction.norton.eu

Saint-Gobain Abrasives

190, Bd. J. F. Kennedy
L-4930 BASCHARAGE
LUXEMBOURG

Tel: ++352 50401-1

Fax: ++352 501633

e-mail: sales.nlx@saint-gobain.com