

NORTON

SAINT-GOBAIN

clipper

Transforming
surfaces
...and beyond

CS 451 P13

OPERATING INSTRUCTIONS

Translation of the original instructions





CE Declaration of conformity

The undersigned manufacturer:

SAINT - GOBAIN ABRASIVES S.A.
190, BD. J. F. KENNEDY
L-4930 BASCHARAGE

Declares that this product:

« Floor saw »: **CS 451 P13**

Code : **70184628433**

is in conformity with the following Directives :

- **"MACHINES" 2006/42/CE**
- **"ELECTROMAGNETIC COMPATIBILITY" 2014/30/EU**
- **"NOISE" 2000/14/CE**

And the European standard:

- **EN 13862 – Floor cutting-off machines – Safety**

Valid for machines as of serial number:

70100000

Storage site for the technical documents:

Saint-Gobain Abrasives 190, Bd. J. F. Kennedy 4930 BASCHARAGE, LUXEMBOURG

This declaration of conformity loses its validity when the product is converted or modified without agreement.

Bascharage, Luxembourg, 27.03.2024



Fabrice Genuardi, executive officer and responsible for the technical file.
Bascharage, Luxembourg.



Declaration of conformity

The undersigned manufacturer:

SAINT - GOBAIN ABRASIVES S.A.
190, BD J.F. KENNEDY
L- 4930 BASCHARAGE

Declares that this product:

Floor Saw: **CS 451 P13**

Code: **70184628433**

is in conformity with the following standard:

- ***Supply of Machinery (Safety) Regulations 2008***
- ***Electromagnetic Compatibility Regulations 2016***
- ***Noise Emission in the Environment by Equipment for use Outdoors Regulations 2001***

and European standard:

- ***EN 13862 – Floor cutting-off machines – Safety***

Valid for machines with a serial number greater than: 70100000

Authorised Representative:

SAINT-GOBAIN ABRASIVES

Unicorn House • Unit 1, Amison Close

Redhill Business Park • Stafford • England • ST16 1WB

This declaration of conformity loses its validity when the product is converted or modified without agreement.

Bascharage, Luxembourg, 27.03.2024

A handwritten signature in black ink, appearing to read 'Genuardi', written over a light blue horizontal line.

Fabrice Genuardi, executive officer and responsible for the technical file.
Bascharage, Luxembourg.

CS 451 P13

OPERATING INSTRUCTIONS

<u>1</u>	<u>BASIC SAFETY INSTRUCTIONS</u>	<u>6</u>
1.1	<i>Symbols</i>	6
1.2	<i>Machine plate</i>	7
1.3	<i>Safety instructions for particular operating phases</i>	8
<u>2</u>	<u>GENERAL DESCRIPTION OF THE CS 451</u>	<u>9</u>
2.1	<i>Short description</i>	9
2.2	<i>Layout</i>	10
2.3	<i>Technical data</i>	12
2.4	<i>Statement regarding the vibration emission</i>	13
2.5	<i>Statement regarding noise emission</i>	14
<u>3</u>	<u>ASSEMBLY AND COMMISSIONING</u>	<u>15</u>
3.1	<i>Operator's handle assembly</i>	15
3.2	<i>Tool assembly</i>	15
3.3	<i>Water cooling system</i>	15
3.4	<i>Starting the machine</i>	16
<u>4</u>	<u>TRANSPORT AND STORING</u>	<u>17</u>
4.1	<i>Securing for transport</i>	17
4.2	<i>Transport and lifting procedure</i>	17
4.3	<i>Long period of inactivity</i>	17
<u>5</u>	<u>OPERATING THE CS 451</u>	<u>18</u>
5.1	<i>Site of work</i>	18
5.2	<i>Cutting method</i>	18
<u>6</u>	<u>MAINTENANCE AND SERVICE</u>	<u>20</u>
6.1	<i>Maintenance of the machine</i>	20
6.2	<i>Maintenance of the engine</i>	21
<u>7</u>	<u>BREAKDOWNS: CAUSES AND CURES</u>	<u>24</u>
7.1	<i>Breakdown-finding procedures</i>	24
7.2	<i>Trouble-shooting guide</i>	24
7.3	<i>Customer service</i>	25
7.4	<i>Spare parts</i>	26

1 BASIC SAFETY INSTRUCTIONS

The CS 451 is exclusively designed for the cutting of floors made of asphalt, green and cured concrete (reinforced or not) as well as of industrial cement.

Uses other than the manufacturer's instructions shall be considered as contravening the regulations. The manufacturer shall not be held responsible for any resulting damage. Any risk shall be borne entirely by the user. Observing the operating instructions and compliance with inspection and servicing requirements shall also be considered as included under use in accordance with the regulations.

1.1 Symbols

Important warnings and pieces of advice are indicated on the machine using symbols. The following symbols are used on the machine:



Read operator's instructions



Ear protection must be worn



Hand protection must be worn



Eye protection shall be worn



Cutting depth indicator



Danger: risk of cut

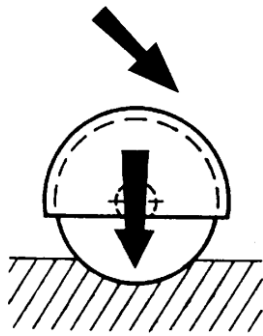

Rotation of the wheel in the indicated direction lowers the blade

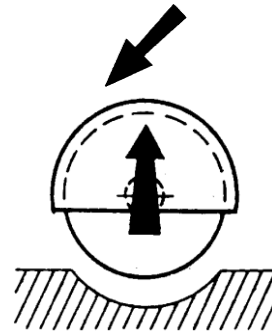

Rotation of the wheel in the indicated direction raises the blade

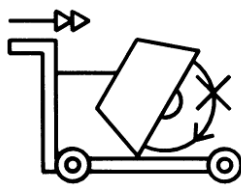

Never move the machine with the blade running idle.







Rotation direction of the blade



Emergency Stop

1.2 Machine plate

Important data can be found on the following plate located on the machine:

 190, Bd. J.F. Kennedy L-4930 BASCHARAGE LUXEMBOURG	Code: Machine Code	Year: Year of production	 = Ø Maximum blade mm	UK CA CE EAC
	Mod: Machine Model	W= Weight kg	 = Ø Bore mm	
	EN: Safety standard	P= Power kW	 = Blade speed RPM	
	Type: Machine type	Serial N°: Serial number		

1.3 Safety instructions for particular operating phases

Before commencing work

- Before commencing work, make yourself familiar with the working environment at the place of use. The working environment includes: obstacles in the area of work and manoeuvre, the firmness of the floor, necessary protection at the site relating to public thoroughfares and the availability of help in the event of accidents.
- Check for correct mounting of the blade regularly.
- Immediately remove damaged or badly worn blades, as they endanger the operator whilst rotating.
- Always cut with the blade guard in position.
- Only fit NORTON diamond blades to the machine! The use of other tools can damage the machine!
- Read the blades' specifications carefully to choose the correct tool for your application.
- Attention is drawn to the use of BS2092 safety goggles in conformity with specified Processes No.8 of the Protection of Eyes Regulation 1974, Regulation 2(2) Part 1. Also use the other safety equipment as mentioned in the symbols plus a dust mask when dry cutting is applied.
- For security reasons, never leave the machine unattended, untied or unlocked.

While the engine is running

- Do not move the machine whilst the blade is running idle.
- Do not run the machine without the security guards in place.
- Apply cooling water continuously whilst cutting and in good time (even when dry cutting to avoid dust)!

Petrol powered machines:

- Always use the fuel advised.
- In confined areas, exhaust gases should be evacuated and the job site properly aerated.
- Petrol and diesel machines, which by their nature emit toxic exhaust gases, must not be used in places prohibited by the Health at Work etc. Act 1974 or which are prohibited by Factory Inspectors or Safety Officers.
- Fuel is flammable. Before filling the tank, shut down the engine, extinguish all open flames and do not smoke. Take care that no petrol is spilled on any motor part. Always wipe up spilled fuel.

2 GENERAL DESCRIPTION OF THE CS 451

Any modification, which could lead to a change in the original characteristics of the machine, may be done only by Saint-Gobain Abrasives S.A. who shall confirm that the machine is still in conformity with the safety regulations. Saint-Gobain Abrasives S.A. keeps the right of making technical or design modification without prior notification.

2.1 *Short description*

The **Floor Saw CS 451** you have chosen is used for small repair works in concrete and asphalt, for cutting induction loops and installing cables as well as for cutting expansion joints. It can be used either for wet or dry cutting operations.

An optimized mass repartition and positioning of 25 litre water tank allow outstanding cutting performance as well as easy handling.

Operator can use specific devices to set cutting depth and track easily.

Ergonomic handles height can be set at right value whatever the cutting depth; handles feature a built-in vibration absorbing device.

Reinforced frame reduces vibration level as well as operator's fatigue.

CS 451 has taper lock pulleys and Poly-V belt for better reliability and easy maintenance.

Being of small construction, it can be transported in a car or van; the handle can be removed, reversed or retracted. The 25 litre water container is also removable.

All component parts on the **CS 451** are assembled to a high quality standard, ensuring long life, reliability and a minimum of maintenance.

Special types of blades are available for asphalt, green concrete, cured concrete (reinforced or not) as well as for industrial cement flooring.

2.2 Layout

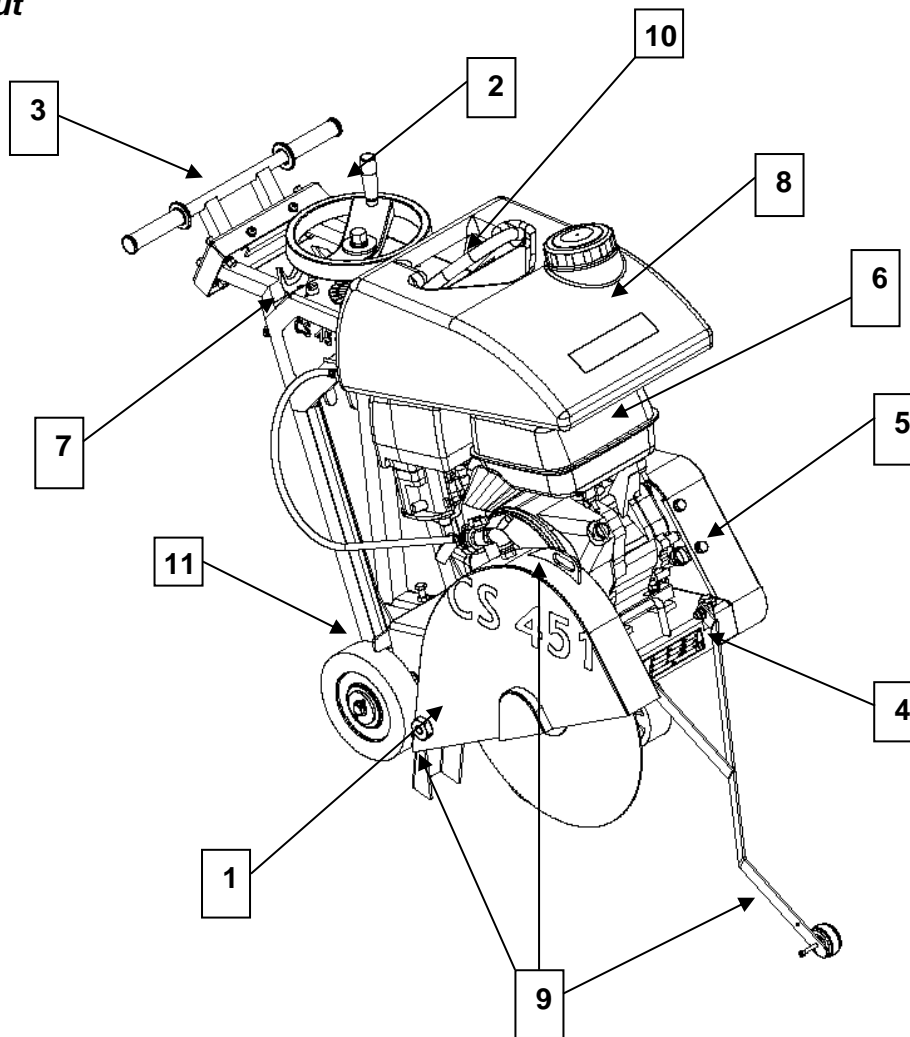

Made of jig welded open profile steel, the **CS 451** is stable but at the same time, easily transportable.

The one-piece blade guard (1) fully protects the operator and his working environment. It is firmly fixed to the main frame but can be opened by rotation to change blades.

A manually operated hand wheel mechanism (2) enables graduated depth setting. Turning the hand wheel clockwise or anti-clockwise will lower or raise the cutting blade. A depth gauge allows the operator to control precisely the depth of cut.

The handle (3) is detachable or can be reversed for easy transportation. The height is adjustable whatever the cutting depth. A specific built-in device reduces vibrations.

Machine frame is designed in a way to reduce vibrations too, improving working conditions.

The pivoting frame (4), hinged on the rear axle, is supporting the engine, the blade shaft assembly, and the protecting guards. **Poly-V** belt drives the blade.

The precisely manufactured blade shaft is fitted into two heavy-duty self-aligning pillow block
10

bearings, including grease nipples. On one end is a Poly-V pulley with taper lock and on the other end the shaft is reduced to 25,4mm, allowing an inner flange to be fixed. Outer flange is assembled on the shaft with a 36mm locking nut.

(A 20 mm thick spacer flange and an outer flange, with dowel pinholes, can be provided as accessories)

The steel belt guard (5) is a sealed two piece unit. The backing plate is bolted to the mainframe of the machine and locking nuts are welded to it. The outer guard, covering the Poly-V belt and taper lock pulleys, is held in place by four locking bolts.

The 13 HP Honda GX390 engine (6) is connected to an emergency shut down switch (7) on the right side of the machine near the levers. This allows an immediate stop of the machine in case of danger.

The water cooling system (8) is composed of a 25 litre water tank, a water tank tap and two water nozzles located on the blade guard ensuring adequate flow of water to both sides of the cutting blade. This system can be connected directly to tap water too.

The pointers (9) allow the operator to make precise cut easily.

The set including front cutting guide, guide attached to blade cover, and rear cutting guide allow to align easily and accurately blade with cutting line.

A hook (10) allows the CS 451 to be lifted in an easy and well balanced way.

Parking brake (11) secures the machine when it is not running.

2.3 Technical data

Engine	Honda GX390, 4 stroke, 1 cylinder, 13HP (9,6kW)
Fuel	Automotive unleaded gasoline with a pump octane rating of 86 or higher (research octane rating of 91 or higher)
Oil	Honda 4-Stroke, or equivalent high detergent, premium quality motor oil certified to meet or exceed U.S. automobile manufacturer's requirement for service classification SG, SF. (SG, SF designated on the oil container). SAE 10W-30 recommended
Starter	Manual pull cord
Air filter	Cyclone type
Max. blade diameter	450 mm
Bore	25,4 mm
Max. cutting depth mm	170 mm
Flange diameter	108 mm
Blade shaft speed	2573 min ⁻¹
Driving belt	Poly-V 698PK10
Water tank	25 l
Machine dimensions (length x width x height)	1180 x 538 x 1040 mm in cutting configuration
Weight	112 kg
Max. operating weight	145 kg
Sound pressure level	88 dB (A) (ISO EN 11201)
Sound energy level	105 dB (A) (ISO EN 3744)
Vibration emission value	2.8 m/s ² (according to EN 12096)

2.4 Statement regarding the vibration emission

Declared vibration emission value in accordance with **EN 12096**

Machine Model / code	Measured vibration emission value a m/s ²	Uncertainty K m/s ²	Tool used Model / code
CS 451 P13 70184628433	2.8	0.5	Duo Extreme Ø350x25.4

- Values determined according to procedure described in annex F of **EN 13862**
- Measurements are made with new machines. Real values in the field could vary the simple one with the double according to operating conditions, depending on:
 - Material
 - Cutting depth
 - Machine wear
 - Lack of maintenance
 - Tool not adapted to application
 - Tool in bad shape
 - Non-specialised operator
- Vibrations exposure time depends on cutting performance too (adaptation machine / tool / material / operator)
- When evaluating risks due to hand-arm vibration, you need to take into account effective usage at rated power of machine during a full day of work; quite often you will realise that effective utilisation time represents around 50% of overall duration of work. You have to consider, of course, breaks, water feeding, preparation of work, time to move the machine, disk mounting...

2.5 Statement regarding noise emission

Declared value of noise emission following **EN ISO 11201** and **NF EN ISO 3744**.

Machine Model / code	Sound Pressure level L_{Peq} EN ISO 11201	Uncertainty K (Sound Pressure level L_{Peq} EN ISO 11201)	Sound power level L_{Weq} NF EN ISO 3744	Uncertainty K (Sound power level L_{Weq} NF EN ISO 3744)
CS 451 P13 70184628433	88 dB(A)	2.5 dB(A)	105 dB(A)	4 dB(A)

- Values determined using the procedure described in the standard **EN 13862**.
- The measurements are made with new machines. Actual values may vary with site conditions, in terms of:
 - Wear Machine
 - Lack of maintenance
 - Inappropriate tool for application
 - Tool in poor condition
 - Unskilled operator
 - Etc...
- Measured values relate to an operator in normal use, as described in the manual position.

3 ASSEMBLY AND COMMISSIONING

Before beginning the work with the CS 451, you have to assemble some parts.

3.1 *Operator's handle assembly*

Secure the operator's handle in a comfortable user position by using the locking screws.

3.2 *Tool assembly*

Only NORTON blades with a maximum diameter of 450 mm can be fitted on the CS 451. A blade with a maximum diameter of 450 mm can be fitted. All tools used must be selected with regard to their maximum permitted cutting speed for the machine's maximum permitted rotation speed. Before mounting a new blade, switch the machine off.

To mount a new blade, follow these steps:

- Turn the hand wheel until the pivoting frame is in the raised position.
- Loosen the screws maintaining the guard and turn the blade guard open.
- Loosen the hexagonal nut (**attention:** left hand thread).on the blade shaft, which holds the removable outer flange. Remove the nut and the outer flange Remove the nut and the outer flange.
- Clean the flanges and blade shaft and inspect for wear.
- Mount the blade on the shaft ensuring that direction of rotation (arrow on blade steel centre) is correct. Wrong direction of rotation blunts the blade quickly.
- Put in place outer blade flange.
- Tighten hexagonal nut with spanner supplied for this purpose (left hand thread).
- Close the blade guard and tighten the screws.

ATTENTION! The blade bore must correspond exactly to the blade shaft. Cracked or damaged bore is dangerous for the operator and for the machine.

3.3 *Water cooling system*

Fill in the water tank with clean water.

Open tank water-tap (note that handle on water-tap should be in line with water-flow).

Ensure that water is flowing freely in the circuit and delivered adequately to both sides of the blade, as insufficient water supply may result in premature failure of the diamond blade or excessive dust generation.

If needed, adjust water flow with blade guard water tap.

In case of frost, empty the water cooling system.

3.4 Starting the machine

Make sure the blade is raised clear up the ground before starting the machine.

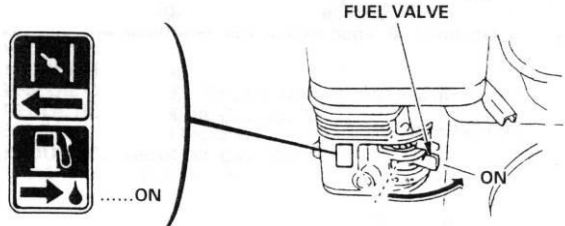
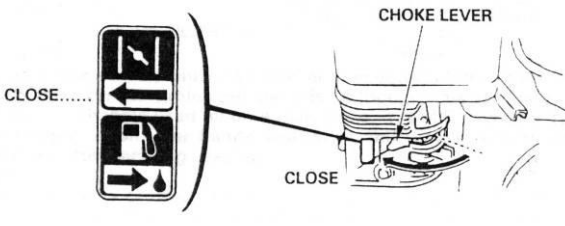
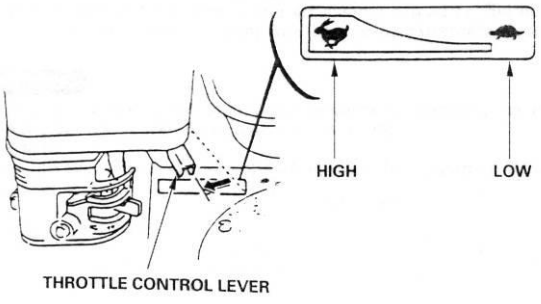
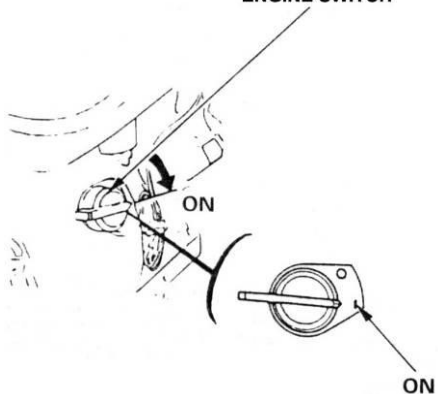
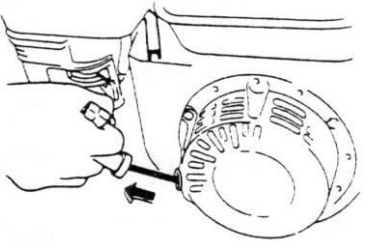
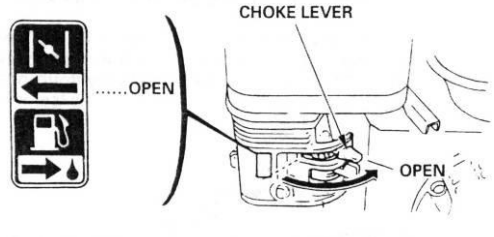
	
<p>Turn the fuel valve to the ON position.</p>	<p>Move the choke lever to the CLOSED position. NOTE: do not use the choke if the engine is warm or the air temperature is high.</p>
	
<p>Move the throttle control lever slightly to the left.</p>	<p>Put the engine switch on ON, and make sure the emergency switch on the board of the machine is in the ON position.</p>
	
<p>Pull the starter grip lightly until you feel resistance, then pull briskly. CAUTION: Do not allow the starter grip to snap back against the engine. Return it gently to prevent damage to the starter.</p>	<p>As the engine warms up, gradually move the choke lever to the OPEN position. Position the throttle control lever for the maximum engine speed (full left).</p>

To stop the engine, move the throttle control lever fully to the right, then turn the engine switch to the OFF position. Turn the fuel valve to the OFF position.

4 TRANSPORT AND STORING

Take the following measures in order to transport and store the CS 451 securely.

4.1 *Securing for transport*

Before transporting the machine:

- Remove the blade.
- Empty the water tank.
- Lower the handle in its fixing tube and secure it using the locking screws.
- Raise the guide-a-cut in its upright position.
- Raise the cutting head to its highest position using the hand wheel, in order to activate the parking brake.

4.2 *Transport and lifting procedure*

The machine can be moved on a flat surface using its wheels. Use the metal hook located over the water tank to lift the machine with a crane. **Utilization of other part of the machine (e.g. handles) is absolutely prohibited.**

4.3 *Long period of inactivity*

If the machine is not going to be used for a long period, please take the following measures:

- Completely clean the machine.
- Loosen the drive belt.
- Grease the threaded shaft.
- Possibly change the motor oil.
- Empty the water system.
- Activate the parking brake by raising the cutting head.

The storage site must be clean, dry and at a constant temperature.

5 OPERATING THE CS 451

5.1 Site of work

Before you start working, please check the following points:

- Remove from the site anything, which might hinder the working procedure.
- Make sure the site is sufficiently well lit.
- Place, when used, the water hose so that it can't be damaged
- Make sure you have a continual adequate view of the working area so you can intervene in the working process at any time.
- Keep other staff out of the area, so you can work securely.

5.2 Cutting method

In this section, you can find instructions on how to make a straight cut at the desired depth.

5.2.1 Preparing your cut

Before starting the machine,

- Draw a line on the floor over the cutting length.
- Make sure you have filled the engine tank with fuel, and the water tank with water, our, when possible, the machine is connected to the water net. No petrol is supplied with the machine.
- The engine is shipped with oil. Check oil level before starting. Top up if required.
- Make sure you have mounted the correct blade as recommended by the manufacturer depending on the material to be worked, the working procedure (dry or wet cut) to be carried out, and the efficiency required.
- Make sure that the flanges securely hold the diamond blade.
- Make sure that the blade is not touching the floor before starting; you can turn the hand wheel up to the mechanical stop.
- Adjust the handle to a comfortable position.
- Roll the machine until the blade is over the line.
- Lower the guide-a-cut so it touches the line.
- Align front cutting guide, guide attached to blade cover and rear cutting guide with the line.

5.2.2 Cutting the floor

You can now start the engine.

To make your cut,

- Turn the depth hand wheel until the blade slightly touches the floor.
- Open water valve to control the amount of water required for the type of blade, using 15 to 25l/min for wet cutting and 1-2l/min for dry cutting (dust control). Check for minimum water level regularly when using the water tank.
- To lower blade into the cut, turn hand wheel clockwise. Each turn of the hand wheel will raise or lower the blade by 10mm.
- Once the required depth of cut is reached, push the machine forward with steady and gentle pressure and follow the line with the cutting guides. The feed speed must be adjusted depending on the material being cut, and depth of cut.
- At the end of the cut, raise the blade out of the cut by turning the hand wheel anti-clockwise, shut-off the water and switch off the engine.

6 MAINTENANCE AND SERVICE

CAUTION: to perform maintenance of the machine, always switch it off. Always wear a mask and safety goggles while performing the maintenance of machine.

6.1 Maintenance of the machine

To ensure a long-term quality from the cutting with the CS 451, please follow the maintenance plan below:

		Regular service period Perform at every indicated period →						
		After one hour of work	Beginning of the day	During tool change	End of the day	Once a week	After a failure	After a damage
Whole machine	Visual control (general aspect, sealing)							
	Clean							
Flange and blade fixing devices	Clean							
Belt tension	Control							
Water hoses and nozzles	Clean							
Depth screw	Grease							
Engine housing	Clean							
Reachable nuts and screws	Tighten up							

Adjustment and replacement of the belt

After one hour of work, the belt heats up and stretches. Therefore, you have to re-tighten it.

To adjust the belt, firstly remove the belt guard by unscrewing the 4 nuts. Loose the 4 engine bolts and shift the engine by using the two screws on the front. Then tighten the 4 bolts.

To replace the belt, move the engine completely to the front. Adjust the belt and retighten it by shifting the motor to the rear. Then tighten the 4 bolts.

Lubrication

The CS 451 uses life-lubricated bearings. Therefore, you don't need to lubricate them at all. Grease the depth screw once a week.

Cleaning of the machine

Your machine will last longer if you clean it thoroughly after each working day.

6.2 Maintenance of the engine

		Regular service period Perform at every indicated month or operating hour interval, whichever comes first			
		→			
		Each use	First month or 20 hours	Every 3 months or 50 hours	Every 6 months or 100 hours
Engine oil	Check level				
	Change				
Air Cleaner filter	Check				
	Clean				
Fuel strainer cup	Clean				
Spark plug	Check-Clean				
Fuel line	Check (Replace if necessary)	Every 2 years			

Engine oil

To change the oil,

- Remove the oil filler cap/dipstick and drain bolt.
- Allow the oil to drain completely.
- Dispose of used motor oil in a manner that is compatible with the environment. We suggest you to take used oil in a sealed container to your local recycling centre or service station for re-treatment. Do not throw it in the trash, pour it on the ground or down in a drain.
- Reinstall the drain bolt, and tighten it to 18 N.m.
- Fill the crankcase with the engine oil to the outer edge of the oil filler neck.
- Reinstall the filler cap/dipstick.

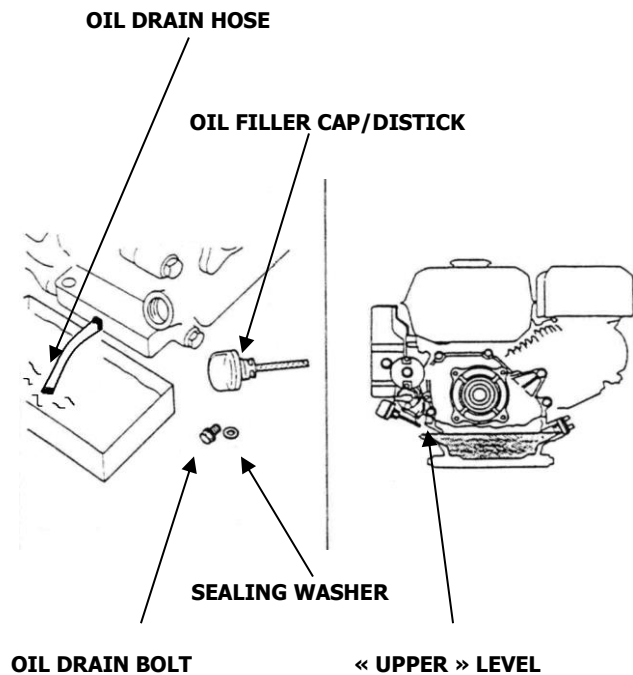

Air Cleaner

CS 451 has a dual type filter.

To service the air cleaner filter, remove the blade and the water tank from the machine, and drive the engine support in its lowest position using the hand wheel. Follow these instructions:

- Remove the nut, air cleaner cover and wing nut.

- Remove the pre air cleaner elements and separate them.
- Carefully check both elements for holes or tears and replace if damaged.
- **Paper element:** tap element lightly several times on a hard surface to remove excess dirt or blow compressed air lightly through the filter from the inside out. Never brush the dirt off; brushing will force dirt into the fibres.
- **Foam element:** clean in warm soapy water, rinse and allow drying thoroughly. Dip the element in clean engine oil and squeeze out all the excess. The engine will smoke during initial start-up if too much oil is left in the foam.
- Shine a light through the elements, and inspect them carefully. Reinstall the elements if they are free of holes and tears.

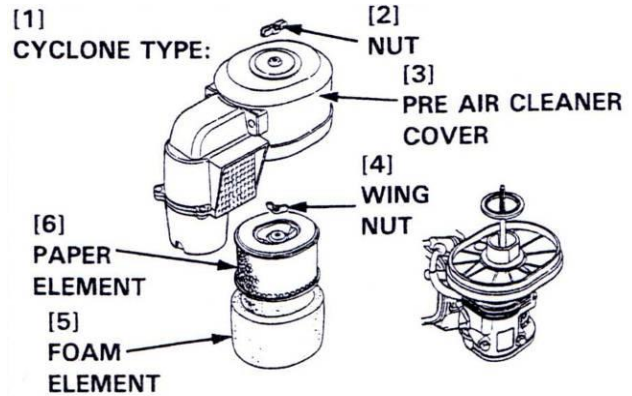

Cyclone filter

When the cyclone housing becomes dirty, unscrew the three special pan screws and wipe or wash the components with water. Next, thoroughly dry the components and carefully reassemble them. When reinstalling the cyclone, ensure that the tab on the air intake fits properly into the groove in the pre-cleaner cap. Be careful to install the air guide in the proper direction.

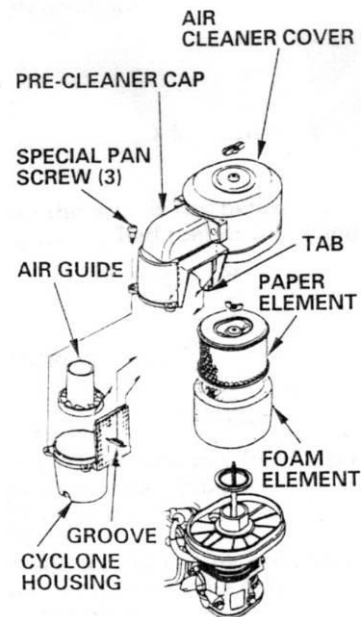

Fuel strainer cup

To service fuel strainer cup, follow these instructions:

- Turn off the fuel valve and remove the strainer cup.
- Clean the strainer cup with solvent.
- Install the O-ring and strainer cup.
- Tighten the strainer cup to 4N.m.

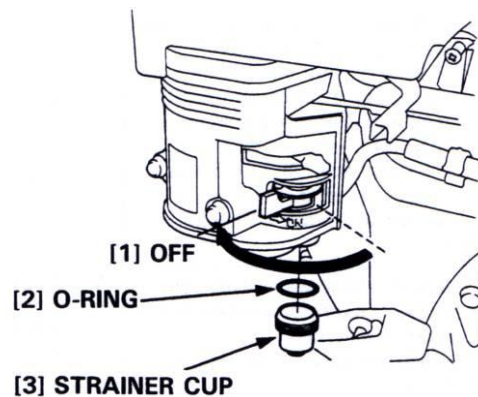

Spark plug

To service the spark plug, follow these instructions:

- Visually inspect the spark plug. Discard the plug if the insulator is cracked or chipped.
- Remove carbon or other deposits with a stiff wire brush.
- Measure the plug gap with a wire-type feeler gauge. If necessary, adjust the gap by bending the side electrode.
- Make sure the sealing washer is in good condition; replace the plug if necessary.
- Install the plug finger tight to seat the washer, then tighten with a plug wrench (an additional ½ turn if a new plug) to compress the sealing washer. If you are reusing a plug, tighten 1/8-1/4 turn after the plug seats.

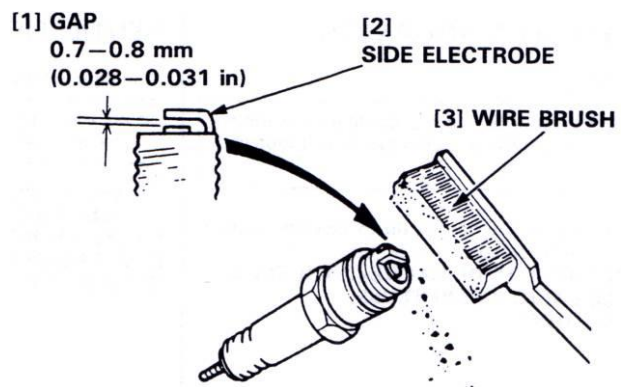

Fuel line

To service the fuel line, follow these instructions:

- Drain the fuel into a suitable container, and remove the fuel tank.
- Disconnect the fuel line, and unscrew the fuel filter from the tank.
- Clean the filter with solvent, and check, that the filter screen is undamaged.
- Place the O-ring on the filter and reinstall. Tighten the filter to 2N.m. After reassembly, check for fuel leaks.

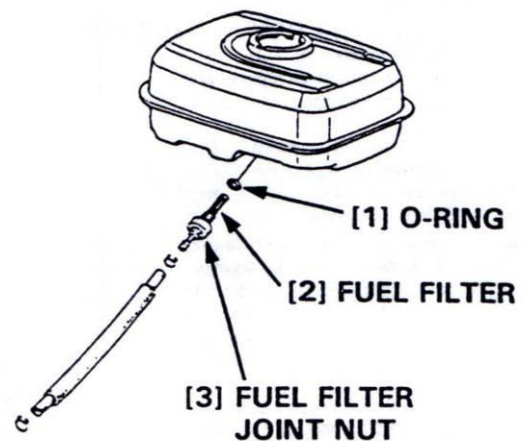

Further maintenance

For further maintenance, please contact the nearest engine maintenance centre.

7 BREAKDOWNS: CAUSES AND CURES

7.1 Breakdown-finding procedures

Should any breakdown occur during the use of the machine, turn it off. Let only qualified staff make any intervention other than the ones described in the previous section.

7.2 Trouble-shooting guide

Trouble	Possible source	Resolution
Difficult to start	Not enough fuel	Fill fuel tank
	Fuel filter clogged	Clean fuel filter
	Spark plug faulty	Inspect spark plug
	Stronger fault	Contact nearest engine maintenance centre
Engine lacks power	Air filter restricted	Clean or replace air filter
	More serious fault	Contact nearest engine maintenance centre

7.3 Customer service

When ordering spare parts, please mention:

- The serial number (7 digits).
- The code of the part.
- The exact denomination.
- The number of parts required.
- The delivery address.
- Please indicate clearly the means of transportation required such as "express" or "by air". Without specific instructions, we will forward the parts through the means which seem appropriate to us - -- but which is not always the quickest way.

Clear instructions will avoid problems and faulty deliveries.

If not sure, please send us the defective part.

In the case of a warranty claim, the part must always be returned for evaluation.

Spare parts for the motor can be ordered with the manufacturer of the motor or with their dealer, which is often quicker and cheaper.

This machine has been manufactured by: Saint-Gobain Abrasives S.A.

190, Bd. J. F. Kennedy

L- 4930 BASCHARAGE

Grand-duché de Luxembourg.

Tel.: 00352-50 401-1

<http://www.construction.norton.eu>

e-mail: sales.nlx@saint-gobain.com

7.4 Spare parts

In order to consult the spare parts lists, we invite you to visit the after-sales website of Norton Clipper by using the following address:

<https://spareparts.nortonabrasives.com>

For a quick access, you can also use the QR Code shown below using your mobile phone:



This electronic catalogue provides exploded views and spare parts lists for different machines designed by Norton Clipper so you can find references you need.

Guarantee can be claimed, and technical support obtained from your local distributor where machines, spare parts and consumables can be ordered as well:

SAINT-GOBAIN ABRASIVES
INDUSTRIEWEG 21
9420 ERPE-MERE
BELGIUM
TEL: +32(0) 2 267 21 00

SAINT-GOBAIN CONSTRUCTION PRODUCTS
CZ A.S
DIVIZE ABRASIVES
SMRČKOVA 2485/4
180 00 PRAHA 8
CZECH REPUBLIC
TEL: +420 255 719 326
FAX: +420 255 719 321

SAINT-GOBAIN ABRASIVES A/S
DYBENDALSVÆNGET 2,
DK-2630 TAASTRUP
DENMARK
TEL: +45 4675 5244

PO BOX 643706
FORTUNE TOWER OFFICE 2106
JLT BLOCK C
(NEXT TO METRO STATION)
JUMEIRA LAKE TOWER, DUBAI
UNITED ARAB EMIRATES
TEL: +971 4 431 5154
FAX: +971 4 431 5434

SAINT-GOBAIN ABRASIFS
RUE DE L'AMBASSADEUR - B.P.8
78 702 CONFLANS CEDEX
FRANCE
TEL: +33 (0)1 34 90 40 00
FAX: +33 (0)1 39 19 89 56

SAINT-GOBAIN ABRASIVES GMBH
BIRKENSTRASSE 45-49
D-50389 WESSELING
GERMANY
TEL: +49 (0) 2236 703-0
FAX: +49 (0) 2236 703-730

SAINT-GOBAIN ABRASIVES KFT.
1225 BUDAPEST
BÁNYALÉG U. 60/B.
HUNGARY
TEL: +36 1 371 22 50
FAX: +36 1 371 22 55

SAINT-GOBAIN ABRASIVI S.P.A
VIA PER CESANO BOSCONI 4
I-20094 CORSICO MILANO
ITALY
TEL: +39 02 44 851
FAX: +39 02 44 78 266

SAINT-GOBAIN ABRASIVES S.A.
190 RUE J.F. KENNEDY
L-4930 BASCHARAGE
GRAND DUCHE DE LUXEMBOURG
TEL: +352 50 401 1
FAX: +331 83 717 792
NO. VERT (FRANCE): 0800 906 903

SAINT-GOBAIN ABRASIFS, S.A.
2 ALLÉE DES FIGUIERS
AIN SEBAÂ - CASABLANCA
MOROCCO
TEL: +212 5 22 66 57 31
FAX: +212 5 22 35 09 65

SAINT-GOBAIN ABRASIVES BV
GROENLOSEWEG 28
7151 HW EIBERGEN
P.O. BOX 10
7150 AA EIBERGEN
THE NETHERLANDS
TEL: +31 545 466466
FAX: +31 545 474605

SAINT-GOBAIN ABRASIVES AS
KARIHAUGVEIEN, 89
0186 OSLO
NORWAY
TEL: +47 63 87 06 00
FAX: +47 63 87 06 01

SAINT-GOBAIN HPM POLSKA SP. Z O.O.
UL. NORTON 1, 62-600 KOŁO
62-600 KOŁO
POLAND
TEL: +48 63 26 17 100
FAX: +48 63 27 20 401

SAINT-GOBAIN ABRASIVOS, L. DA
ZONA INDUSTRIAL DA MAIA
I-SECTOR VIII, NO. 122
APARTADO 6050
4476 - 908 MAIA
PORTUGAL
TEL: +351 229 437 940
FAX: +351 229 437 949

SAINT-GOBAIN GLASS
BUSINESS UNIT ABRASIVI
PUNCT DE LUCRU : LOC.VETIS, JUD.
SATU MARE 447355
STR. CAREIULUI 11
PARC INDUSTRIAL RENOVATIO
ROMANIA
TEL: +40 261 839 709
FAX: +40 261 839 710

SG HPM RUS
58, F. ENGELS STR.
STROENIE 2
105082 MOSCOW
RUSSIA
TEL: +74 955 408 355
FAX: +74 959 373 224

SAINT-GOBAIN
ABRASIVES (PTY) LTD
2 MONTEER ROAD
ISANDO 1600
P.O. BOX 67
SOUTH AFRICA
TEL: +27 11 961 2000
FAX: +27 11 961 2184/5

SAINT-GOBAIN ABRASIVOS, S.A.
CTRA. DE GUIPÚZCOA, KM. 7,5
E-31195 BERRIOPLANO (NAVARRA)
SPAIN
TEL: +34 948 306 000
FAX: +34 948 306 042

SAINT GOBAIN ABRASIVES AB
GÅRDSFOGDEVÄGEN 18A
168 66 BROMMA • SVERIGE
SWEDEN
TEL: +46 8 580 881 00
FAX: +46 8 580 881 30

SAINT-GOBAIN INOVATIF MALZEMELER VE
ASINDIRICI SAN. TIC. AS.
ALTAYÇEŞME MAH. ÇAMLI SOK. NO:21 ESAS
OFISPAK KAT:9 34843
MALTEPE, İSTANBUL • TURKEY
TEL: 0090-216-217 12 50
FAX: 0090-216-442 40 74

SAINT-GOBAIN ABRASIVES LTD.
UNICORN HOUSE UNIT 1, AMISON CLOSE
REDHILL BUSINESS PARK
STAFFORD ST161WB
UNITED KINGDOM
TEL: +44 1785 279 553
FAX: +44 1785 213 487



Saint-Gobain Abrasifs
190 Rue J.F. Kennedy
L-4930 Bascharage
Grand Duche de Luxembourg
Tel: +352 50 401 1
Fax: +331 83 717 792
no. vert (France) 0800 906 903

www.nortonabrasives.com/fr-fr