

CS1 P13

OPERATING INSTRUCTIONS

Translation of the original instructions



clipper®



SAINT-GOBAIN

CE **Declaration of conformity**

The undersigned manufacturer:

SAINT - GOBAIN ABRASIVES S.A.
190, BD. J. F. KENNEDY
L-4930 BASCHARAGE

Declares that this product:

« Floor saw »: **CS1 P13 HONDA Cyclonic**
CS1 P13 HONDA Cyclonic Ø500

Code : **70184624214**
70184629389

is in conformity with the following Directives :

- **"MACHINES" 2006/42/CE**
- **"ELECTROMAGNETIC COMPATIBILITY" 2014/30/UE**
- **"NOISE" 2000/14/CE**

And the European standard:

- **EN 13862 – Floor cutting-off machines – Safety**

Valid for machines as of serial number:
70100000

Storage site for the technical documents:
Saint-Gobain Abrasives 190, Bd. J. F. Kennedy 4930 BASCHARAGE, LUXEMBOURG

This declaration of conformity loses its validity when the product is converted or modified without agreement.

Bascharage, Luxembourg, 13/10/2021.



François Chianese, executive officer.



Declaration of conformity

The undersigned manufacturer:

SAINT - GOBAIN ABRASIVES S.A.
190, BD J.F. KENNEDY
L- 4930 BASCHARAGE

Declares that this product:

Floor saw : **CS1 P13 HONDA Cyclonic**
CS1 P13 HONDA Cyclonic Ø500

Code : **70184624214**
70184629389

is in conformity with the following standard:

- **Supply of Machinery (Safety) Regulations 2008**
- **Electromagnetic Compatibility Regulations 2016**
- **Noise Emission in the Environment by Equipment for use Outdoors Regulations 2001**

and European standard:

EN 13862 – Floor cutting-off machines – Safety

Valid for machines with a serial number greater than: 70100000

Authorised Representative:

SAINT-GOBAIN ABRASIVES

Unicorn House • Unit 1, Amison Close

Redhill Business Park • Stafford • England • ST16 1WB

This declaration of conformity loses its validity when the product is converted or modified without agreement.

Bascharage, Luxembourg, 01.10.2021

François Chianese, executive officer.

CS1 P13

OPERATING INSTRUCTIONS

<u>1</u>	<u>BASIC SAFETY INSTRUCTIONS</u>	6
1.1	<i>Symbols</i>	6
1.2	<i>Machine plate</i>	7
1.3	<i>Safety instructions for particular operating phases</i>	8
<u>2</u>	<u>GENERAL DESCRIPTION OF THE CS1</u>	9
2.1	<i>Short description</i>	9
2.2	<i>Layout</i>	9
2.3	<i>Technical data</i>	11
2.4	<i>Statement regarding the vibration emission</i>	12
2.5	<i>Statement regarding noise emission</i>	13
<u>3</u>	<u>ASSEMBLY AND COMMISSIONING</u>	14
3.1	<i>Tool assembly</i>	14
3.2	<i>Water cooling system</i>	14
3.3	<i>Starting the machine</i>	15
<u>4</u>	<u>TRANSPORT AND STORING</u>	16
4.1	<i>Securing for transport</i>	16
4.2	<i>Transport procedure</i>	16
4.3	<i>Long period of inactivity</i>	16
<u>5</u>	<u>OPERATING THE CS1</u>	17
5.1	<i>Site of work</i>	17
5.2	<i>Cutting method</i>	17
<u>6</u>	<u>MAINTENANCE AND SERVICE</u>	18
6.1	<i>Maintenance of the machine</i>	18
6.2	<i>Maintenance of the engine</i>	19
<u>7</u>	<u>FAULTS: CAUSES AND CURES</u>	22
7.1	<i>Fault-finding procedures</i>	22
7.2	<i>Trouble-shooting guide</i>	22
7.3	<i>Customer service</i>	23

1 BASIC SAFETY INSTRUCTIONS

The CS1 is exclusively designed for the cutting of floors made of asphalt, green and cured concrete (reinforced or not) as well as of industrial cement.

Uses other than the manufacturer's instructions shall be considered as contravening the regulations. The manufacturer shall not be held responsible for any resulting damage. Any risk shall be borne entirely by the user. Observing the operating instructions and compliance with inspection and servicing requirements shall also be considered as included under use in accordance with the regulations.

1.1 Symbols

Important warnings and pieces of advice are indicated on the machine using symbols. The following symbols are used on the machine:



Read operator's instructions



Ear protection must be worn



Hand protection must be worn



Eye protection shall be worn

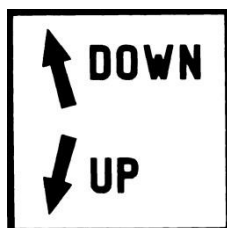

The rotation of the hand wheel in the direction shown : up or down the blade



Danger: risk of cut

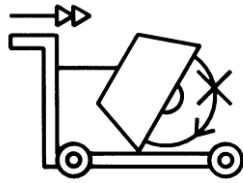

Never move the machine with the blade running idle.



Rotation direction of the blade



Emergency Stop

1.2 Machine plate

Important data can be found on the following plate located on the machine:

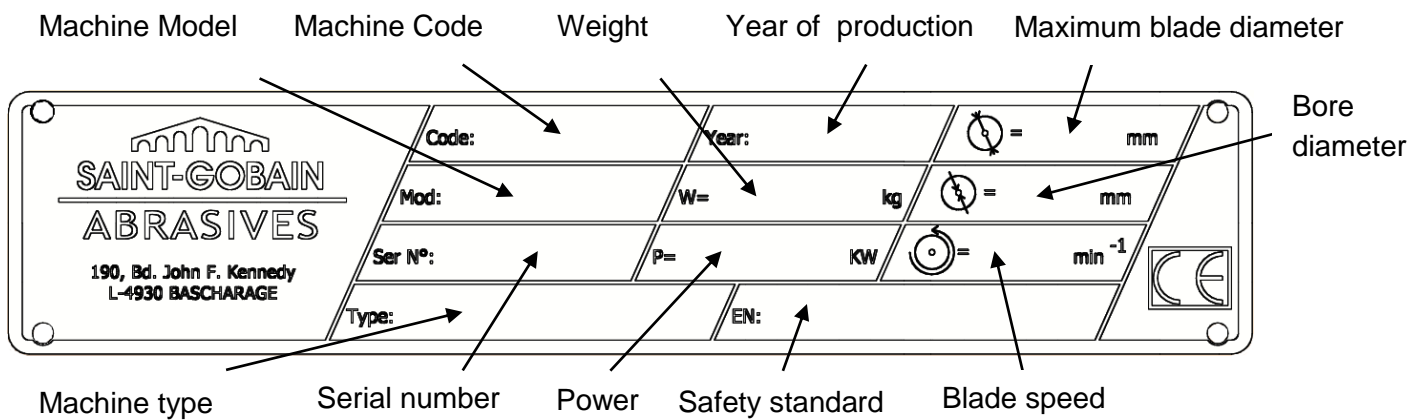

1.3 Safety instructions for particular operating phases

Before commencing work

- Before commencing work, make yourself familiar with the working environment at the place of use. The working environment includes: obstacles in the area of work and manoeuvre, the firmness of the floor, necessary protection at the site relating to public thoroughfares and the availability of help in the event of accidents.
- Check for correct mounting of the blade regularly.
- Immediately remove damaged or badly worn blades, as they endanger the operator whilst rotating.
- Always cut with the blade guard in position.
- Only fit NORTON diamond blades to the machine! The use of other tools can damage the machine!
- Attention is drawn to the use of BS2092 safety goggles in conformity with specified Processes No.8 of the Protection of Eyes Regulation 1974, Regulation 2(2) Part 1.
- For security reasons, never leave the machine unattended, untied or unlocked.

While the engine is running

- Do not move the machine whilst the blade is running idle.
- Do not run the machine without the security guards in place.
- Apply cooling water continuously whilst cutting and in good time!

Diesel powered machines:

- Always use the fuel advised.
- In confined areas, exhaust gases should be evacuated and the job site properly aerated.
- Diesel machines, which by their nature emit toxic exhaust gases, must not be used in places prohibited by the Health at Work Act 1974 or which are prohibited by Factory Inspectors or Safety Officers.
- Diesel is flammable. Before filling the tank, shut down the engine, extinguish all open flames and do not smoke. Take care that no diesel is spilled on any motor part. Always wipe up spilled fuel.

2 GENERAL DESCRIPTION OF THE CS1

Any modification, which could lead to a change in the original characteristics of the machine, may be done only by Saint-Gobain Abrasives S.A. who shall confirm that the machine is still in conformity with the safety regulations. Saint-Gobain Abrasives S.A. keeps the right of making technical or design modification without prior notification.

2.1 Short description

The **Floor Saw CS1** you have chosen, is used for small repair works in concrete and asphalt, for cutting induction loops and installing cables as well as for cutting expansion joints. It can be used for either wet or dry cutting operations. Being of small construction, it can be transported in a car or van. The water container is enclosed in the frame. All component parts on the **CS1** are assembled to a high quality standard, ensuring long life, reliability and a minimum of maintenance. Special types of blades are available for asphalt, green concrete, cured concrete (reinforced or not) as well as for industrial cement flooring.

2.2 Layout

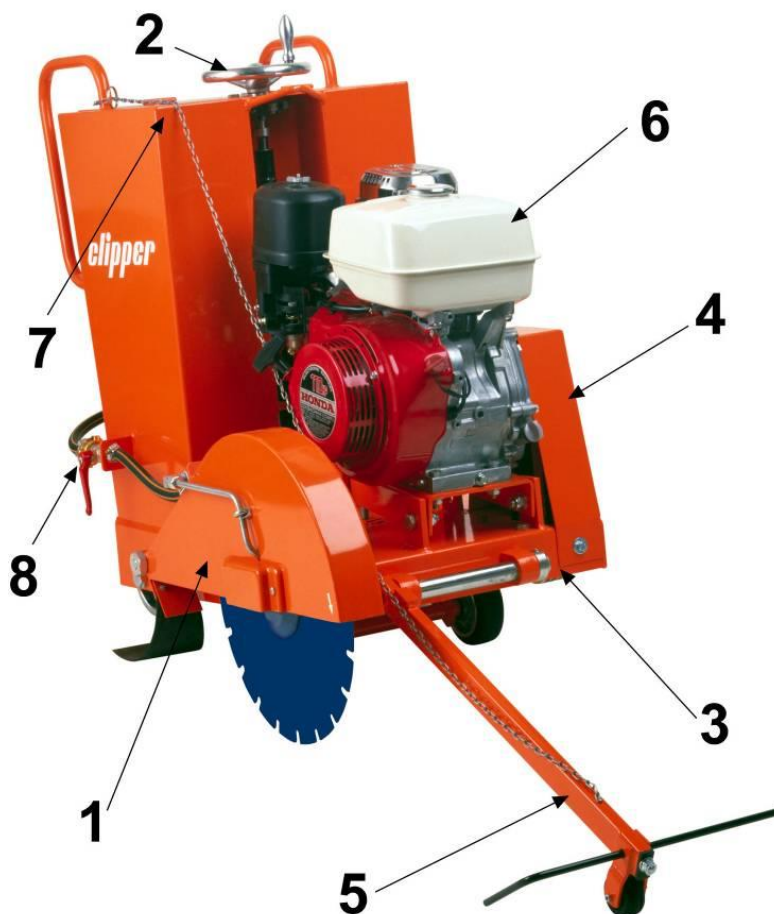

Made of jig welded open profile steel, the **CS1** is stable but at the same time, easily transportable.

The one-piece blade guard (1) fully protects the operator and his working environment. It is firmly fixed to the main frame but can be opened by rotation to change blades.

A manually operated hand wheel mechanism (2) enables graduated depth setting. Turning the hand wheel clockwise or anti-clockwise will lower or raise the cutting blade.

The pivoting frame (3), hinged on the rear axle, is supporting the engine, the blade shaft assembly, and the protecting guards. Four heavy-duty belts drive the blade.

The precisely manufactured blade shaft is fitted into two heavy-duty self-aligning pillow block bearings, including grease nipples. A four-belt taper lock pulley is fitted on one end. The shaft is reduced to 25,4mm at the other end, allowing an inner flange complete with dowel pinholes to be fixed.

The steel belt guard (4) is bolted to the mainframe of the machine. It is covering the four drive belts and pulleys for protection of the environment while the machine is running. The pointer (5) allows the operator to make precise cut easily.

The Honda GX390 engine (6) is connected to an emergency shut down switch (7) on the board of the machine. This allows an immediate stop of the machine in case of danger.

The water cooling system (8) is composed of a 70 litres water tank, a water tank tap and two water nozzles on the blade guard ensuring adequate flow of water to both sides of the blade.

2.3 Technical data

Engine	Honda GX390, 4 strokes, 1 cylinder, 13HP (9,6kW)
Fuel	Automotive unleaded gasoline
Oil	Honda 4-Stroke, or equivalent high detergent, premium quality motor oil certified to meet or exceed U.S. automobile manufacturer's requirement for service classification SG, SF. (SG, SF designated on the oil container). SAE 10W-30 recommended
Starter	Manual pull chord
Air filter	Dual type (machine type 99277, 99556, 99557, and 99558) Cyclone type (machine type 99939)
Max. blade diameter	500 mm
Bore	25,4 mm
Max. cutting depth mm	190 mm
Flange diameter	115 mm
Blade shaft speed	2600 min ⁻¹
Driving belts	4
Water tank	70 l
Machine dimensions (length x width x height)	1088x580x925mm
Weight	140 kg
Max. operating weight	220 kg
Sound pressure level	89 dB (A) following ISO EN 11201
Sound energy level	105 dB (A) following ISO EN 3744

2.4 Statement regarding the vibration emission

Declared vibration emission value in accordance with **EN 12096**

Machine Model / code	Measured vibration emission value a m/s ²	Uncertainty K m/s ²	Tool used Model / code
CS1 P13 HONDA Cyclonic 70184624214	4.22	0.5	Clipper Super Beton Evo
CS1 P13 HONDA Cyclonic Ø500 70184629389			

- Values determined according to procedure described in annex F of **EN 13862**
- Measurements are made with new machines. Real values in the field could vary the simple one with the double according to operating conditions, depending on:
 - Material
 - Cutting depth
 - Machine wear
 - Lack of maintenance
 - Tool not adapted to application
 - Tool in bad shape
 - Non-specialised operator
- Vibrations exposure time depends on cutting performance too (adaptation machine / tool / material / operator)
- When evaluating risks due to hand-arm vibration, you need to take into account effective usage at rated power of machine during a full day of work; quite often you will realise that effective utilisation time represents around 50% of overall duration of work. You have to consider, of course, breaks, water feeding, preparation of work, time to move the machine, disk mounting...

2.5 Statement regarding noise emission

Declared value of noise emission following **EN ISO 11201** and **NF EN ISO 3744**.

Machine Model / code	Sound Pressure level L_{Peq} EN ISO 11201	Uncertainty K (Sound Pressure level L_{Peq} EN ISO 11201)	Sound power level L_{Weq} NF EN ISO 3744	Uncertainty K (Sound power level L_{Weq} NF EN ISO 3744)
CS1 P13 HONDA Cyclonic 70184624214	89 dB(A)	2.5 dB(A)	105 dB(A)	4 dB(A)
CS1 P13 HONDA Cyclonic Ø500 70184629389				

- Values determined using the procedure described in the standard **EN 13862**.
- The measurements are made with new machines. Actual values may vary with site conditions, in terms of:
 - Wear Machine
 - Lack of maintenance
 - Inappropriate tool for application
 - Tool in poor condition
 - Unskilled operator
 - Etc...
- Measured values relate to an operator in normal use, as described in the manual position.

3 ASSEMBLY AND COMMISSIONING

Before beginning the work with the CS1, you have to assemble some parts.

3.1 *Tool assembly*

Only use NORTON blades with the CS1.

A blade with a maximum diameter of 500 mm can be fitted. All tools used must be selected with regard to their maximum permitted cutting speed for the machine's maximum permitted rotation speed.

Before mounting a new blade, switch the machine off.

To mount a new blade, follow these steps:

- Turn the wheel until the cutting head is in the raised position.
- Loosen the screw maintaining the blade guard with the 19mm wrench, and turn it open.
- Loosen the hexagonal nut, which holds the removable outer flange with the 36mm wrench.
- Remove the outer flange.
- Clean the flanges and blade shaft and inspect for wear.
- Mount the blade on the shaft ensuring that direction of rotation is correct. Wrong direction of rotation blunts the blade quickly.
- Replace outer blade flange.
- Tighten hexagonal nut with spanner supplied for this purpose.
- Close the blade guard.

The blade bore must correspond exactly to the blade shaft. Cracked or damaged bore is dangerous for the operator and for the machine.

3.2 *Water cooling system*

Fill the water tank with clean water.

Open water-tap (note that handle on water-tap should be in line with water-flow).

Ensure that water is flowing freely in the circuit and delivered adequately to both sides of the blade, as insufficient water supply may result in premature failure of the diamond blade.

In case of frost, empty the water cooling system.

3.3 Starting the machine

Make sure the blade is raised clear up the ground before starting the machine.

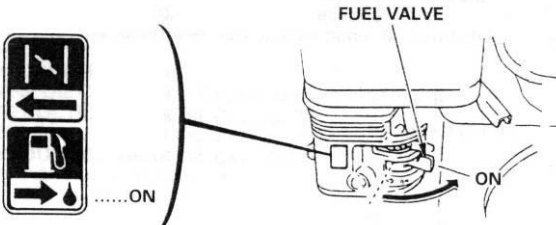
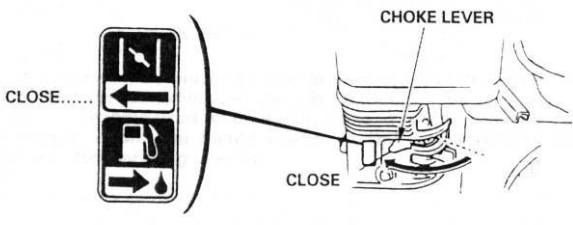
	
<p>Turn the fuel valve to the ON position.</p>	<p>Move the choke lever to the CLOSED position. NOTE: do not use the choke if the engine is warm or the air temperature is high.</p>

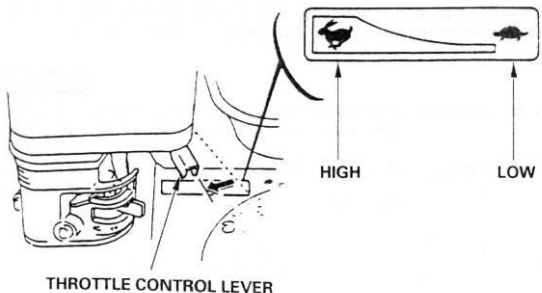
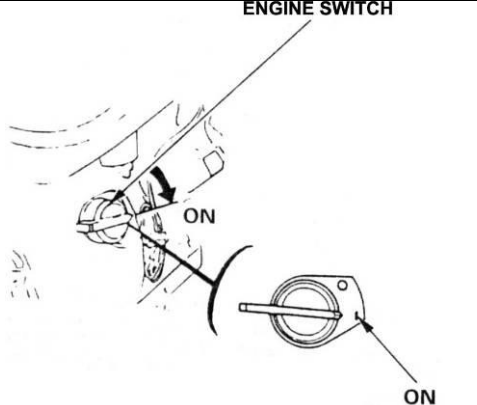
	
<p>Move the throttle control lever slightly to the left.</p>	<p>Put the engine switch on ON, and make sure the emergency switch on the board of the machine is in the correct position.</p>

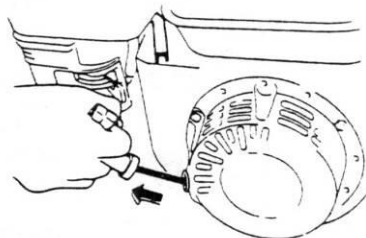
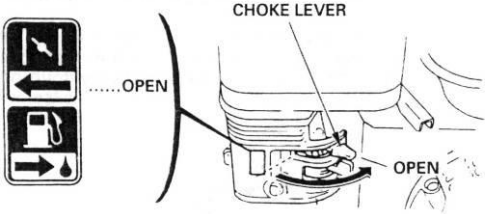
	
<p>Pull the starter grip lightly until you feel resistance, then pull briskly. CAUTION: Do not allow the starter grip to snap back against the engine. Return it gently to prevent damage to the starter.</p>	<p>As the engine warms up, gradually move the choke lever to the OPEN position. Position the throttle control lever for the maximum engine speed.</p>

To stop the engine, move the throttle control lever fully to the right, then turn the engine switch to the OFF position. Turn the fuel valve to the OFF position.

4 TRANSPORT AND STORING

Take the following measures in order to transport and store the CS1 securely.

4.1 *Securing for transport*

Before transporting the machine:

- Remove the blade.
- Empty the water tank.
- Raise the guide-a-cut in its upright position.
- Raise the cutting frame to its highest position using the handwheel.

4.2 *Transport procedure*

The machine can be moved on a flat surface using its wheels. Use the metal hook located on the board of the machine over the motor to move the machine with a crane.

4.3 *Long period of inactivity*

If the machine is not going to be used for a long period, please take the following measures:

- Completely clean the machine.
- Loosen the drive belts.
- Grease the threaded shaft.
- Possibly change the motor oil.
- Empty the water system.

The storage site must be clean, dry and at a constant temperature.

5 OPERATING THE CS1

5.1 *Site of work*

Before you start working, please check the following points:

- Remove from the site anything, which might hinder the working procedure.
- Make sure the site is sufficiently well lit.
- Make sure you have a continual adequate view of the working area so you can intervene in the working process at any time.
- Keep other staff out of the area, so you can work securely.

5.2 *Cutting method*

In this section, you can find instructions to make a straight cut at the desired depth.

5.2.1 Preparing your cut

Before starting the machine,

- Draw a line on the floor over the cutting length.
- Make sure you have filled the engine tank with fuel, and the water tank with water. No petrol is supplied with the machine.
- The engine is shipped with oil. Check oil level before starting. Top up if required.
- Make sure you have mounted the correct blade as recommended by the manufacturer depending on the material to be worked, the working procedure (dry or wet cut) to be carried out, and the efficiency required.
- Make sure that the flanges securely hold the diamond blade.
- Make sure that the blade is not touching the floor before starting.
- Roll the machine until the blade is over the line.
- Lower the guide-a-cut so it touches the line.

5.2.2 Cutting the floor

You can now start the engine.

To make your cut,

- Turn the depth hand wheel until the blade slightly touches the floor.
- Open water valve to control the amount of water required for the type of blade, using 15 to 25l/min for wet and 1-2l/min for dry cutting, dust control. Check for minimum water level regularly.
- turn the hand wheel to lower blade into the cut.
- Once the required depth of cut is reached, push the machine forward with steady and gentle pressure and follow the line with the pointer. The feed speed must be adjusted depending on the material being cut, and depth of cut.
- At the finish of the cut, raise the blade out of the cut by turning the hand wheel, switch off the engine and shut-off the water.

6 MAINTENANCE AND SERVICE

ATTENTION : to perform maintenance on the machine, always switch it off. Always wear a face mask and safety goggles while performing the maintenance of machine.

6.1 Maintenance of the machine

To ensure a long-term quality from the cutting with the CS1, please follow the maintenance plan below:

		Regular service period Perform at every indicated period →						
		After one hour of work	Begin of the day	During the changing of the tool	End of the day	Every week	After a fault	After a damage
Whole machine	Visual control (general aspect, watertightness)							
	Clean							
Flange and blade fixing devices	Clean							
Belts tension	Control							
Water hoses and nozzles	Clean							
Depth screw	Grease							
Engine housing	Clean							
Reachable nuts and screws	Tighten up							

Adjustment and replacement of the belts

After one hour of work, the belts heat and stretch. Therefore, you have to re-tension them.

To adjust the belts, firstly remove the belt guard by unscrewing the 2 nuts. Loose the 2 bolts at the back of the engine-plate and shift the engine by using the screw on the back of the plate to retighten the belts.

To replace the belts, move the engine completely down by unscrewing the screw at the back of the engine-plate. Adjust the belts and retighten them using the screw at the back of the engine plate.

Always use a matched set of belts. Do not replace single belts. After controlling or retightening the belts, reassemble the belt guard on the frame of the machine.

Lubrication

The CS1 uses life-lubricated bearings. Therefore, you don't need to lubricate them at all.

Grease the depth screw every day.

Cleaning of the machine

Your machine will last longer if you clean it thoroughly after each day of work.

6.2 Maintenance of the engine

		Each use	First month or 20 hours	Every 3 months or 50 hours	Every 6 months or 100 hours
<p>Regular service period Perform at every indicated month or operating hour interval, whichever comes first</p> <p style="text-align: right;">→</p>					
Engine oil	Check level				
	Change				
Air cleaner filter	Check				
	Clean				
Fuel strainer cup	Clean				
Spark plug	Check-Clean				
Fuel line	Check (Replace if necessary)	Every 2 years			

Engine oil

To change the oil,

- Remove the oil filler cap/dipstick and drain bolt.
- Allow the oil to drain completely.
- Dispose of used motor oil in a manner that is compatible with the environment. We suggest you to take used oil in a sealed container to your local recycling centre or service station for reclamation. Do not throw it in the trash, pour it on the ground or down in a drain.
- Reinstall the drain bolt, and tighten it to 18 N.m.
- Fill the crankcase with the engine oil to the outer edge of the oil filler neck.
- Reinstall the filler cap/dipstick.

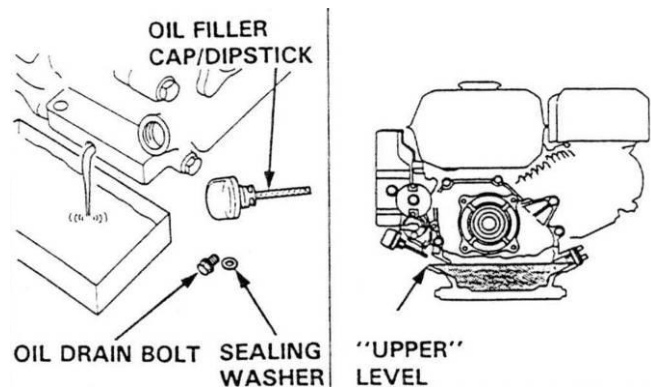

Air cleaner

The CS1 has a dual type filter.

To service the air cleaner filter, follow these instructions:

- Remove the nut, air cleaner cover and wing nut.
- Remove the pre air cleaner elements and separate them.
- Carefully check both elements for holes or tears and replace if damaged.
- **Paper element:** tap element lightly several times on a hard surface to remove excess dirt or blow compressed air lightly through the filter from the inside out. Never brush the dirt off; brushing will force dirt into the fibres.
- **Foam element:** clean in warm soapy water, rinse and allow to dry thoroughly. Dip the element in clean engine oil and squeeze out all the excess. The engine will smoke during initial start-up if too much oil is left in the foam.
- Shine a light through the elements, and inspect them carefully. Reinstall the elements if they are free of holes and tears.

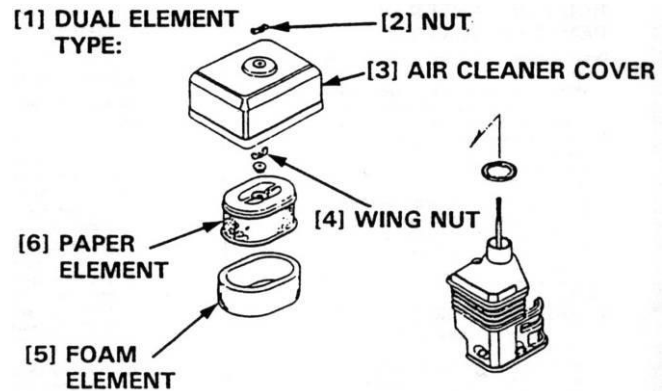

Fuel strainer cup

To service fuel strainer cup, follow these instructions:

- Turn off the fuel valve and remove the strainer cup.
- Clean the strainer cup with solvent.
- Install the O-ring and strainer cup.
- Tighten the strainer cup to 4N.m.

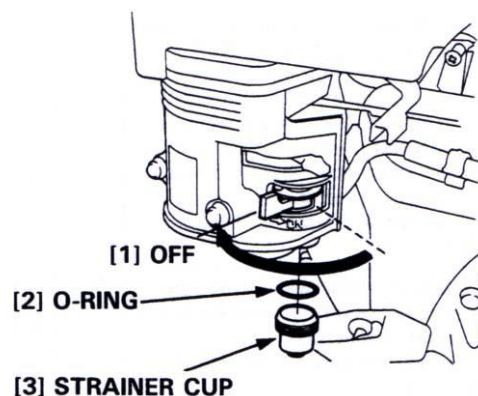

Spark plug

To service the spark plug, follow these instructions:

- Visually inspect the spark plug. Discard the plug if the insulator is cracked or chipped.
- Remove carbon or other deposits with a stiff wire brush.
- Measure the plug gap with a wire-type feeler gauge. If necessary, adjust the gap by bending the side electrode.
- Make sure the sealing washer is in good condition; replace the plug if necessary.
- Install the plug fingertight to seat the washer, then tighten with a plug wrench (an additional $\frac{1}{2}$ turn if a new plug) to compress the sealing washer. If you are reusing a plug, tighten $\frac{1}{8}$ - $\frac{1}{4}$ turn after the plug seats.

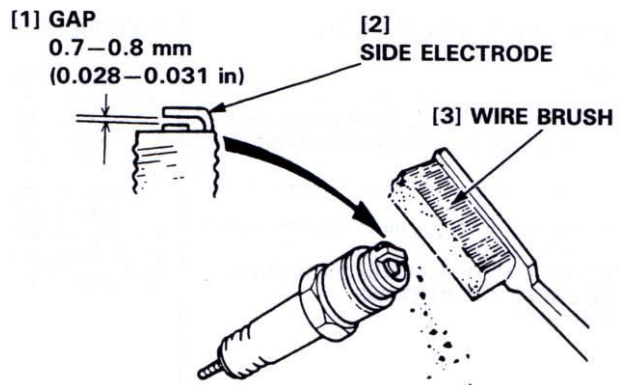

Fuel line

To service the fuel line, follow these instructions:

- Drain the fuel into a suitable container, and remove the fuel tank.
- Disconnect the fuel line, and unscrew the fuel filter from the tank.
- Clean the filter with solvent, and check, that the filter screen is undamaged.
- Place the O-ring on the filter and reinstall. Tighten the filter to 2N.m. After reassembly, check for fuel leaks.

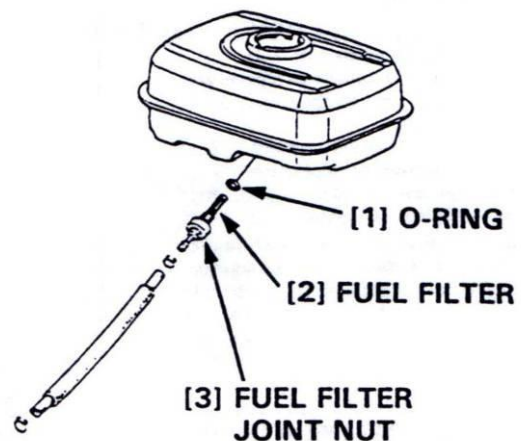

Further maintenance

For further maintenance, please contact the nearest engine maintenance centre.

7 FAULTS: CAUSES AND CURES

7.1 *Fault-finding procedures*

Should any fault occur during the use of the machine, turn it off. Let only qualified staff make any intervention other than the one described in the previous section.

7.2 *Trouble-shooting guide*

Trouble	Possible source	Resolution
Hard starting	Not enough fuel	Fill fuel tank
	Fuel filter clogged	Clean fuel filter
	Spark plug faulty	Inspect spark plug
	Stronger fault	Contact nearest engine maintenance centre
Engine lacks power	Air filter restricted	Clean or replace air filter
	Stronger fault	Contact nearest engine maintenance centre

7.3 Customer service

When ordering spare parts, please mention:

- The serial number (7 digits).
- The code of the part.
- The exact denomination.
- The number of parts required.
- The delivery address.
- Please indicate clearly the means of transportation required such as "express" or "by air". Without specific instructions, we will forward the parts through the means which seem appropriate to us and but which is not always the quickest way.

Clear instructions will avoid problems and faulty deliveries.

If not sure, please send us the defective part.

In the case of a warranty is claim, the part must always be returned for evaluation.

Spare parts for the engine can be ordered with the manufacturer of the engine or with their dealer, which is often quicker and cheaper.

This machine has been manufactured by Saint-Gobain Abrasives S.A.

190, Bd. J.F.Kennedy

L- 4930 BASCHARAGE

Grand-Duché de Luxembourg.

Tel. : 00352-50401-1

Fax : 00352- 50 16 33

<http://www.construction.norton.eu>

Guarantee can be claimed and technical support obtained from your local distributor where machines, spare parts and consumables can be ordered as well:

SAINT-GOBAIN ABRASIVES
INDUSTRIEWEG 21
9420 ERPE-MERE
BELGIUM
TEL: +32(0) 2 267 21 00

SAINT-GOBAIN ABRASIVES, S.R.O.
POČERNICKÁ 272/96, MALEŠICE
108 00 PRAHA 10
CZECH REPUBLIC
TEL: +420 255 719 326
FAX: +420 255 719 321

SAINT-GOBAIN ABRASIVES A/S
DYBENDALSVÆNGET 2,
DK-2630 TAASTRUP
DENMARK
TEL: +45 4675 5244

PO BOX 643706
FORTUNE TOWER OFFICE 2106
JLT BLOCK C
(NEXT TO METRO STATION)
JUMEIRA LAKE TOWER, DUBAI
UNITED ARAB EMIRATES
TEL: +971 4 431 5154
FAX: +971 4 431 5434

SAINT-GOBAIN ABRASIFS
RUE DE L'AMBASSADEUR - B.P.8
78 702 CONFLANS CEDEX
FRANCE
TEL: +33 (0)1 34 90 40 00
FAX: +33 (0)1 39 19 89 56

SAINT-GOBAIN ABRASIVES GMBH
BIRKENSTRASSE 45-49
D-50389 WESSELING
GERMANY
TEL: +49(0)2236703-1
+49(0)22368996-0
+49 (0)2236 8911-0
FAX: +49(0)2236703-367
+49(0)22368996-10
+49 (0) 2236 8911-30

FÜR DEN FACHHANDEL
ÖSTERREICH
TEL: +43 (00) 662 430 076

SAINT-GOBAIN ABRASIVES KFT.
1225 BUDAPEST
BÁNYALÉG U. 60/B.
HUNGARY
TEL: +36 1 371 22 50
FAX: +36 1 371 22 55

SAINT-GOBAIN ABRASIVI S.P.A
VIA PER CESANO BOSCONI 4
I-20094 CORSICO MILANO
ITALY
TEL: +39 02 44 851
FAX: +39 02 44 78 266

SAINT-GOBAIN ABRASIVES S.A.
190 RUE J.F. KENNEDY
L-4930 BASCHARAGE
GRAND DUCHE DE LUXEMBOURG
TEL: +352 50 401 1
FAX: +331 83 717 792
NO. VERT (FRANCE): 0800 906 903

SAINT-GOBAIN ABRASIFS, S.A.
2 ALLÉE DES FIGUIERS
AIN SEBAÂ - CASABLANCA
MOROCCO
TEL: +212 5 22 66 57 31
FAX: +212 5 22 35 09 65

SAINT-GOBAIN ABRASIVES BV
GROENLOSEWEG 28
7151 HW EIBERGEN
P.O. BOX 10
7150 AA EIBERGEN
THE NETHERLANDS
TEL: +31 545 466466
FAX: +31 545 474605

SAINT-GOBAIN ABRASIVES AS
KARIHAUGVEIEN, 89
0186 OSLO
NORWAY
TEL: +47 63 87 06 00
FAX: +47 63 87 06 01

SAINT-GOBAIN HPM POLSKA SP. Z O.O.
UL. NORTON 1, 62-600 KOŁO
62-600 KOŁO
POLAND
TEL: +48 63 26 17 100
FAX: +48 63 27 20 401

SAINT-GOBAIN ABRASIVOS, L. DA
ZONA INDUSTRIAL DA MAIA
I-SECTOR VIII, NO. 122
APARTADO 6050
4476 - 908 MAIA
PORTUGAL
TEL: +351 229 437 940
FAX: +351 229 437 949

SAINT-GOBAIN GLASS
BUSINESS UNIT ABRASIVI
PUNCT DE LUCRU : LOC.VETIS, JUD.
SATU MARE 447355
STR. CAREIULUI 11
PARC INDUSTRIAL RENOVATIO
ROMANIA
TEL: +40 261 839 709
FAX: +40 261 839 710

SG HPM RUS
58, F. ENGELS STR.
STROENIE 2
105082 MOSCOW
RUSSIA
TEL: +74 955 408 355
FAX: +74 959 373 224

SAINT-GOBAIN
ABRASIVES (PTY) LTD
2 MONTEER ROAD
ISANDO 1600
P.O. BOX 67
SOUTH AFRICA
TEL: +27 11 961 2000
FAX: +27 11 961 2184/5

SAINT-GOBAIN ABRASIVOS, S.A.
CTRA. DE GUIPÚZCOA, KM. 7,5
E-31195 BERRIOPLANO (NAVARRA)
SPAIN
TEL: +34 948 306 000
FAX: +34 948 306 042

SAINT GOBAIN ABRASIVES AB
GÅRDSFOGDEVÄGEN 18A
168 66 BROMMA • SVERIGE
SWEDEN
TEL: +46 8 580 881 00
FAX: +46 8 580 881 30

SAINT-GOBAIN INOVATIF MALZEMELER VE
ASINDIRICI SAN. TIC. AS.
ALTAYÇEŞME MAH. ÇAMLI SOK. NO:21 ESAS
OFISPAK KAT:9 34843
MALTEPE, İSTANBUL • TURKEY
TEL: 0090-216-217 12 50
FAX: 0090-216-442 40 74

SAINT-GOBAIN ABRASIVES LTD.
UNICORN HOUSE UNIT 1, AMISON CLOSE
REDHILL BUSINESS PARK
STAFFORD ST161WB
UNITED KINGDOM
TEL: +44 1785 279 553
FAX: +44 1785 213 487



Saint-Gobain Abrasifs
190 Rue J.F. Kennedy
L-4930 Bascharage
Grand Duche de Luxembourg
Tel: +352 50 4011
Fax: +331 83717792
no. vert (France) 0800 906 903

www.nortonabrasives.com/fr-fr