

CS900

OPERATING INSTRUCTIONS





SAINT-GOBAIN
Declaration of conformity

The undersigned manufacturer:

SAINT - GOBAIN ABRASIVES S.A.
190, BD J.F. KENNEDY
L- 4930 BASCHARAGE

Declares that this product:

Floor saw: **CS 900**

Code: **70184601342**

is in conformity with the following Directives:

- **"MACHINES" 2006/42/CE**
- **"LOW VOLTAGE" 2014/35/UE**
- **"ELECTROMAGNETIC COMPATIBILITY" 2014/30/UE**
- **"NOISE" 2000/14/CE**

and European standard :

- ***EN ISO 13857 – Safety of machines – Safety Distance***
- ***EN 60204-1 – Safety of machines – Electrical equipment***
- ***EN 61000-3-2 –electromagnetic compatibility***
- ***EN 61000-3-3 – electromagnetic compatibility***
- ***EN 55014 – electromagnetic compatibility***

Valid for machines as of serial number: **1601XXXXX**

Storage site for the technical documents : Saint-Gobain Abrasives 190, Bd. J. F. Kennedy 4930 BASCHARAGE, LUXEMBOURG

This declaration of conformity loses its validity when the product is converted or modified without agreement.

Bascharage, Luxembourg, 12.07.2017.

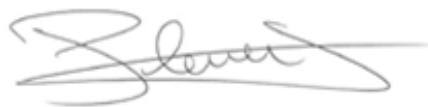

Olivier Plenert, executive officer.

CS900

1	Safety	6
1.1	Safety Message/Alert Symbols	6
1.2	Rules for Safe Operation	7
1.3	Operation & Safety Decals	10
1.4	Safety Decal Locations	11
1.5	Console Controls	13
1.6	Console Control Descriptions	14
2	PRODUCT SPECIFICATIONS	16
2.1	Engine Specifications	Error! Bookmark not defined.
2.2	Saw Features	Error! Bookmark not defined.
2.3	Saw Dimensions	Error! Bookmark not defined.
2.4	Model specification	Error! Bookmark not defined.
2.5	Instructions for Changing Blade Speed	16
3	INSPECTION & START-UP	18
3.1	Belt and Powerband Inspection	18
3.2	Pre-Operation Checklist, Schedule Maintenance Quick Reference	19
4	OPERATION	21
4.1	Blade Mounting Instructions	21
4.2	Starting Engine, Starting Instructions	22
4.3	Saw Guide Alignment and Adjustment, Pointer Alignment	24
4.4	Maneuvering the Saw, Dry Cutting, Wet Cutting, Speed Control-Lever Use and Adjustment	25
4.5	Engaging the Drive Unit, Water Hook Up	26
4.6	Depth Indicator and Depth Stop	Error! Bookmark not defined.
4.7	Zerk Fittings	Error! Bookmark not defined.
5	MAINTENANCE	28
5.1	Engine, Air Cleaner, Arbor, Axle, Drive Unit, & Hydrostatic Drive Unit	28
5.2	Maintenance Schedule	30
5.3	Troubleshooting	36
6	INFORMATIONS RELATIVES AU SERVICE APRES-VENTE GENERAL PRODUCT INFORMATION	10
6.1	Step Cutting	10
6.2	Customer Service	11

1 SAFETY

Safety precautions should be followed at all times when operating this equipment. Failure to read and understand the Safety Precaution and Operating Instructions could result in injury to yourself and others.

This Operation and Parts Manual has been developed to provide complete instructions for the safe and efficient operation of the Norton Clipper Large Road Saw.

Before using this machine, ensure that the person operating the machine has read and understands all instructions in this manual.

1.1 Safety Message/Alert Symbols

A safety message alerts you to potential hazards that could hurt you or others. Each safety message is preceded by a safety alert symbol () and one of three words: **DANGER**, **WARNING**, or **CAUTION**.

DANGER

You **WILL** be **KILLED** or **SERIOUSLY INJURED** if you do not follow directions.

WARNING

You **CAN** be **KILLED** or **SERIOUSLY INJURED** if you do not follow directions.

CAUTION

You **CAN** be **INJURED** if you do not follow directions. It may also be used to alert against unsafe practices.

Each message tells you what the hazard is, what can happen, and what you can do to avoid or reduce injury. Other important messages are preceded by the word **NOTICE**.

NOTICE

You can cause **PROPERTY DAMAGE** to your machine if you don't follow directions.

The safety labels should be periodically inspected and cleaned by the user to maintain good legibility at a safe viewing distance. If the label is worn, damaged or illegible, it should be replaced.

1.2 Rules for Safe Operation



Failure to follow instructions in this manual may lead to serious injury or even death! This equipment is to be operated by trained and qualified personnel only! This equipment is for industrial use only.

The following safety guidelines should always be used when operating the Norton Clipper Large Road Saw.

MAINTENANCE SAFETY

- **NEVER** lubricate components or attempt service on a running machine.
- Keep the machinery in proper running condition. Clean the machine after each day's use. Follow instructions for changing accessories. Inspect tool periodically and, if damaged, have repaired by authorized service facility.

SET UP & TRANSPORTATION SAFETY

- **ALWAYS** use caution and follow the instructions when lifting and transporting this machine.
- **ALWAYS** tie down the machine when transporting. **DO NOT** tow this machine behind a vehicle.
- **NEVER** transport with the blade mounted on the machine.
- Lift only from the lift bail.

GENERAL SAFETY



- **DO NOT** operate or service this equipment before reading this entire manual. Read and understand all warnings, instructions and controls on the machine.

This equipment should not be operated by persons under 18 years of age.



NEVER operate this equipment without proper protective clothing, shatterproof glasses, steel-toed boots and other protective devices required by the job.

- **NEVER** operate this equipment when not feeling well due to fatigue, illness or taking medicine.
- **NEVER** operate this equipment under the influence of drugs or alcohol.
- Whenever necessary, replace nameplate, operation and safety decals when they become difficult to read.
- **ALWAYS** check the machine for loose bolts before starting.

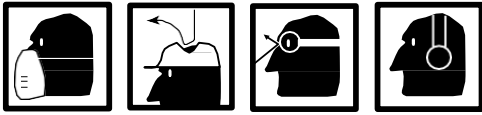

- **ALWAYS** wear proper respiratory, head, ear and eye protection equipment when operating this machine.

- **ALWAYS** store equipment properly when it is not being used. Equipment should be stored in a clean, dry location out of the reach of children.
- **CAUTION** must be observed while servicing the machine. Rotating parts can cause injury if contacted. Have all service performed by competent service personnel.
- Operate this machine only in well ventilated areas. **ALWAYS** ensure that the machine is on level ground before using.



- **NEVER** operate this machine in an explosive atmosphere.

- Establish a training program and give a copy of this manual to operators of this equipment. If you need extra copies, call (254) 918-2310.

SAW BLADE SAFETY

For complete safety information, refer to ANSI Safety Code B7.1 available through the American National Standards Institute.



- **ALWAYS** keep area around the machine clear of obstructions and clear the work area of unnecessary people. Keep all body parts away from the blade and all other moving parts.



- Before starting the machine, check that all guards are in position and correctly fitted. **NEVER** allow blade exposure from the guard to be more than 180 degrees. **DO NOT** operate this machine with any guard removed.

- Inspect the blade, flanges and shafts for damage before installing the blade. **NEVER** use damaged or worn blade flanges.
- The blade shaft flanges must be of proper diameter for the size blade being used.
- Inspect the blade, flanges and size shown for each blade size. **DO NOT** exceed maximum blade speed shown, as excessive speed could result in blade breakage. Use **ONLY** blades marked with a maximum operating speed greater than the blade shaft speed. Verify speed and saw drive configuration by checking blade shaft RPM and pulley diameters and blade flange diameters.
- Use the correct blade for the type of work being done. Use only reinforced abrasive blades or steel center diamond blades and flanges supplied with the saw or manufactured for use on concrete saws.

DO NOT use carbide-tipped blades. Check with the blade manufacturer if you do not know if blade is correct.

- Make sure the blade and flanges are clean and free of dirt and debris before mounting the blade on the saw. Verify the blade arbor hole matches the machine spindle before mounting the blade. **ALWAYS** mount the blade solidly and firmly. Wrench tighten the arbor nut.
 - Make sure the blade is not contacting anything before starting the engine.
 - **ALWAYS** cut in a straight line. **DO NOT** cut deeper than 1" per pass with a dry blade. Step cut to achieve deeper cuts. **NEVER** cock, jam wedge or twist the blade in a cut. **DO NOT** grind on the side of the blade.
- 
- **DO NOT** touch a dry cutting blade immediately after use. These blades require several minutes to cool after each cut. **DO NOT** use a blade that has been overheated (Core bluish color).

FUELING SAFETY



- **ALWAYS** use caution when handling fuel. Shut off the engine and allow to cool before refueling.
- Move the machine at least 10 feet (3 meters) from the fueling point before starting the engine and make sure the gas cap is on the machine and the fuel can is properly tightened.

1.3 Operation & Safety Decals

The Norton Clipper Large Road Saw is equipped with a number of safety decals provided for operator safety and maintenance information. Should any of these decals become unreadable, replacements can be obtained by calling (254) 918-2310.



Decal A

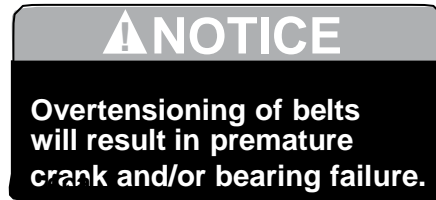

Decal B



Decal C

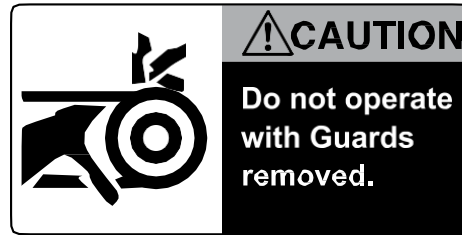

Decal D, E & G



Decal F

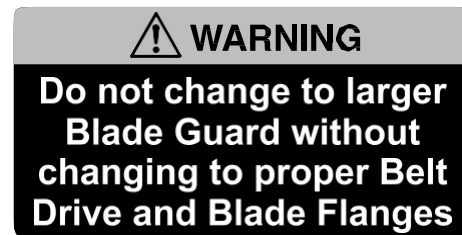

Decal H

⚠ WARNING

Read entire operator's manual before operating this machine. Understand all warnings, instructions and controls. IF YOU DO NOT HAVE AN OPERATOR'S MANUAL, CALL TOLL FREE 1-800-474-5594

Machinery Hazard - Always keep all guards in place and in good condition. Always keep all parts of your body away from blade and all other moving parts. Never allow blade exposure to exceed 180°.

Always use blades with a rated speed above the blade shaft speed. Excessive speed can cause blade breakage. Verify speed by checking blade shaft RPM, pulley diameters and blade flange diameter.

Never use damaged blades or equipment.

Never operate this machine in areas of combustible material.

Some dust created by power sanding, sawing, grinding, drilling, and other construction activities contains chemicals known (to the State of California) to cause cancer, birth defects or other reproductive harm. Some examples of these chemicals are:

- Lead from lead-based paints
- Crystalline silica from bricks and cement and other masonry products
- Arsenic and chromium from chemically-treated lumber

Always wear safety approved hearing, eye, head and respiratory protection

Decal J

⚠ DANGER

Lethal exhaust gases. Use only in wellventilated areas. DO NOT use indoors.

Decal I

Norton Clipper Large Road Saw Decal Sheet, Part No. 246002

1.4 Safety Decal Locations

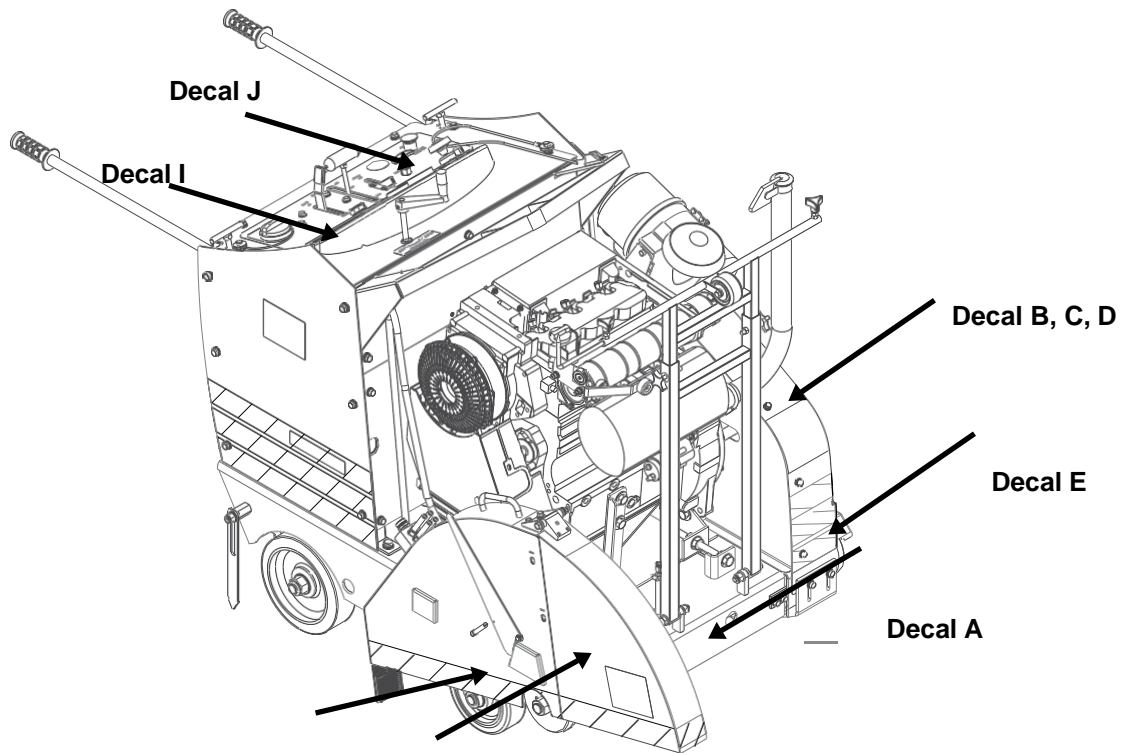

Decal G, H

Decal F

Norton Clipper Large Road Saw Safety Decal Locations

Decal	Location	Description
A	Machine Front	Caution Keep Hands and Feet Clear
B	Top of Belt Guard	Caution Do Not Overtension Belts
C	Top of Belt Guard	Caution Do Not Touch Hot Surface
D	Top of Belt Guard	Caution Do Not Operate with Guard Removed
E	Face of Shaft Guard	Caution Do Not Operate with Guard Removed
F	Top of Blade Guard	Blade Rotation Direction
G	Side of Blade Guard	Caution Do Not Operate with Guard Removed
H	Top of Blade Guard	Warning Do Not Change to Larger Blade Guard
I	Console	Warning Reading the manual, Machinery hazard, protect hearing, seeing, headgear, California Proposition 65 message
J	Console	Danger Lethal exhaust gases

1.5 Console Controls

The following is a list of console controls elements:

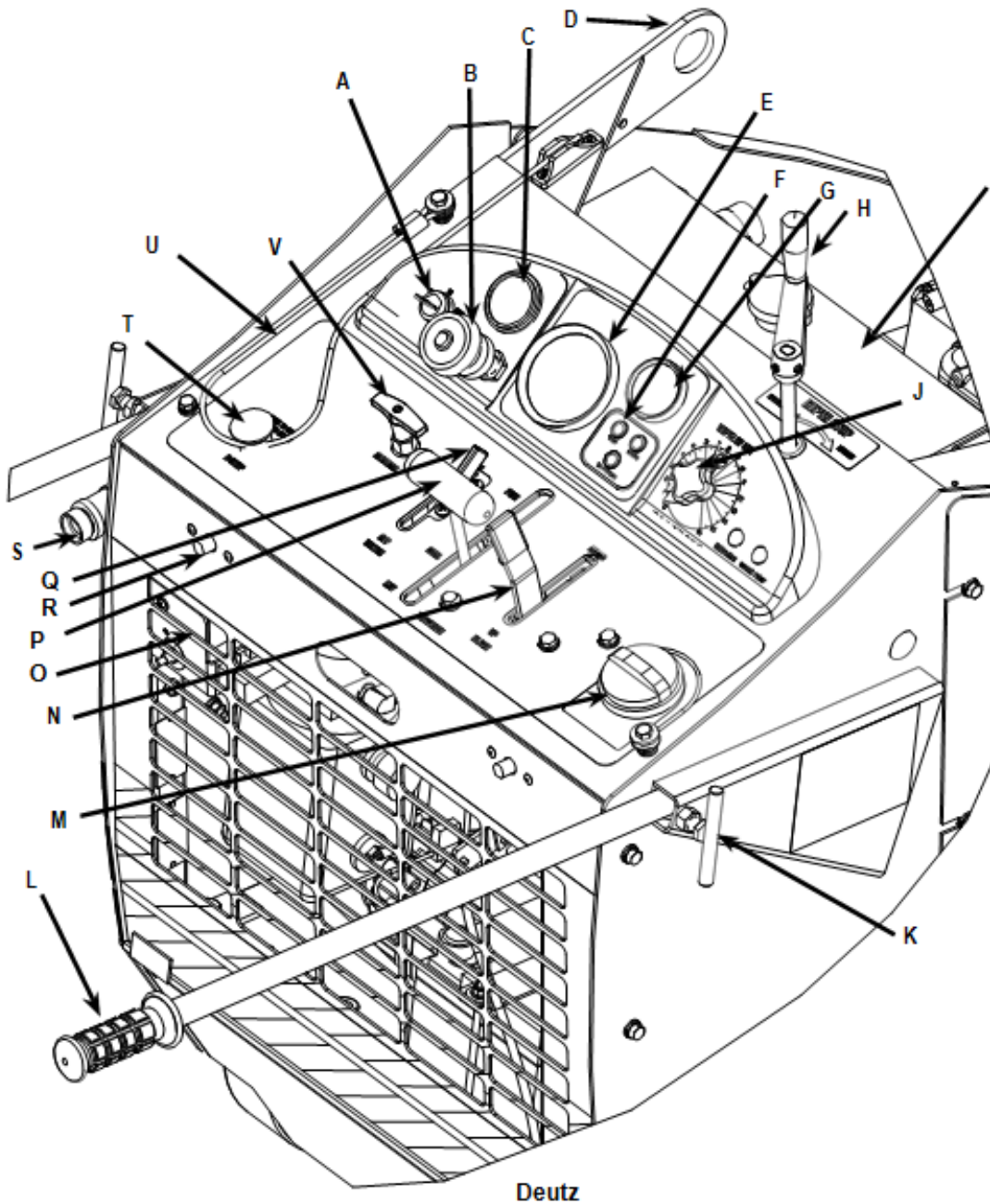

1.6 Console Control Descriptions

Deutz Console

Decal	Name	Function
A	Ignition Switch	Use to start engine (Glow-OFF-ON-START).
B	Engine Throttle	Controls engine speed.
C	Engine Temp Gauge	Shows temperature of engine.
D	Lifting Points	Used to lift saw.
E	Engine Tachometer	Shows the engine RPM's.
F	Indicator Lights	Indication of Oil Pressure, Charge and Glow Plug.
G	Fuel Gauge	Shows the level of fuel in the fuel tank.
H	Depth Stop	Sets the depth stop for repetitive cuts at the same depth.
I	Radiator	Filled with engine coolant
J	Depth Indicator	Displays cutting depth.
K	T-Handle Knob	Use to tighten operator grip handles.
L	Handle Grip	For operator gripping.
M	Fuel Tank Fill	Fill the fuel tank at this location.
N	Raise/Lower Handle	Controls raising and lowering of blade.
O	Temp Gauge Reset	Must be reset after overheat condition
P	FNR Handle	Used to set direction of saw (Forward/Neutral/Reverse).
Q	Water Valve Lever	Controls water flow to blade guard.
R	Back Panel Knob	1/4 Turn Fastener to remove back.
S	Water Inlet	Hook-up for standard water hose.
T	E-Stop	Stops down engine in an emergency!
U	Point Lift Cable	Allows operator to lift pointer.
V	Neutral Engagement Handle	Engages Transmission, Turn-To-Lock.

TECHNICAL SPECIFICATIONS	CS900-20	CS900-26	CS900-30	CS900-36
Blade Guard Capacity – in. (mm)	20" (508)	26" (660)	30" (762)	36" (914)
Maximum Depth of Cut – in. (mm)	8-5/8" (219)	10-5/8" (270)	12-5/8" (321)	14-5/8" (371)
Arbor Size – in. (mm)	1" (25.4)	1" (25.4)	1" (25.4)	1" (25.4)
Blade Flange Diameter – in. (mm)	4" (102)	5" (114)	5" (127)	6" (152)
Blade Shaft RPM	2,560	2,469	2,194	1,340
Blade Shaft Diameter – in. (mm)	2" (50.8)			
Blade Shaft Bearings	Heavy Duty Self Aligning Pillow Base			
Blade Shaft Drive	One ten Groove Powerband			
Blade Guard Attachment	Hinged, All Steel			
Blade Control	Electro-Hydraulic			
Axle – Front – in. (mm)	1" (25.4)			
Axle – Rear – in. (mm)	1-1/4" (32)			
Wheels – Front D x W x B – in. (mm)	8" x 3" x 1" (26 x 76 x 25.4)			
Wheels – Rear D x W x B – in. (mm)	10" x 3" x 1-1/4" (254 x 76 x 31.7)			
Transmission	Eaton hydrostatic transmission with infinite adjustable forward, and reverse with neutral/free-wheel position. Transmission uses heavy duty chain/sprocket and pinion/gear for final speed reduction and is capable of a maximum travel speed of 220 SFPM			
Control	Forward/Reverse Control and Engage/Disengage Levers			
Speed	0-300 SFPM			
Chassis	Heavy duty jig-welded box frame made of 1/4" plate with internal reinforcement gussets.			
Power Source	Diesel Turbo Charged			
Engine Type	Deutz BF3L2011			
Specifications	7482			
Maximum Horsepower	61 HP (45.5kw) – data provided by engine manufacturer			
Displacement – cu. In. (l)	142.2 in. ³ (2,331 cm ³)			
Bore – in. (mm)	3.7" (94)			
Stroke – in. (mm)	4.4" (112)			
Cylinders/Cycle	Three Cylinder Turbo Diesel			
Fuel Capacity – gal. (l)	10 gal. (37.8 l)			
Oil Capacity – qt. (l)	8.45 qt. (8 l)			
Air Filter	Three Stage Sy-Klone			
Starter	Electric			
Engine Cooling	Forced Air/Oil			

SAW DIMENSIONS

Height	55" (1,397)	55" (1,397)	55" (1,397)	55" (1,397)
Minimum Saw Length (Transport) – in. (mm)	58" (1,473)	58" (1,473)	58" (1,473)	58" (1,473)
Maximum Saw Length (Working) – in. (mm)	164" (4,167)	164" (4,167)	164" (4,167)	164" (4,167)
Maximum Pointer Length – in. (mm)	82-1/4" (2,089)	82-1/4" (2,089)	82-1/4" (2,089)	82-1/4" (2,089)
Frame Width – in. (mm)	31-3/8" (797)	31-3/8" (797)	31-3/8" (797)	31-3/8" (797)
Saw Width – in. (mm)	39-3/4" (1,010)	39-3/4" (1,010)	39-3/4" (1,010)	39-3/4" (1,010)
Front (Outside to Outside Wheel Width) – in. (mm)	29-1/2" (749)	29-1/2" (749)	29-1/2" (749)	29-1/2" (749)
Rear (Outside to Outside Wheel Width) – in. (mm)	31" (787)	31" (787)	31" (787)	31" (787)
Blade to Wall – in. (mm)	2-19/32" (66)	2-19/32" (66)	2-19/32" (66)	2-19/32" (66)
Wheel Base Length – in. (mm)	10-1/2" (267)	10-1/2" (267)	10-1/2" (267)	10-1/2" (267)
Blade Shaft Maximum Height	20-1/2" (521)	20-1/2" (521)	20-1/2" (521)	20-1/2" (521)
Weight Crated lbs. – lbs (kg)	1,590 lbs (721 kg)	1,590 lbs (721 kg)	1,590 lbs (721 kg)	1,590 lbs (721 kg)
Weight Uncrated – lbs (kg)	1,540 lbs (700 kg)	1,540 lbs (700 kg)	1,540 lbs (700 kg)	1,540 lbs (700 kg)

ACCESSORIES

Light kit with magnetic base	701846 26513 3
Water pump kit	701846 26502 7

2 PRODUCT SPECIFICATIONS**2.1 Instructions for Changing Blade Speed****WARNING**

Do not exceed blade shaft speed shown for each blade size. Excessive blade speed could result in blade failure and serious personal injury.

**NOTICE**

Changing Blade Guard size **MUST** be accompanied by changing Pulleys to achieve the correct blade speed.

Blade Size	Model # Deutz	Includes	Blade Shaft Speed (Engine RPM = 2800)	Blade Speed (FPM)
20"	CS900-20	18" Blade Guard Assembly 4" Flange Set 3.2" Engine Pulley 4.12" Blade Shaft Pulley 10 Groove Powerband	2200 RPM	14" = 8050 16" = 9200 18" = 10350 20" = 11500
26"	CS900-26	26" Blade Guard Assembly 5" Flange Set 3.2" Engine Pulley 4.8" Blade Shaft Pulley 10 Groove Powerband	1850 RPM	18" = 8700 20" = 9700 22" = 10650 24" = 11600 26" = 12600
30"	CS900-30	30" Blade Guard Assembly 5" Flange Set 3.2" Engine Pulley 5.8" Blade Shaft Pulley 10 Groove Powerband	1550 RPM	24" = 9750 26" = 10550 28" = 11350 30" = 12200
36"	CS900-36	36" Blade Guard Assembly 6" Flange Set 3.2" Engine Pulley 6.8" Blade Shaft Pulley 10 Groove Powerband 36" Frame Corner	1310 RPM	30" = 10300 26" = 11000 28" = 11650 30" = 12350



NOTICE

As shown on the chart, some blade guards accept more than one size blade.

BLADE GUARDS AND BLADE SIZES	
BLADE GUARD	BLADE SIZE THAT CAN BE USED WITH BLADE GUARD
20"	14" up to 20"
26"	20" up to 26"
30"	26" up to 30"
36"	30" up to 36"

3 INSPECTION & START-UP

3.1 Belt and Powerband Inspection

The CS900 is designed with a transmission belt and a 10 rib powerband. The transmission belt and powerband should be inspected, adjusted and/or replaced periodically. Inspect the belt and powerband daily for cracks, fraying, separation and wear.

Powerband Tension

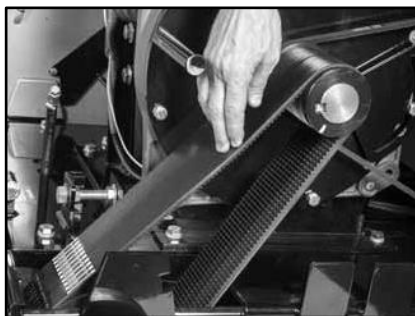

Check powerband tension by applying pressure by pushing down firmly with finger in the middle of the belt; approximately 1/8" deflection is correct.

To Tension Powerband



Loosen 4 bolts that attach the engine mount to frame



Loosen locknut on tension bar



Apply tension to belt by tightening back nut on tension screw.

When correct tension has been obtained, retighten locknut and engine mount bolts. Replace belt guard



A. Lock Nut

B. Breaker arm hole

Check transmission belt tension by applying pressure by pushing down firmly with finger in the middle of the belt. To Tension Belt: Loosen locknut on tension arm. Apply tension with 1/2" drive breaker bar. approximately 3/8" deflection is correct.

Retighten locknut and check deflection is correct. Replace belt guard

3.2 Pre-Operation Checklist, Schedule Maintenance Quick Reference



WARNING

Before leaving our factory, every machine is thoroughly tested. Follow instructions strictly and your machine will give you long service in normal operating conditions.



Before starting up the machine, make sure you read this entire Operation Manual and are familiar with the operation of the machine.

Machine Cold

1. Check engine oil. See Engine Owner's Manual for type and quantity.
2. Connect battery cables.
3. Check hydrostatic transmission fluid level.
4. Test hydraulic operations. Raise and lower.
5. Check the engine air cleaner.

SCHEDULE MAINTENANCE QUICK REFERENCE

1-2 Hour Operation Checklist



WARNING

ALWAYS locate machine on a level surface with the engine “OFF” and the ignition switch set in the “OFF” position before performing any maintenance. Let the machine cool down prior to any service.

1. Check the engine air cleaner hose clamps. Tighten as required.
2. Tension the blade drive V-belts. **DO NOT** overtension.



WARNING

Before performing any maintenance, **ALWAYS** locate machine on a level surface with the engine “OFF” and the ignition switch set in the “OFF” position.

Service Daily

1. Check engine oil level.
2. Check blade guard for damage.
3. Check hoses and clamps for damage or looseness. Tighten or replace as necessary.
4. Check air cleaner for restriction. Replace air filters at regular intervals.

Interval Service

See the Maintenance Schedule Table on Page 23.

4 OPERATION



NOTICE

Before mounting the blade, machine should be turned “OFF”. Clean the blade collars and stub shaft.

4.1 Blade Mounting Instructions

1. Remove Blade Guard.
 - A. Unscrew the hose fitting to disconnect hose.
 - B. Hold the Blade Guard by the handle. Release the inner latch.
 - C. Pull the guard up and off the Saw.



Unscrew Hose Fitting



Hold Blade Guard

2. Remove arbor bolt. If blade is mounted on right side saw, the bolt has left hand threads. To remove turn clockwise. If the blade is mounted on left side of saw, bolt has right hand threads. To remove, turn counter-clockwise.
3. Pull off outer flange
4. Install new blade.
5. Slide in the outer flange in place.
6. Tighten the arbor bolt.
7. Install the blade guard in place. Make sure that the guard locks in place and connect the hose.



Install Blade Guard



WARNING

Observe the rotation arrow on blade and **DO NOT** exceed maximum RPM stamped on the blade. To set proper RPM, consult the Blade Guards and Blade Sizes.

 **NOTICE**

To meet ANSI safety standards, larger diameter blade flanges are required for large diameter blades. Information is available upon request or for complete safety information refer to ANSI Safety Code B7.1

 **NOTICE**

We recommend the use of Norton diamond blades with these saws.

4.2 Starting Engine, Starting Instructions

 **NOTICE**

Read the engine instructions manual before starting.

 **WARNING**

Be sure blade is unobstructed and not resting on ground.

 **WARNING**

Be sure hands and feet are clear of blade.

1. Check engine oil. Add oil if low.
2. Check fuel level. Add fuel if low.
3. Check cooling air intake areas and external surfaces of engine. Make sure surfaces are clean and unobstructed.
4. Check that air cleaner components and all shrouds, equipment covers and guards are in place and securely fastened.

1. Place FNR Handle in **NEUTRAL**.
2. Verify Neutral Engagement Handle is down, in **NEUTRAL**.
3. Pull Engine Throttle Handle out half-way.
4. Start engine by rotating Ignition Switch to the right.

 **NOTICE**

DO NOT crank engine for more than 30 seconds at a time. If engine fails to start, wait about 2 minutes between cranking periods to prevent starter from overheating.

 **NOTICE**

Allow engine to warm up at least 3 minutes before applying load.

5. When engine is warm, throttle may be used out to maximum position.
6. To stop engine, push throttle to idle, rotate ignition switch to “OFF” position.

 **NOTICE**

If the engine has been running hard and is hot, do not shut engine off abruptly. Cool engine by removing load and allowing engine to run idle for 3 to 5 minutes.

4.3 Saw Guide Alignment and Adjustment, Pointer Alignment



WARNING

This operation is performed with the engine "OFF"!

The front and rear pointers are set in line at the factory. However, the pointers should be checked for proper alignment with the blade after every use. The following are the procedures for aligning the pointers with the blade, with the engine shut off.

1. Using a straight edge, carefully mark a line 12 feet long on a smooth level concrete surface.
2. Place the saw parallel to the line. Lower the blade and center it over the line.
3. **FRONT:** With the blade centered over the line and the saw frame parallel to the line, lower the front pointer assembly and position the pointer over the line.
4. **REAR:** With the blade centered over the line and the saw frame parallel to the line, loosen the pointer and adjust up or down and ensure that it touches the line.
5. Finally, roll the saw along the entire length of the line. The saw should lead off no more than 6 inches to the left in 12 feet of forward travel. Adjust the pointer in or out if the lead-off is outside this parameter.
6. Secure hardware.

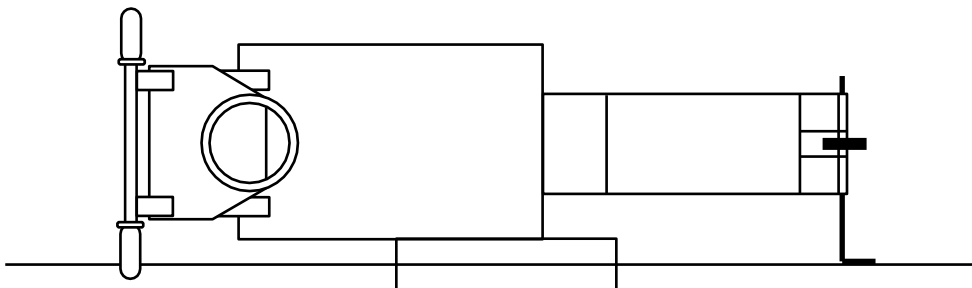

4.4 Maneuvering the Saw, Dry Cutting, Wet Cutting, Speed Control-Lever Use and Adjustment

MANEUVERING THE SAW



WARNING

The blade is spinning whenever the saw is running. Raise the blade as high as possible when maneuvering so that the blade will not strike the pavement.

DRY CUTTING

Dry cutting blades have been specially designed for use with concrete saws. Ensure that the blade you are using is clearly marked for dry cutting.

When dry cutting, it is important to keep the air filter clean. Check the condition of the filter at least every four (4) hours of operation. Clean the pre-filter (wash in soapy water and re-oil) and change the paper filters as soon as it becomes clogged. Concrete dust is very abrasive and will quickly damage internal engine parts, causing loss of compression and eventual engine failure.

Saw only as deep as the specifications and job conditions require. Remember airflow helps to cool the blade during dry cutting. Cutting too deep with one pass, or exerting excessive forward or side pressure can be dangerous. Step cut in increments of 1 inch (25 mm) or less, for the best results.

If reinforced abrasive blades are used for cured concrete, it is usually better to saw only 1 inch deep per pass. If deeper cuts are required, cut in multiple passes.

Thinner Diamond Blades are especially advantageous when cutting dry.

WET CUTTING

The water used on the blade is to provide coolant during cutting and to flush the concrete cutting from the cut. Turn the water control to full "ON" when using wet cutting blades. The required flow rate is 5 to 8 gallons per minute.

FNR HANDLE

The FNR Handle moves the saw forward by pushing the lever away from the operator and moves the saw in reverse by pulling the lever toward the operator. The further you push this lever, the faster the saw travels.



WARNING

Before starting the engine, place this lever in **NEUTRAL**.

RAISE/LOWER HANDLE

The raise/lower handle controls the depth of the blade. When pulled back, the electric/hydraulic pump will raise the blade out of the cut. When pushed forward the blade will lower. The lowering speed is faster, the farther forward the lever is pressed.

4.5 Engaging the Drive Unit, Water Hook Up

This saw is driven by a hydrostatic transmission. To engage the transmission, **PULL** the Neutral Engagement Handle up and turn to either direction to lock.

 **NOTICE**

DO NOT engage the unit unless FNR Handle is on **NEUTRAL**.

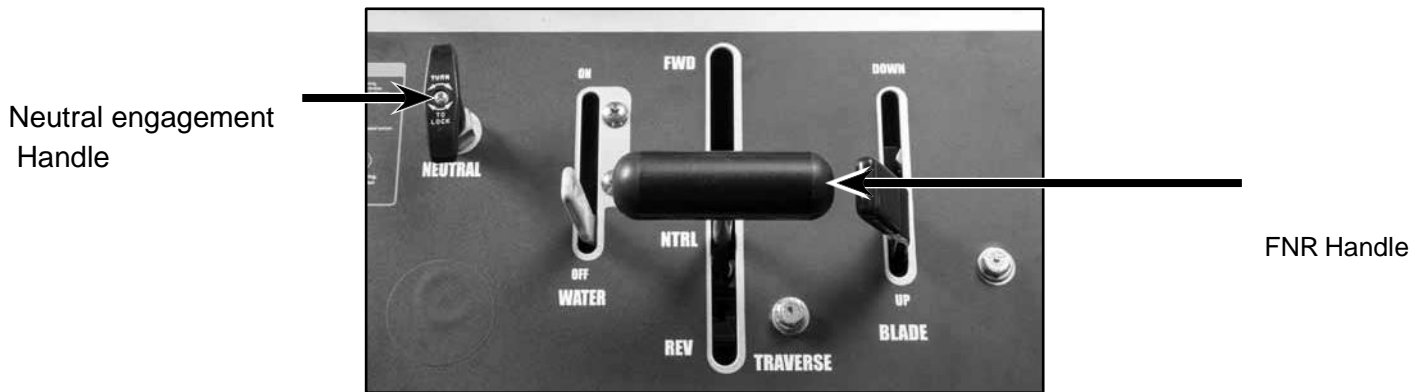

To disengage the transmission, twist the Neutral Engagement Handle to unlock, and **PUSH** down.

WATER HOOK UP

Prior to starting the engine, you should hook up the water hose to the Water Inlet and visually inspect it to make sure that water is flowing to the blade. Hook up the hose to the unit and turn on the water source. Open the water valve.



NOTICE

Water flow volume can be metered by opening the water valve partially.

Next, lift the front of the blade guard and visually inspect to make sure water is flowing out of each of the tubes. If any of the holes are blocked, flush impurities from the tube.

Water Valve



Water Hook Up

5 MAINTENANCE

5.1 Engine, Air Cleaner, Arbor, Axle, Drive Unit, & Hydrostatic Drive Unit

DEPTH INDICATOR AND DEPTH STOP

The saw is equipped with a Depth Indicator and a Depth Stop. The Depth Indicator tells you approximately how deep you are in the cut. To set the indicator, you need to first lower the blade until it is just touching the ground and then rotate the Depth Indicator knob to 0.

The Depth Stop is used for several cuts at the same depth. It is set by finding the desired depth and then turning the knob until it is tight. This will prevent cutting below the “locked” level to provide a consistent depth with every cut.

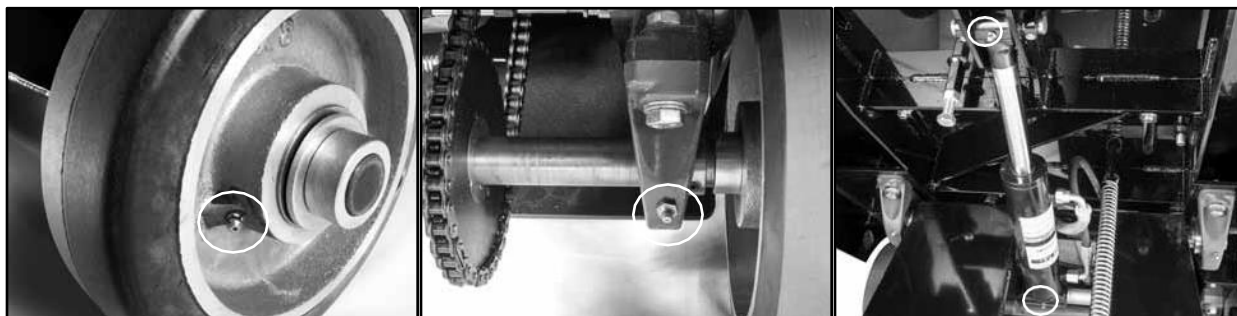
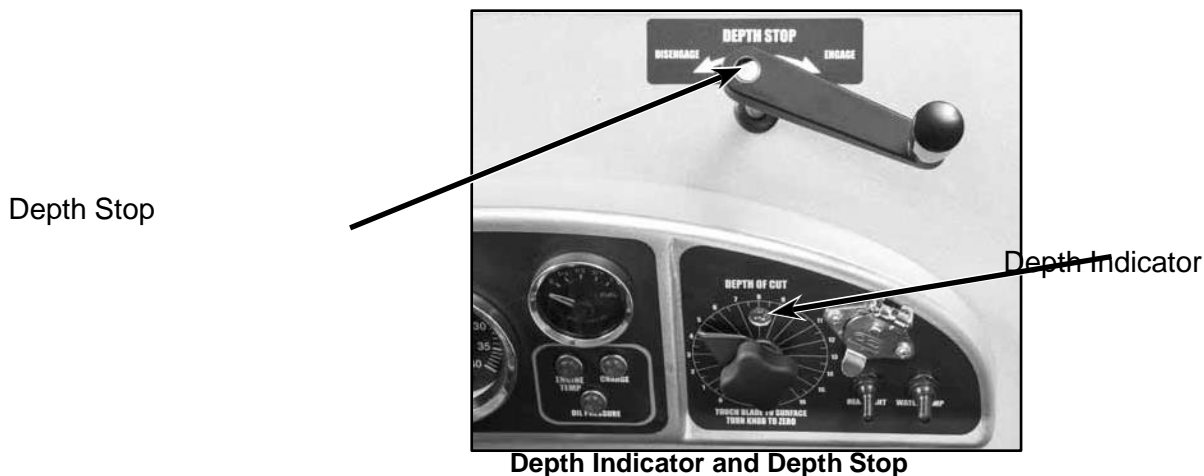

Two zerk fittings on front truck wheels

Four zerk fittings on the bearings

Two zerk fittings on the raise cylinder

ENGINE

The operation and life of the engine depends on proper maintenance. Do not start engine until engine pre-check is complete. The engine pre-check consists of checking the oil, fuel level, air filter and greasing the wheel, axle, drive unit and arbor bearings. Basic engine maintenance is shown in Maintenance Schedule Table on the next page. For more detailed information, please refer to the Engine Operator Maintenance Manual and Warranty provided with the saw.

! NOTICE

When breaking-in a new saw, we recommend running the engine for one hour with no load prior to actual use on the job.

AIR CLEANER

Due to the dusty conditions created by sawing, it is essential to check the engine air cleaner element daily. Remove the element and shake out the accumulated dust and dirt. Wipe out dirt from the inside cover and from the housing. Check the engine manual for washing instructions. Stocking replacement filters is strongly recommended.

ARBOR, AXLE, DRIVE UNIT AND WHEEL BEARINGS

Blades shaft, Axle, Drive Unit, and Wheel Bearings should be greased according to the Maintenance Schedule table on the next page.

! WARNING

DO NOT inspect when the engine is running.

Use of high quality detergent oil of API (American Petroleum Institute) service class SF or SG. Select the viscosity based on the air temperature at the time of operation. For temperatures below 0°F, 5W-20 or 5W-30 oil is recommended. For temperatures above 0°, 10W-30 or 10W-40 oil is recommended. Check your engine manual for other recommendations.

HYDROSTATIC DRIVE UNIT & TRANSMISSION GEARBOX

The fluid shipped in your hydrostatic transmission is a fluid having a viscosity equivalent to SAE 20W20. Mobil fluid 300 or any other oil equivalent to SAE 20W20 is preferred by Eaton Transmission. The expansion tank (Marker A) is marked for proper fluid level. It should be checked when unit is cold. **DO NOT** allow the unit to run low on oil. If the unit is low, you can add oil by removing the cap (Marker B). Remove plug (Marker C) and fill transmission gearbox with 80-90 SAE Gear Oil to lower edge of fill hole.

B A

Expansion Tank and Cap

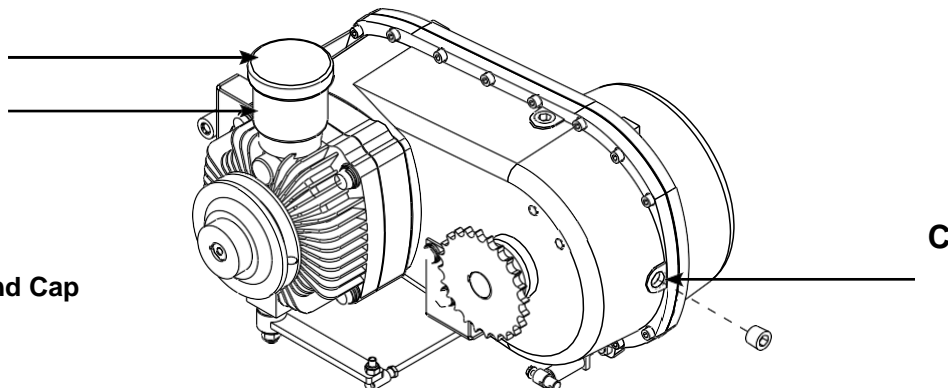

5.2 Maintenance Schedule

Regular service period Perform at every indicated period		After one hour of work	Beginning of the day	During the changing of the tool	End of the day	Every week	Every month	After a fault	Every year
Whole machine	Visual control(general aspect, water-tightness)								
	Clean								
Oil (hydrostatic)	Control and refill								
Flange and blade fixing devices	Clean								
Belts tension	Control								
Water hoses and nozzles	Clean								
Hydraulic hose and connectors	Control tightness								
Engine housing	Clean								
Reachable nuts and screws	Tighten up								
Reversing gear box	Change oil								
Hydrostatic feed movement	Change oil								
Grease zerk fittings	Grease								
Grease zerk	Grease								

Regular service period Perform operating hour interval		Each use	First month or 25 hours	Every 250 hours	Every 500 hours	Every 1000 hours
Engine oil	Check level (5)					
	Change (4)					
Oil filter	Change (2)					
Fuel filter	Change (3)					
Cooling air zone	Check-Clean					
Air cleaner filter	Clean (dry cut)					
	Clean (wet cut)					
	Change the cartridge					
Valve clearance (1)	Check and adjust (only to be done by a DEUTZ-specialist)					
Fuel filter	Replace					
Belt for alternator	Check					

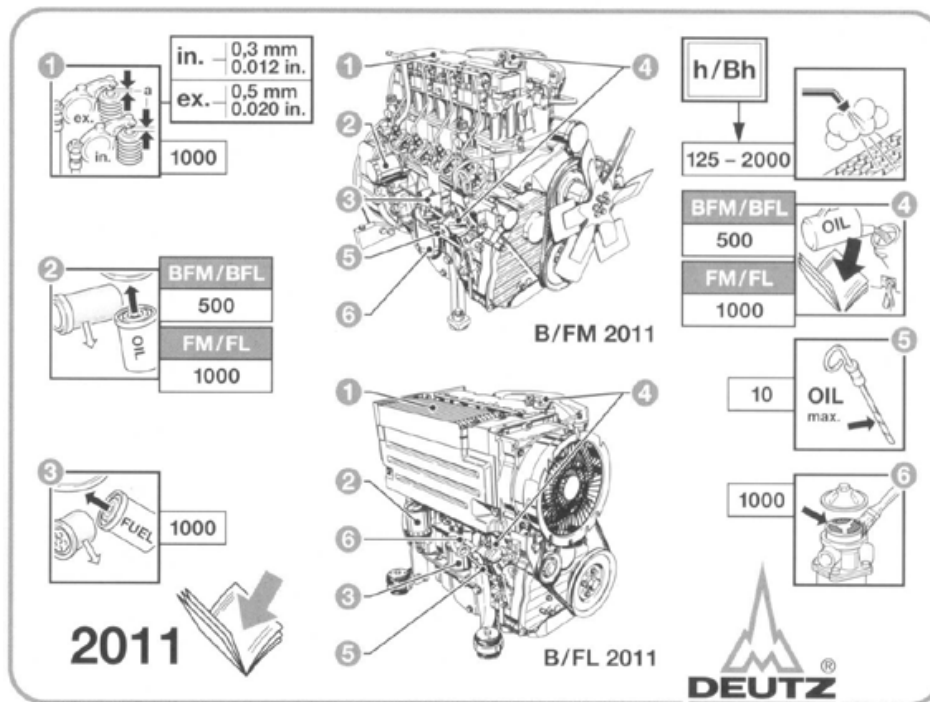

Oil Level Check

When checking the oil level, the engine must be switched off, and should stand horizontal.

- Remove the oil dipstick
- Wipe the dipstick with a non-fibrous, clean cloth.
- Insert it to the stop and remove it again.
- Check oil level at the dipstick, and top up if necessary as far as the max. mark.

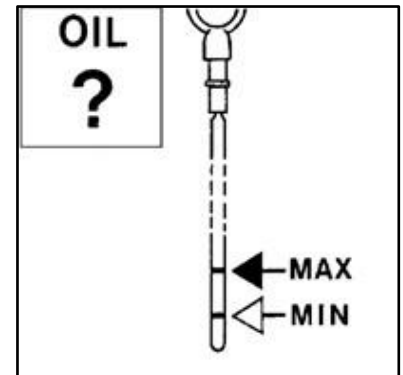

Changing Oil

Allow the engine to warm up and then switch it off. Oil temperature is about 80° C.

! CAUTION: Risk of scalding from hot oil

Please dispose of used engine oil in a manner that is compatible with the environment. We suggest you to take used oil in a sealed container to your local recycling centre or service station for reclamation. Do not throw it in the trash, pour it on the ground or down in a drain.

- Place an oil tray under the engine.
- Unscrew the oil drain plug.
- Drain the oil.
- Fit the oil drain plug with a new seal ring and tighten it firmly.
- Pour in new oil up to the MAX mark on the dipstick.
- Check the oil level after having run the engine for a short period. Top up if necessary.

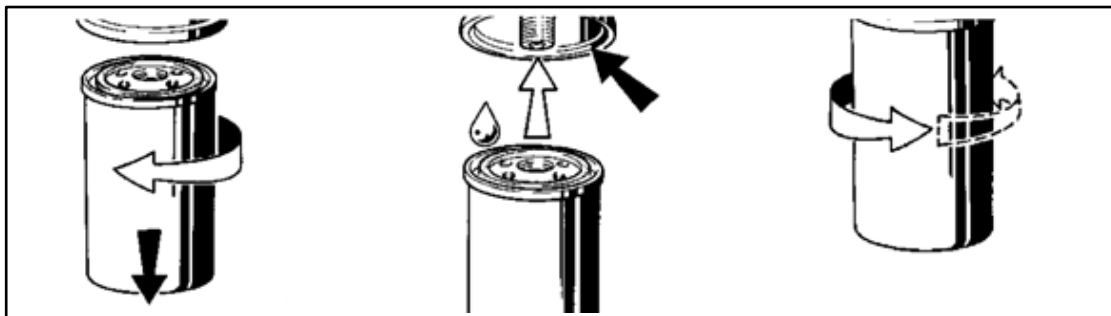
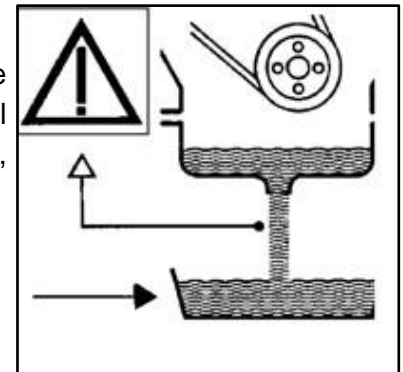

Changing the Oil Filter

- Undo the oil filter cartridge using commercial tool and spin off.
- Catch any escaping oil.
- Clean any dirt from the filter carrier sealing surface.
- Lightly oil the rubber gasket of the new oil filter cartridge.

- Manually screw in the new cartridge until gasket is flush.
- Tighten oil filter cartridge with another half-turn.
- Then check the oil level and the oil pressure.
- Check the filter cartridge seal for leaks.

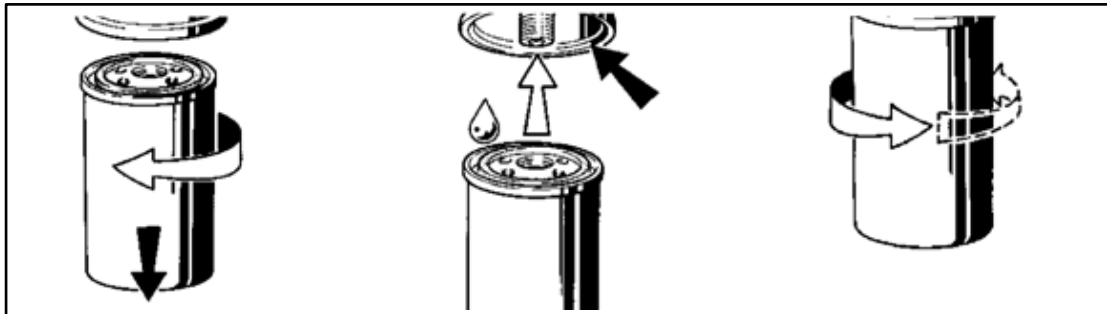

Changing the Fuel Filter

- **CAUTION:** Keep naked flames away when working on the fuel system. Do not smoke.
- Close the fuel shut-off valve.
- Undo the fuel filter cartridge using commercial tool and spin off.
- Catch any escaping fuel.
- Clean any dirt from the filter carrier sealing surface.
- Apply a light film of oil or diesel fuel to rubber gasket of new fuel filter cartridge.
- Manually screw in the new cartridge with a final half-turn.
- Open the fuel shut-off valve.
- Check the filter cartridge seal for leaks.

Changing Strainer of Fuel Filter

- **CAUTION:** Keep naked flames away when working on the fuel system. Do not smoke.
- Close the fuel shut-off valve.
- Loosen and unscrew the hexagonal nut 1.
- Remove fuel strainer cover 2 (cover and strainer, one unit)
- Clean fuel strainer 2 with diesel fuel. Replace if necessary.
- Place seal 3 in position.
- Assemble fuel strainer cover 2.
- Tighten hexagonal screw 1.
- Check for leaks.

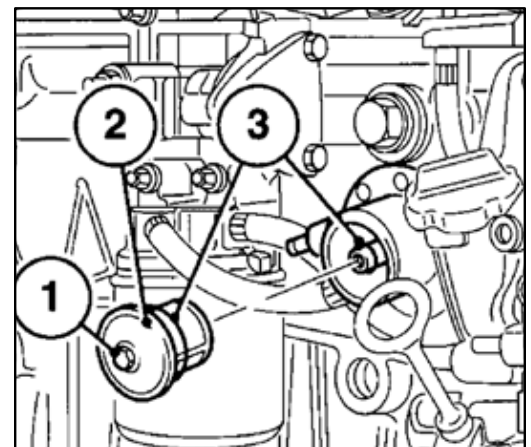

Air Cleaner

If you use the machine in dry cut, you must clean the filter cartridge every day. Otherwise you must clean it when the indicator is showing red (1). To reset the indicator, press on the button.

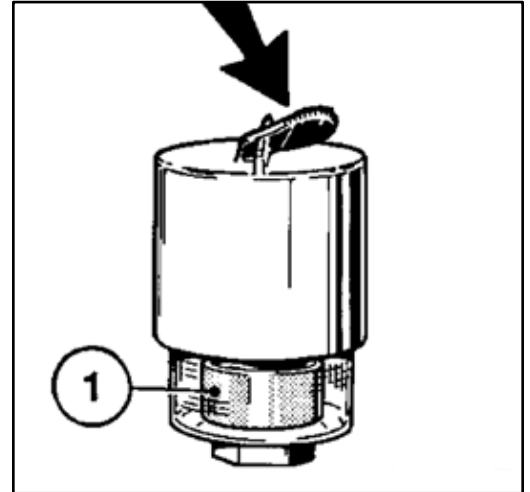

Air Cleaner Discharge Valve

Empty dust discharge valve 1 by pressing apart lips of discharge as indicated by arrows. Clean the discharge slot from time to time. Remove any caked dirt by pressing together upper section of valve.

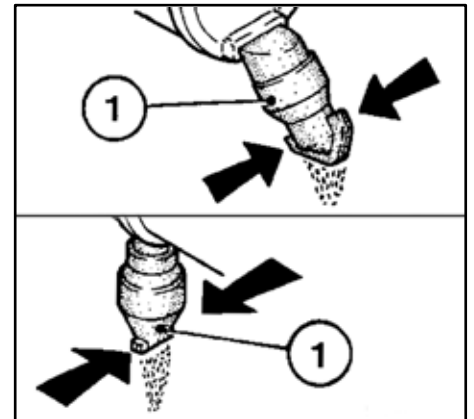

Fuel Cartridge

- Undo the clip fasteners 1.
- Take off the hood 2 and remove cartridge 3.
- Clean the cartridge, and replace it at least once a year.
- Clean cartridge 3 using compressed air (max. 5 bar). Blow out from inside to outside (or in difficult cases, tap out, taking care not to damage cartridge, or wash according to manufacturer's instructions.)
- Gaskets on filter cartridge can become damaged through regular removal and replacement. Check paper filter (light showing through) and gaskets for damage. Replace if necessary.
- After five cleaner services or after two years at latest, replace the

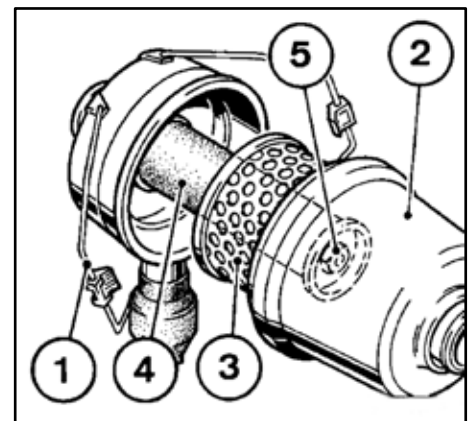

safety cartridge 4 (never clean) by undoing the hexagonal nut 5 and removing the cartridge 4.

- Install the new cartridge 3, replace hood 2 and do up the clip fasteners 1.

Alternator Belts

- Slacken off bolts 1, 2 and 3.
- Adjust alternator 4 in direction of the arrow by turning the bolt 3 until correct belt tension is achieved.
- Retighten the bolts 1, 2 and 3.

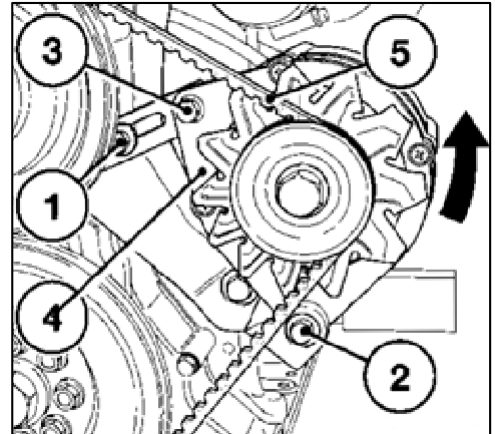

To Change the Belts

- Slacken off bolts 1, 2 and 3.
- Adjust the alternator 4 in the direction of arrow by turning the bolt 3.
- Remove and replace the belt.
- Adjust alternator 4 against direction of arrow by turning bolt 3, until correct belt tension is achieved.
- Retighten bolts 1, 2 and 3.

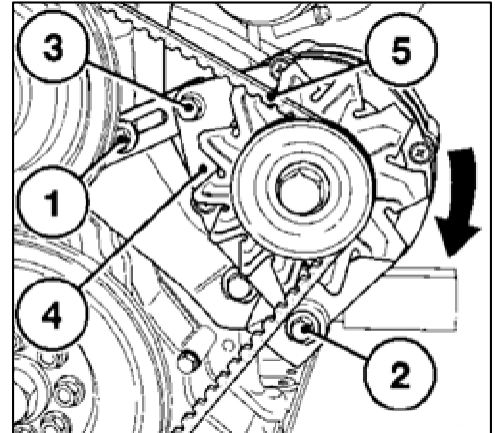

Control the Valve Clearance

Only a DEUTZ specialised dealer check the valve clearance. You also have to let a specialised dealer check your engine every 1000 hours of operation.

5.3 Troubleshooting

Fault-finding procedure

Should any fault occur during the use of the machine, turn it off. Let only qualified staff make any intervention other than the one described in the previous section.

Troubleshooting Guide

Trouble	Possible source	Resolution
Engine does not start or is difficult to start.	Fuel quality not as per operating manual	Change quality of diesel
	Incorrect oil class or quality	Change quality of oil
	Temperature too low	Use cold start oil
	Battery defective or discharged	Change or recharge battery
	Stronger fault	Contact nearest engine maintenance centre
Engine fires but stops again as soon as the crank is disengaged.	No oil pressure	Check the oil level
	Cylinder head temperature too high	Check cooling air passage
	Stronger fault	Contact nearest engine maintenance centre
Engine lacks power.	Tank run dry	Add fuel
	Air cleaner clogged	Clean or replace air filter
	Speed control lever does not remain in the selected position	Prevent speed control from moving
	Stronger fault	Contact nearest engine maintenance centre
Engine becomes excessively hot.	Air cleaner clogged	Clean or replace air filter
	Oil level too high or too low	Check oil level
	Belt to alternator broken or un-tightened	Check or change belt
Engine stops by itself during regular operation.	Tank run dry	Add fuel
	Air filter restricted	Clean or replace air filter
	No oil pressure	Check the oil level
	Stronger fault	Contact nearest engine maintenance centre

6 INFORMATIONS RELATIVES AU SERVICE APRES-VENTE GENERAL PRODUCT INFORMATION

6.1 Step Cutting

1. Follow general instructions outlined in the section Operating the Saw pages 19.
 2. When deep sawing (more than 4") or concrete with hard aggregate, sawing to full depth in several cuts should be made in incremental steps of 1-1/2 to 2 inches until the desired depth of cut is reached. In softer aggregates or asphalt, it may be possible to saw full depth in two passes.
 3. Gradually move the speed control lever forward to increase the cutting speed. If the blade stalls in the cut (which can happen when deep sawing) immediately raise blade from cut. If not done at once, the belts will spin freely and burn. Check belts for proper tension and continue sawing at a slower rate of speed.
 4. On final pass, lower the blade until it hits the sub-base (sandy color will appear in the water being discharged from the cut). Raise blade approximately 1/2" from bottom. The sand and gravel particles of the sub-base may cause premature wear or damage to the sawblade.
 5. It is common, on the final pass of the cut, for pavement to wedge blade, particularly on a hot day. When this happens, immediately stop engine. If the blade is wedged, remove the Blade Shaft Bolt and Outside Collar and move the saw away from the blade. To remove a wedged blade from the concrete, use a jack hammer and carefully chip out concrete around the blade. (Pounding or twisting the blade may cause severe damage).
 6. Go slowly with a new blade until it "opens up" that is, until you can see and feel the diamonds.
 7. Small corrections can be made by leaning on handles.
- Deep sawing is very hard on saws and blades. Experienced operators soon get a "feel" for the saw and are constantly on guard to slow down when they hit excessive steel or hard aggregate

6.2 Customer Service

When ordering spare parts, please mention:

- The serial number (seven digits).
- The code of the part.
- The exact denomination.
- The number of parts required.
- The delivery address.
- Please indicate clearly the means of transportation required such as "express" or "by air." Without specific instructions, we will forward the parts through the means which seem appropriate to us and but which is not always the quickest way.

Clear instructions will avoid problems and faulty deliveries. If not sure, please send us the defective part.

In the case of a warranty claim, the part must always be returned for evaluation.

Spare parts for the engine can be ordered with the manufacturer of the engine or with their dealer, which is often quicker and cheaper.

This machine has been manufactured by Saint-Gobain Abrasives S.A.

Saint-Gobain Abrasives S.A.

190, Bd.

J.F.

Kennedy L-

4930

BASCHAR

AGE

Grand-Duché de

Luxembourg. Tel. :

00352-50401-1

Fax : 00352-50 16 33

<http://www.construction.norton.eu>

e-mail: sales.nlx@saint-gobain.com

SAINT-GOBAIN ABRASIVES NV/SA
INDUSTRIELAAN 129
1070 ANDERLECHT: BRUSSEL
BELGIUM
TEL: +32 2 267 21 00
FAX: +32 2 267 84 24

SAINT-GOBAIN ABRASIVES, S.R.O.
VINOHRADSKÁ 184
130 52 PRAHA 3
CZECH REPUBLIC
TEL: +420 267 132 026
+420 267 132 029
FAX: +420 267 132 021-2

SAINT-GOBAIN ABRASIVES A/S
ROBERT JACOBSENS VEJ 62A
2300 KØBENHAVN S
DENMARK
TEL: +45 4675 5244

PO BOX 643706
FORTUNE TOWER OFFICE 2106
JLT BLOCK C
(NEXT TO METRO STATION)
JUMEIRA LAKE TOWER, DUBAI
UNITED ARAB EMIRATES
TEL: +971 4 431 5154
FAX: +971 4 431 5434

SAINT-GOBAIN ABRASIFS
RUE DE L'AMBASSADEUR - B.P.8
78 702 CONFLANS CEDEX
FRANCE
TEL: +33 (0)1 34 90 40 00
FAX: +33 (0)1 39 19 89 56

SAINT-GOBAIN ABRASIVES GMBH
BIRKENSTRASSE 45-49
D-50389 WESSELING
GERMANY
TEL: +49 (0) 2236 703-1
+49 (0) 2236 8996-0
+49 (0) 2236 8911-0
FAX: +49 (0) 2236 703-367
+49 (0) 2236 8996-10
+49 (0) 2236 8911-30

FÜR DEN FACHHANDEL ÖSTERREICH
TEL: +43 (00) 662 430 076

SAINT-GOBAIN ABRASIVES KFT.
1225 BUDAPEST
BÁNYALÉG U. 60/B.
HUNGARY
TEL: +36 1 371 22 50
FAX: +36 1 371 22 55

SAINT-GOBAIN ABRASIVI S.P.A
VIA PER CESANO BOSCONI 4
I-20094 CORSICO MILANO
ITALY
TEL: +39 02 44 85 1
FAX: +39 02 44 78 266

SAINT-GOBAIN ABRASIVES S.A.
190 RUE J.F. KENNEDY
L-4930 BASCHARAGE
GRAND DUCHE DE LUXEMBOURG
TEL: +352 50 401 1
FAX: +352 50 16 33
NO. VERT (FRANCE) 0800 906 903

SAINT-GOBAIN ABRASIFS, S.A.
2 ALLÉE DES FIGUIERS
AIN SEBAA - CASABLANCA
MOROCCO
TEL: +212 5 22 66 57 31
FAX: +212 5 22 35 09 65

SAINT-GOBAIN ABRASIVES BV
GROENLOSEWEG 28
7151 HW EIBERGEN
P.O. BOX 10
7150 AA EIBERGEN
THE NETHERLANDS
TEL: +31 545 466466
FAX: +31 545 474605

SAINT-GOBAIN ABRASIVES AS
POSTBOKS 11, ALNABRU,
0614 OSLO
BROBEKKVEIEN 84,
0582 OSLO
NORWAY
TEL: +47 63 87 06 00
FAX: +47 63 87 06 01

SAINT-GOBAIN HPM POLSKA SP. Z O. O.
UL. TORUŃSKA 239/241
62-600 KOŁO
POLAND
TEL: +48 63 26 17 100
FAX: +48 63 27 20 401

SAINT-GOBAIN ABRASIVOS, L. DA
ZONA INDUSTRIAL DAMAIA
I-SECTOR VIII, NO. 122
APARTADO 6050
4476 - 908 MAIA
PORTUGAL
TEL: +351 229 437 940
FAX: +351 229 437 949

SAINT-GOBAIN GLASS
BUSINESS UNIT ABRASIVI
PUNCT DE LUCRU: LOC.VETIS, JUD.
SATU MARE 447355
STR. CAREIULUI 11
PARC INDUSTRIAL RENOVATIO
ROMANIA
TEL: +40 261 839 709
FAX: +40 261 839 710

SG HPM RUS
58, F. ENGELS STR.
STROENIE 2
105082 MOSCOW
RUSSIA
TEL: +74 955 408 355
FAX: +74 959 373 224

SAINT-GOBAIN
ABRASIVES (PTY) LTD
2 MONTEER ROAD
ISANDO 1600
P.O. BOX 67
SOUTH AFRICA
TEL: +27 11 961 2000
FAX: +27 11 961 2184/5

SAINT-GOBAIN ABRASIVOS, S.A.
CTRA. DE GUIPÚZCOA, KM. 7,5
E-31195 BERRIOPLANO (NAVARRA)
SPAIN
TEL: +34 948 306 000
FAX: +34 948 306 042

SAINT GOBAIN ABRASIVES AB
GÅRDSFOGDEVÄGEN 18A
168 66 BROMMA • SVERIGE
SWEDEN
TEL: +46 8 580 881 00
FAX: +46 8 580 881 01

SAINT-GOBAIN ABRASIVES
MUEYYETZADE MAH.
GALIPDEDE CAD. NO:99, KAT:3
34425 BEYOGLU-ISTANBUL-TURKEY
TEL: 0090-212-245 85 21
FAX: 0090-212-245 85 27

SAINT-GOBAIN ABRASIVES LTD.
DOXEY RD
STAFFORD
ST16 1EA
UNITED KINGDOM
TEL: +44 1785 222 000
FAX: +44 1785 213 487



Saint-Gobain Abrasifs
190 Rue J.F. Kennedy
L-4930 Bascharage
Grand Duche de Luxembourg
Tel: +352 50 401 1
Fax: +352 50 16 33
no. vert (France) 0800 906 903

www.nortonabrasives.com/fr-fr