

# TR 201 E

SPARE PART LIST  
LISTE DE PIÈCES DE RECHANGE  
ERSATZTEILLISTE



**NORTON**  
SAINT-GOBAIN®

**clipper®**



## ENGLISH

TYPE:

S = Spare part

W = Wear part

NA = Not Available

The kits of spare parts contain all screws and bolts and the components referring itself to it.

Screws and bolts is component of standard assembly, which you can easily find at all the retailers of standard components of assembly.

All the components of standard assembly are of a quality grade 8.8.

We recommend not to use a quality grade lower than 8.8 for all the standard components of assembly.

The parts of replacements Norton CLIPPER must always be used.

Wear parts life will vary based on usage and maintenance of the machine or part. Wear parts will need to be maintained and replaced as needed. No warranty is applied to wear parts.

The components NA (Not Available) are not available in spare part.

## FRANCAIS

TYPE :

S = Pièce de rechange

W = Pièce d'usure

NA = Non disponible

Les kits de pièces détachées contiennent toute la visserie et les composants s'y rapportant.

La visserie est un composant d'assemblage standard, que vous pouvez facilement trouver chez tous les détaillants de composants d'assemblage standards.

Tous les composants d'assemblage standard sont d'une classe de qualité 8.8.

Nous recommandons de ne pas utiliser une classe de qualité inférieure à 8.8 pour tous les composants d'assemblage standards.

Pour les pièces non standard, les pièces de remplacement doivent impérativement provenir de Norton CLIPPER.

La durée de vie des pièces d'usure varie en fonction de l'utilisation et de la maintenance de la machine ou de la pièce. Les pièces d'usure devront être entretenues et remplacées au besoin. Aucune garantie n'est appliquée aux pièces d'usure.

Les composants NA (Not Available) ne sont pas disponibles en pièce de rechange.

## DEUTSCH

TYP :

S = Ersatzteile

W = Verschleißteile

NA = nicht verfügbare

Die definierten Ersatzteil-Set's beinhalten alle Ersatzteile wie Komponenten, Schrauben, Muttern etc.

Norm- bzw. Standardteile wie Schrauben, Muttern etc. können bei offiziellen Schrauben- sowie Komponentenhandler bezogen werden.

Alle Norm- bzw. Standardteile wie Schrauben, Muttern etc. entsprechen der Qualitäts- bzw. Festigungsklasse 8.8.

Wir empfehlen, keine Norm- bzw. Standardteile wie Schrauben, Muttern etc. unter der Qualitäts- bzw.

Festigungsklasse 8.8 einzusetzen.

Es dürfen nur geprüfte Norton CLIPPER-Ersatzteile eingesetzt werden.

Die Lebensdauer der Verschleißteile hängt von der Verwendung und Wartung der Maschine oder des Teils ab. Verschleißteile müssen gewartet und bei Bedarf ersetzt werden. Für Verschleißteile wird keine Garantie übernommen.

Ersatzteile sowie Komponenten mit dem Vermerk NA (NA=nicht verfügbar) sind nicht verfügbar.

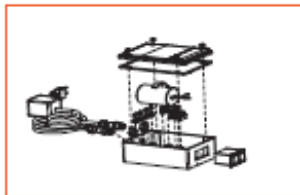

Page 16

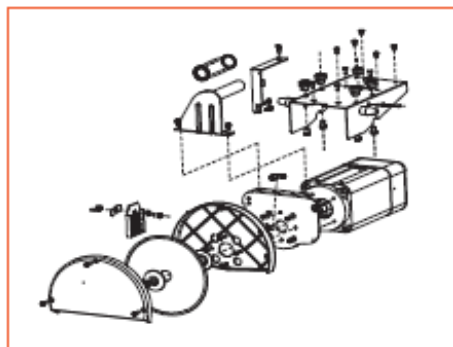

Pages 12 et 15

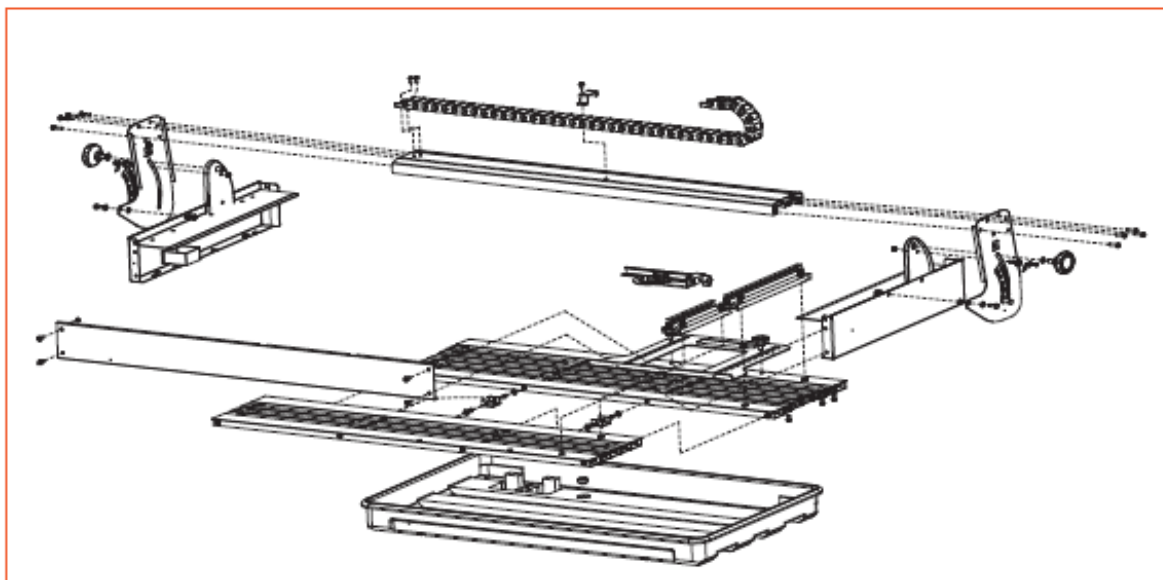

Pages 4 et 7

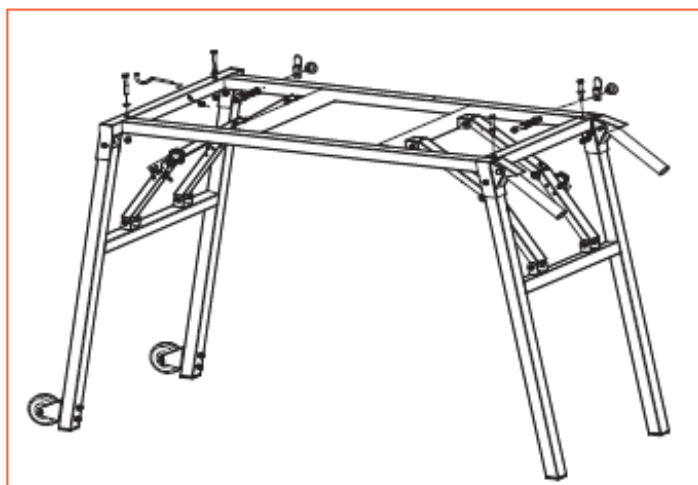

Pages 8 et 11

# Table / Table / Tafel

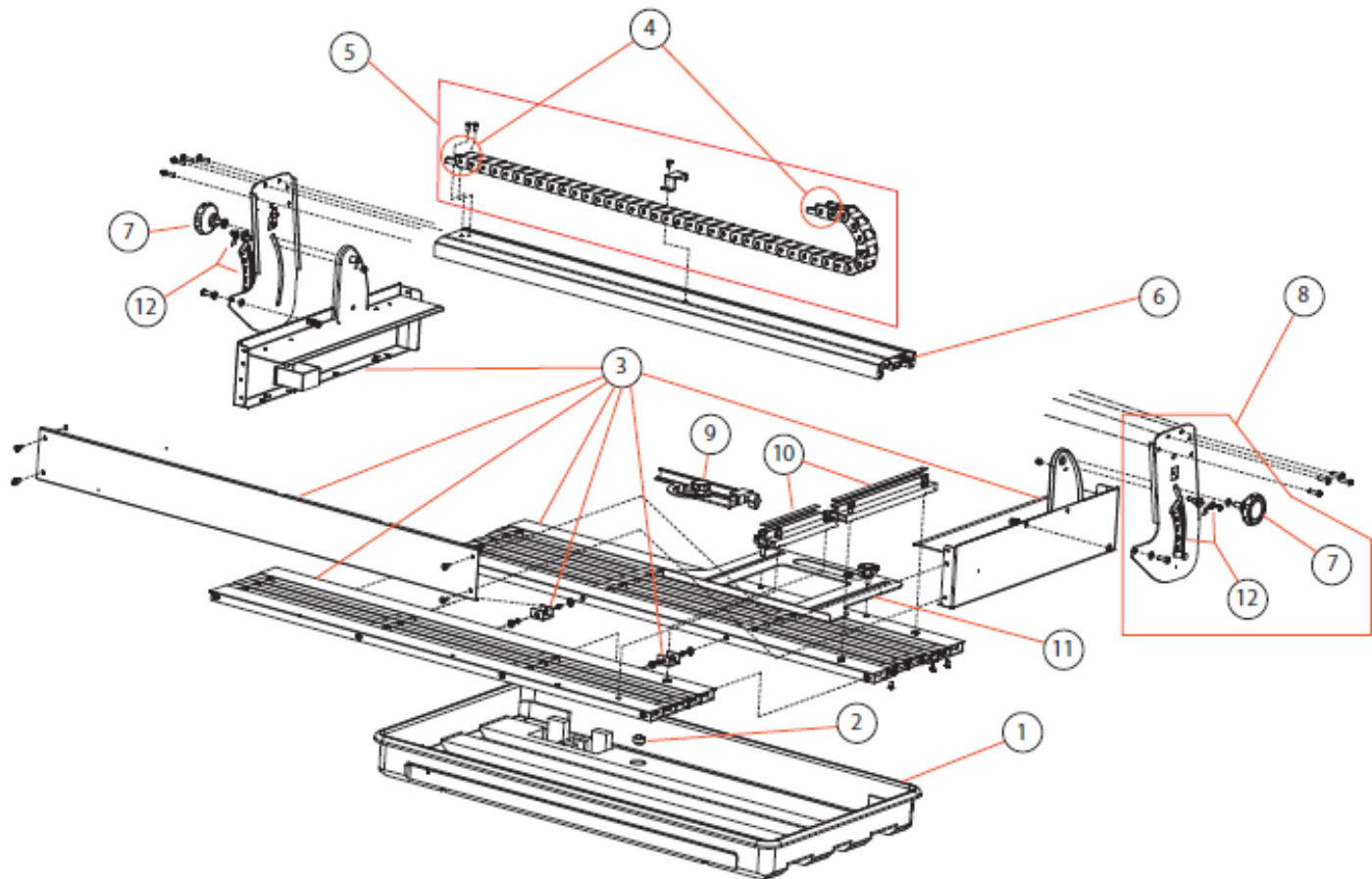

POS.	DESCRIPTION	DESCRIPTION	BESCHREIBUNG	QTY	REF	TYPE
1	Water tray	Bac à eau	Wasserwanne	1	310008300	S
2	Water plug assy.	Bouchon complet	Wasserstopfen, kompl.	1	310335333	S
3	Table assy.	Table complète	Tisch, kompl.	1	310391482	S
	Screw DIN 912 - M5X8	Vis DIN 912 - M5X8	Schraube DIN 912 – M5X8	8		
	Nut DIN 985 –M5	Ecrou DIN 985 –M5	Nuss DIN 985 – M5	10		
	Screw DIN 965 – M4X10	Vis DIN 965 –M4X10	Schraube DIN 965 – M4X10	12		
	Washer DIN 125 –Ø4,3	Rondelle DIN 125 –Ø4,3	Scheibe DIN 125 – Ø4,3	12		
	Screw DIN 7985-H –M4X12	Vis DIN 7985-H –M4X12	Schraube DIN 7985 – H-M4X12	4		
	Nut DIN 934 –M4	Ecrou DIN 934 –M4	Nuss DIN 934 – M4	4		
	Screw DIN 7985-H –M3X12	Vis DIN 7985-H –M3X12	Schraube DIN 7985-H-M3X12	4		
	M4X8 screw	Vis M4x8	Schraube M4x8	18		
	Left and right Table	Table gauche et droite	Linke und rechte Tabelle	1		
	table connector	Connection de table	Tischverbinder	2		
	Left side table support	Support de table gauche	Left Beistelltisch Unterstützung	1		
	Right side table support	Support de table droit	Recht Beistelltisch Unterstützung	1		
	Front table plate	Plat de table avant	Vordertischplatte	1		
4	Cable support end parts (SET OF 2)	Embout chemin de câble complet (jeu de 2)	Endstücke Kabelbahn, kompl. (Satz von 2)	1	510111414	S
	Screw DIN 965 – M5X12	Vis DIN 965 –M5X12	Schraube DIN 965 _ M5X12	4		
	Cable Support end	Embout chemin de câble	Endstücke Kabelbahn	2		
5	Cable support assy.	Chemin de câble complet	Kabelbahn, kompl.	1	310391372	S
	Screw	Vis	Schraube	1		
	Screw DIN 965 – M5X12	Vis DIN 965 –M5X12	Schraube DIN 965 _ M5X12	4		
	Cable Support end	Embout chemin de câble	Endstücke Kabelbahn	2		
	Cable support fixing	Fixation de chemin de cable	Kabeltrag-Befestigungs	1		
	Cable support	Chemin de câble	Kabelbahn	1		
6	Guiding rail assy.	Rail de guidage complet	Führungsschiene, kompl.	1	310391373	W
	Screw DIN 933 – M5X20	Vis DIN 933 –M5X20	Schraube DIN 933 – M5X20	8		
	Guiding rail	Rail de guidage	Führungsschiene	1		

# Table / Table / Tafel

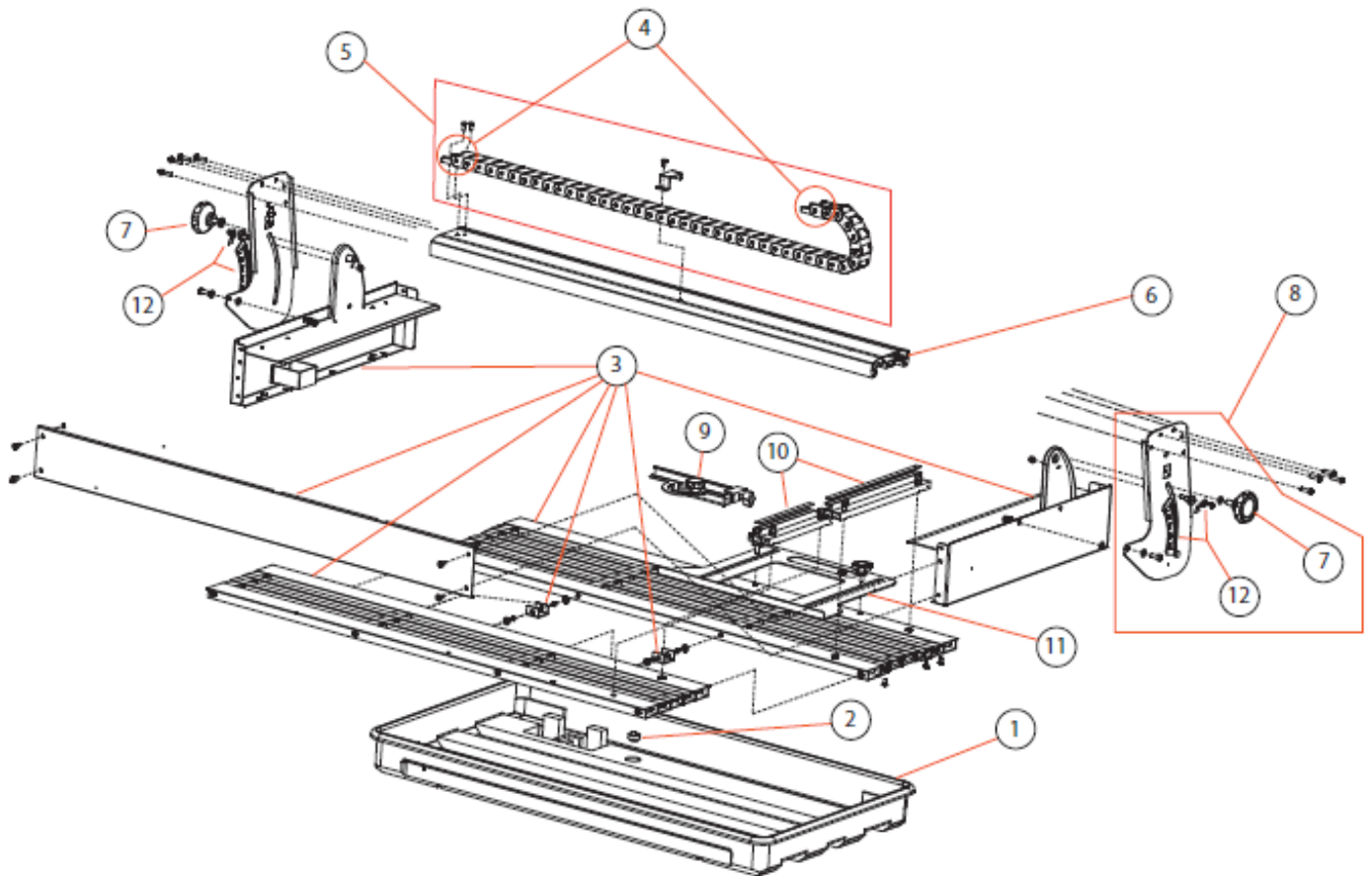

POS.	DESCRIPTION	DESCRIPTION	BESCHREIBUNG	QTY	REF	TYPE
7	<b>Securing knob M8X 20 (SET OF 2)</b>	<b>Bouton étoile à tige fileté M8X20 (jeu de 2)</b>	<b>Gewinde Feststellschrauben M8X20 (Satz von 2 Stk)</b>	1	310361061	S
	Securing knob M8X 20	Bouton étoile à tige fileté M8X20	Feststellschrauben M8X20	2		
	Washer	Rondelle	Unterlegscheibe	2		
8	<b>Rail assy support (LEFT AND RIGHT)</b>	<b>Support rail de guidage complet (gauche+ droit)</b>	<b>Stützen Führungsschiene, kompl. (Links &amp; Rechts)</b>	1	510100632	S
	Screw DIN 933 – M6X16	Vis DIN 933 – M6X16	Schraube DIN 933 – M6X16	2		
	Nut DIN 985 –M6	Ecrou DIN 985 –M6	Nuss DIN 985 – M6	2		
	Screw DIN 933 – M6X20	Vis DIN 933 – M6X20	Schraube DIN 933 – M6X20	2		
	Nut DIN 934 –M6	Ecrou DIN 934 –M6	Nuss DIN 934 – M6	2		
	Securing knob M8X 20	Bouton étoile à tige fileté M8X20	Feststellschrauben M8X20	2		
	Washer	Rondelle	Unterlegscheibe	8		
	Screw M4x6	Vis M4x6	Schraube M4x6	2		
	Arrow indicator	Flèche indicateur	Pfeilanzeiger	2		
	Indicator axes	Axe d'indicateur	Anzeigestift	2		
	graduated Sticker	Autocollant gradué	Skala Aufkleber	2		
	Rail support left and right	Support de rail gauche et droite	Links & Rechts Schienenträger	1		
9	<b>Angular Cutting guide assy..</b>	<b>Guide de coupe angulaire complet</b>	<b>Winkelschnittführung, kompl.</b>	1	310391473	S
10	<b>Material stop assy.</b>	<b>Butée de matériaux complète</b>	<b>Baustoff-Anschlag, kompl.</b>	1	310391470	S
	Screw DIN 7985-H – M6X16	Vis DIN 7985-H – M6X16	Schraube DIN 7985 – H – M6X16	4		
	Washer DIN 125 – Ø6,4	Rondelle DIN 125 – Ø6,4	Scheibe DIN 125 – Ø6,4	4		
	Material stop left	Butée droite	Anschlag links	1		
	Material stop right	Butée gauche	Anschlag rechts	1		
11	<b>Lateral guide of cut assy.</b>	<b>Guide de coupe latéral complet</b>	<b>Längsschnittführung, kompl.</b>	1	310391437	S
	Knob	Bouton étoile	Feststellmutter	2		
	Lateral guide of cut	Guide de coupe latéral	Längsschnittführung	1		
12	<b>Indicator complete</b>	<b>Indicateur complets</b>	<b>Anzeiger, kompl.</b>	1	310476844	S
	Arrow indicator	Flèche indicateur	Pfeilanzeiger	2		
	Indicator axes	Axe d'indicateur	Anzeigestift	2		
	graduated Sticker	Autocollant gradué	Staffel Sticker	2		

# Main frame / Chassis principal / Rahmen

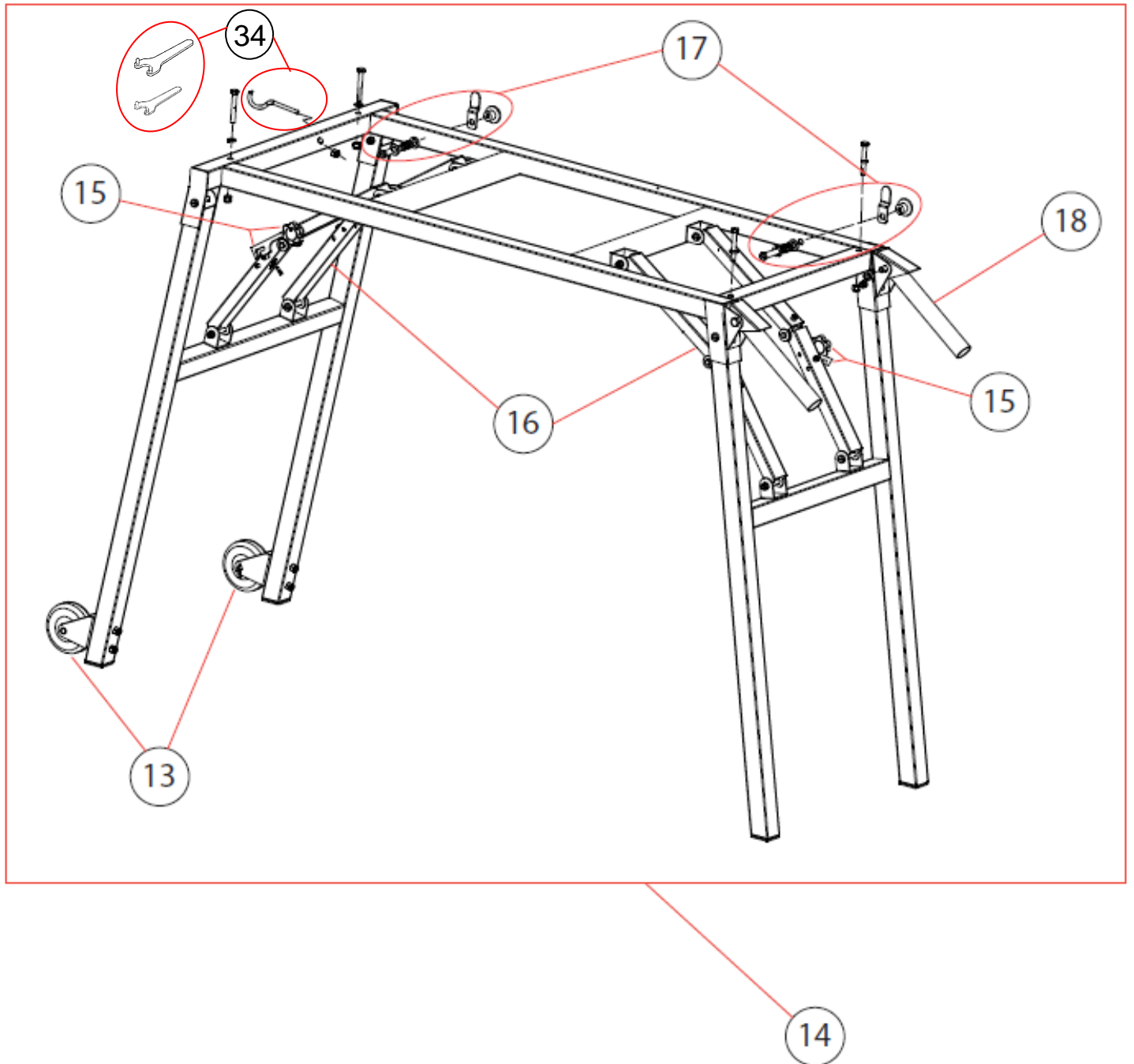

POS.	DESCRIPTION	DESCRIPTION	BESCHREIBUNG	QTY	REF	TYPE
13	<b>Transport wheel (SET OF 2)</b>	<b>Roue de transport complète (jeu de 2)</b>	<b>Transportträger, kompl. (Satz von 2 Stk)</b>	1	510100758	S
	Screw DIN 603 – M6X40	Vis DIN 603 – M6X40	Schraube DIN 603 – M6X40	8		
	Washer DIN 9021 – Ø6,4	Rondelle DIN 9021 Ø6,4	Scheibe DIN 9021 – Ø6,4	4		
	Nut DIN 315 – M6	Ecrou DIN 315 – M6	Nuss DIN 315 – M6	1		
	Wheel	Roue	Rad	2		
	Wheel Support	support de roue	Radträger	2		
	wheel axes	Axe de roue	Radachse	2		
14	<b>Complete frame assy..</b>	<b>Châssis inférieur complet</b>	<b>Untergestell, kompl.</b>	1	310391509	S
	Screw DIN 84 – M6X45	Vis DIN 84 – M6X45	Schraube DIN 84 – M6X45	12		
	Washer DIN 125 – Ø6,4	Rondelle DIN 125 – Ø6,4	Scheibe DIN 125 – Ø6,4	16		
	Nut DIN 985 – M6	Ecrou DIN 985 – M6	Nuss DIN 985 – M6	4		
	Screw DIN 933 – M6X45	Vis DIN 933 – M6X45	Schraube DIN 933 – M6X45	8		
	Nut DIN 985 – M5	Ecrou DIN 985 – M5	Nuss DIN 985 – M5	1		
	Right arm	bras droit	Rechts Arm	2		
	Left arm	bras gauche	Links Arm	2		
	Securing knob M5 (SET OF 2)	Bouton étoile M5 (jeu de 2)	Feststellmutter M5 (Satz von 2)	2		
	blocking plate	plaque de bloquage	Blockierplatte	2		
	Nylon nut	Ecrou frein	Nylon Mutter	8		
	Screw	Vis	Scraube	8		
	Frame	Châssis inférieur	Untergestell	1		
	Water tray securing device	Fixation bac à eau	Wasserwannenbefestigungen	2		

# Main frame / Chassis principal / Rahmen

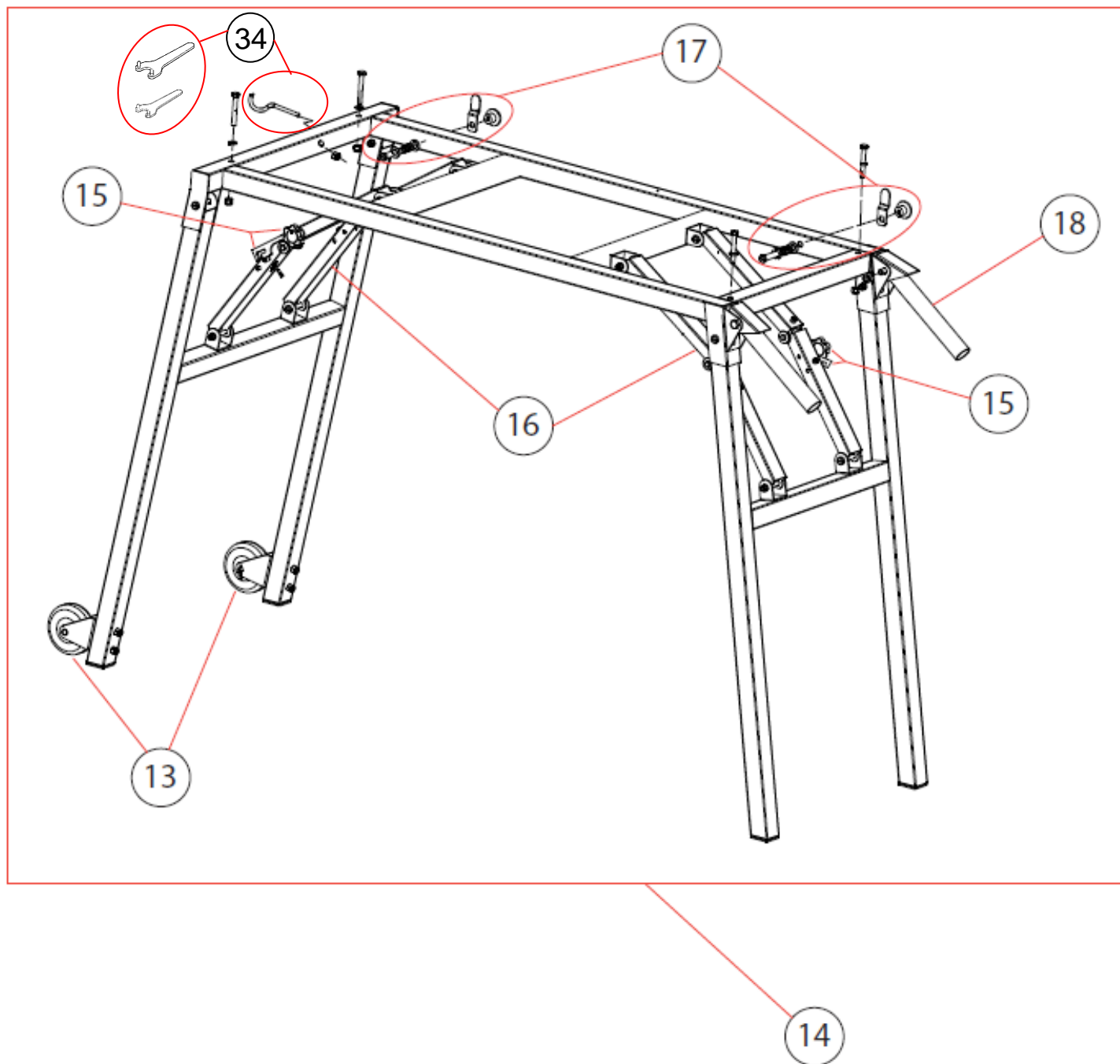

POS.	DESCRIPTION	DESCRIPTION	BESCHREIBUNG	QTY	REF	TYPE
15	Securing knob	Bouton étoile de sécurité	Sicherheits-Feststellschrauben	1	310476896	S
	Securing knob M5	Bouton étoile M5	Feststellmutter M5	2		
	blocking plate	plaque de bloquage	Blockierplatte	2		
16	blocking arm kit	Kit Bras de Blocage	Sperrarm Satz	1	510100763	S
	Right arm	bras droit	Rechts Arm	1		
	Left arm	bras gauche	Links Arm	1		
	Securing knob M5 (SET OF 2)	Bouton étoile M5 (jeu de 2)	Feststellmutter M5 (Satz von 2stk)	1		
	blocking plate	plaque de bloquage	Blockierplatte	1		
	Nylon nut	Ecrou frein	Nylon Mutter	4		
	Screw	Vis	Schraube	4		
17	Water tray securing device (SET OF 2)	Fixation bac à eau (jeu de 2)	Wasserwannenbefestigung (Satz von 2Stk)	1	510100761	S
18	Handle assy. (SET OF 2)	Poignée complète (jeu de 2)	Transportgriffe, kompl. (Satz von 2Stk)	1	510100759	S
	Screw DIN 933 – M8X40	Vis DIN 933 – M8X40	Schraube DIN 933 – M8X40	2		
	Nut DIN 985 – M8	Ecrou DIN 985 – M8	Nuss DIN 985 – M8	1		
	Handle	Poignée	Transportgriffe	2		
	Handle support	Support poignée	Transportgriffe Unterstützung	2		
34	Toolkit	Kit outils	Werkzeug	1	310545208	S
	Wrench 13 mm	Clé 13 mm	schraubenzieher 13 mm	1		
	Wrench 8 mm	Clé 8 mm	schraubenzieher 8 mm	1		
	screw driver	Tournevis cruciforme	schraubenschlüssel	1		
	Hook for tools	Crochet pour outil	Haken für Werkzeug	1		
	nut ISO4032 - M5	ecrou ISO4032 - M5	mutter ISO4032 - M5	2		

# Motor / Moteur / Motor

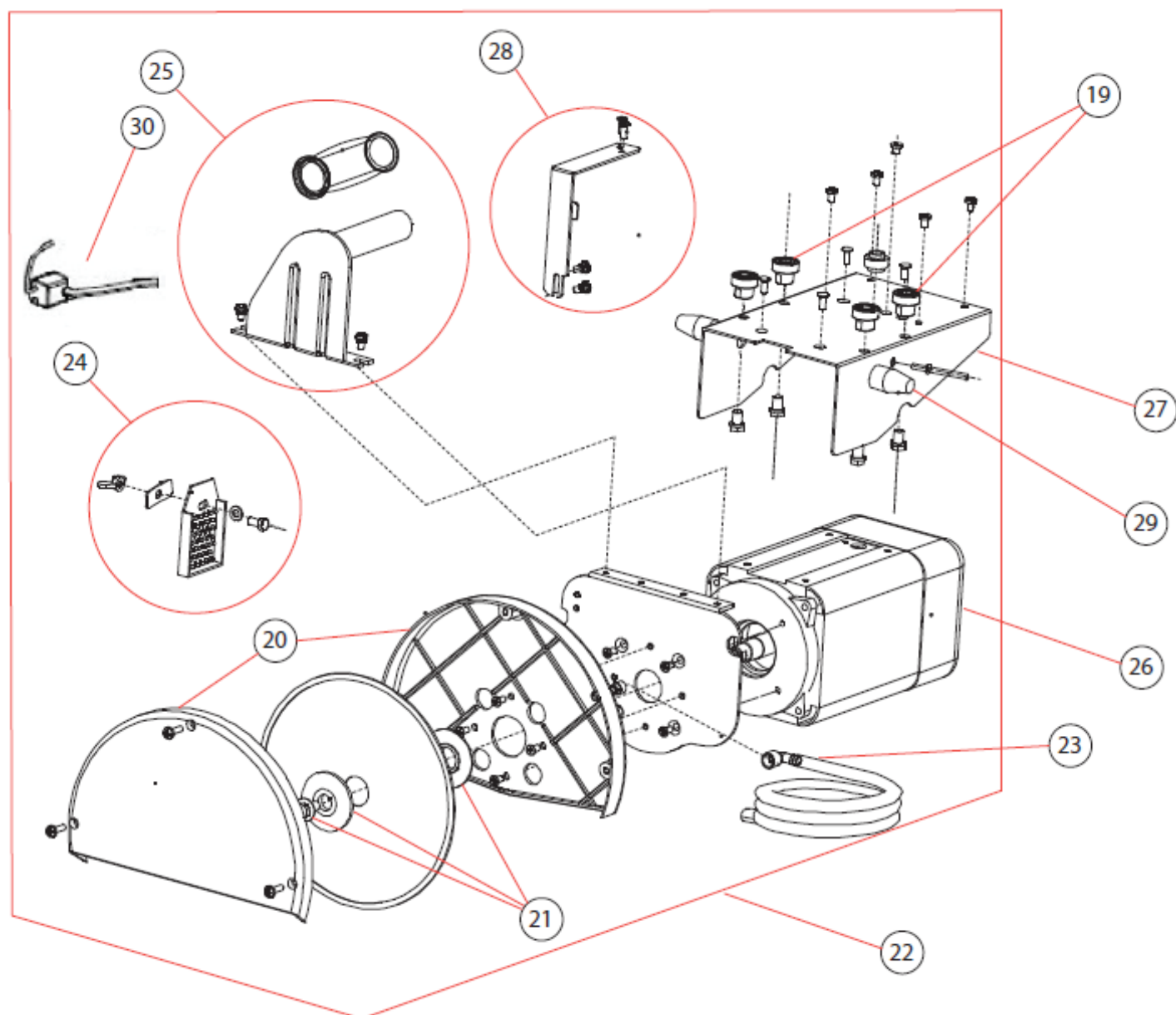

POS.	DESCRIPTION	DESCRIPTION	BESCHREIBUNG	QTY	REF	TYPE
19	<b>Guiding wheels assy (SET OF 4)</b>	<b>Ensemble de roulette de guidage (jeu de 4)</b>	<b>Rollenführungen, kompl. (Satz von 4Stk)</b>	1	310391507	W
	Eccentric wheels	Roulette excentrique	Exzenterrolle	2		
	Fixe wheels	Roulettes fixe	Feste Rolle	2		
	Screw	Vis	Schraube	4		
20	<b>Blade guard assy.</b>	<b>Carter complet</b>	<b>Schutzgehäuse, kompl.</b>	1	510100629	S
	Screw DIN 7985-H -M5X25	Vis DIN 7985-H -M5X25	Schraube DIN 7985-H-M5X25	3		
	Screw DIN 7985-H -M8X8	Vis DIN 7985-H -M8X8	Schraube DIN 7985-H-M8X8	4		
	Fixe blade guard	Carter de disque fixe	Festschutzgehäuse	1		
	Mobile blade guard	Carter de disque mobile	Mobilschutzgehäuse	1		
21	<b>Flanges kit</b>	<b>Kit Flasque</b>	<b>Flansche Satz</b>	1	510100630	S
	Screw DIN 6921 - M8X16 - LHTH	Vis DIN 6921 - M8X16 - pas gauche	Linksgewinde Schraube DIN 6921 - M8X16	1		
	Mobile flange	Flasque mobile	Lösebare Flansche	1		
	Fixed flange	Flasque fixe	Feste Flansche	1		
22	<b>Cutting head assy. 230V</b>	<b>Tête de coupe complète 230V</b>	<b>230V Schneidkopf, kompl.</b>	1	310391506	S
	<b>Cutting head assy. 115V</b>	<b>Tête de coupe complète 115V</b>	<b>115V Schneidkopf, kompl.</b>	1	310479882	S
	threaded rod DIN976 -M6X50	Tige filetée DIN976 - M6X50	Gewindestange DIN976 - M6X50	1		
	Washer DIN 9021 - Ø6,4	Rondelle DIN 9021 - Ø6,4	Scheibe DIN 9021 - Ø6,4	1		
	Nut DIN 934 -M6	Ecrou DIN 934 -M6	Nuss DIN 934 - M6	1		
	Nut DIN 315 -M6	Ecrou DIN 315 -M6	Nuss DIN 315 - M6	1		
	Screw DIN 7985-H -M5X25	Vis DIN 7985-H -M5X25	Schraube DIN 7985-H-M5X25	3		
	Screw DIN 7985-H -M8X8	Vis DIN 7985-H -M8X8	Schraube DIN 7985-H-M8X8	8		
	Fixe blade guard	Carter de disque fixe	Festes Scheibehäuseschutz	1		
	Mobile blade guard	Carter de disque mobile	Loserbares Scheibehäuseschutz	1		
	Motor support	Support moteur	Motoranbauplatte	1		
	Screw DIN 965 - M6X12	Vis DIN 965 - M6X12	Schraube DIN 965 - M6X12	4		
	Blade guard support	Support de carter	Gehäuseschutz Unterstützung	1		
	Eccentric wheels	Roulette excentrique	Exzenterrolle	2		
	Fixe wheels	Roulettes fixe	Festrolle	2		
	Screw	Vis	Schraube	4		
	Electric motor 230V	Moteur électrique 230V	E-Motor 230V	1		
	Electric motor 115V	Moteur électrique 115V	E-Motor 115V	1		
	Screw DIN6921 - M8X16 -LHTH	Vis DIN6921 -M8X16 -pas gauche	Schraube DIN6921 -M8X16 - Linksgewinde	1		
	Mobile flange	Flasque mobile	Lösebare Flansche	1		
	Fixed flange	Flasque fixe	Feste Flansche	1		
	Rubber stop. (SET OF 2)	Butée caoutchouc (jeu de 2)	Gummianschlag (Satz von 2Stk)	2		
	Watering kit	Kit Arrosage	Bewässerung Satz	1		
	Splash guard assy.	Bavette complète	Spritzschutzlappen, kompl.	1		
	Handle assy. Cutting head	Poignée tête de coupe complète	Schneidkopf Handgriff, kompl.	1		
	Cable support assy	Support câble complet	Kabelstütze kompl.	1		
	Water pump	Pompe à eau	Wasserpumpe	1		

# Motor / Moteur / Motor

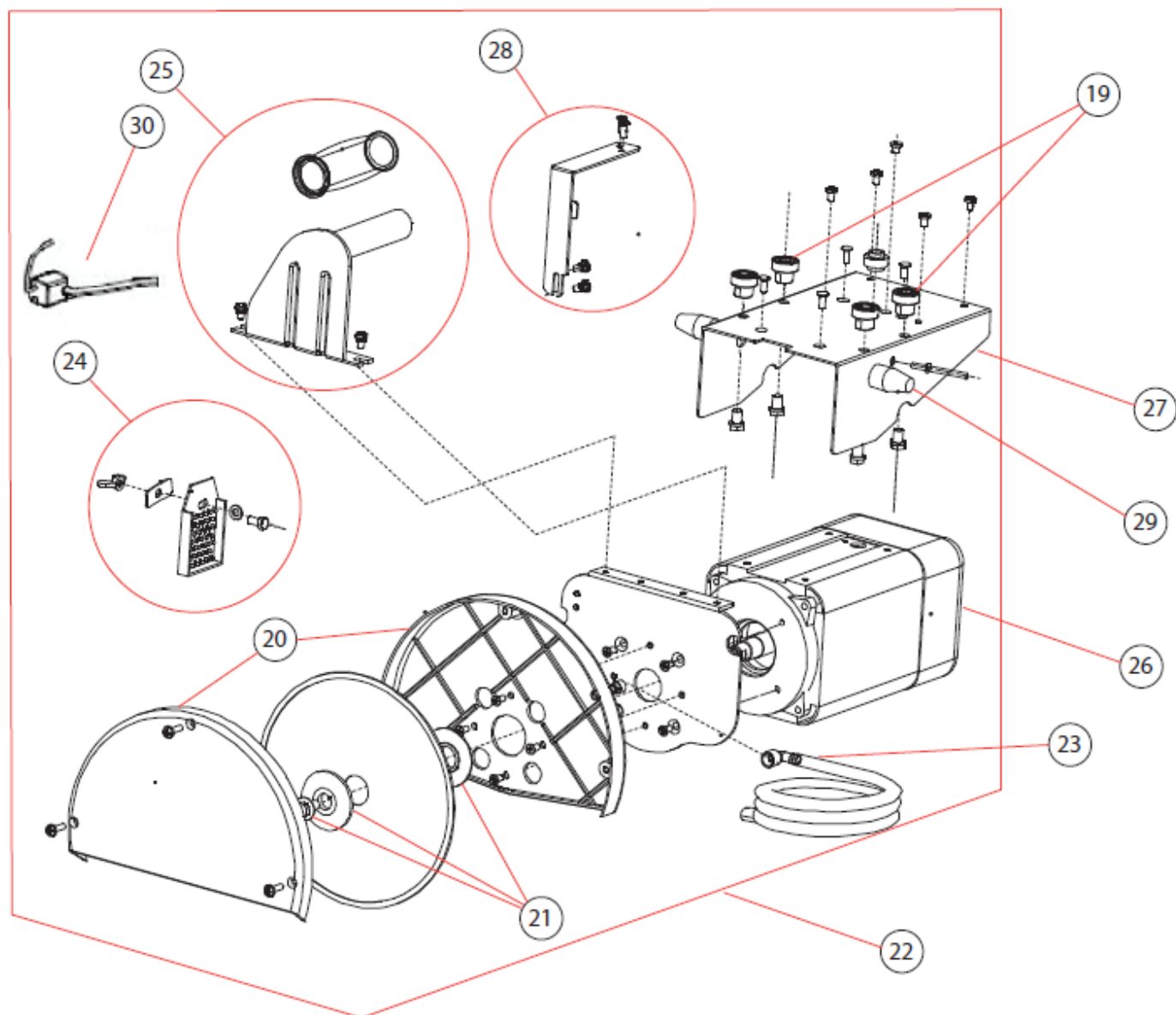

POS.	DESCRIPTION	DESCRIPTION	BESCHREIBUNG	QTY	REF	TYPE
23	<b>Watering kit</b>	<b>Kit Arrosage</b>	<b>Bewässerung Satz</b>	1	310476897	S
	Water hose	Flexible pompe à eau	Wasserschlauch	1		
	Elbow water nozzle	Coude buse d'eau	Büsenwasserverteilung Winkel	1		
24	<b>Splash guard assy.</b>	<b>Bavette complète</b>	<b>Spritzschutzlappen, kompl.</b>	1	310391483	W
	Screw DIN 933 – M6X16	Vis DIN 933 –M6X16	Schraube DIN 933 – M6X16	1		
	Nut DIN 315-M6	Ecrou DIN 35-M6	Nuss DIN 315 – M6	1		
	Plate	Plaque	Platte	1		
	Washer	Rondelle	Unterlegscheibe	1		
	Splash guard	Bavette	Spritzschutzlappen	1		
25	<b>Handle assy. Cutting head</b>	<b>Poignée tête de coupe complète</b>	<b>Handgriff, kompl.</b>	1	310391436	S
	Screw DIN 7985-H –M5X25	Vis DIN 7985-H –M5X25	Schraube DIN 7985 – H- M5X25	2		
	Washer DIN 125 – Ø5,3	Rondelle DIN 125 –Ø5,3	Scheibe DIN 125 – Ø5,3	2		
	Handle Cutting head	Poignée tête de coupe	Handgriff	1		
	Rubber handle	Poignée caoutchouc	Gummigriff	1		
26	<b>Electric motor 230V</b>	<b>Moteur électrique 230V</b>	<b>E-Motor 230V</b>	1	310391439	S
	<b>Electric motor 115V</b>	<b>Moteur électrique 115V</b>	<b>E-Motor 115V</b>	1	510100757	S
27	<b>Motor support</b>	<b>Support moteur</b>	<b>Motoranbauplatte</b>	1	310391471	S
	Screw DIN 965 – M6X12	Vis DIN 965 – M6X12	Schraube DIN 965 – M6X12	4		
	Motor support	Support moteur	Motoranbauplatte	1		
28	<b>Cable support assy</b>	<b>Support câble complet</b>	<b>Kabelstütze, kompl.</b>	1	310391508	S
	Screw DIN 7985-H –M5X10	Vis DIN 7985-H –M5X10	Schraube DIN 7985 – H – M5X10	3		
	Washer DIN 125 – Ø5,3	Rondelle DIN 125 – Ø5,3	Scheibe DIN 125 – Ø5,3	3		
	Cable support	Support de câble	Kabelstütze	1		
29	<b>Rubber stop. (SET OF 2)</b>	<b>Butée caoutchouc (jeu de 2)</b>	<b>Gummipuffer (Satz von 2Stk)</b>	1	510136495	S

# Electric box / Boitier électrique / elektrischer Kasten

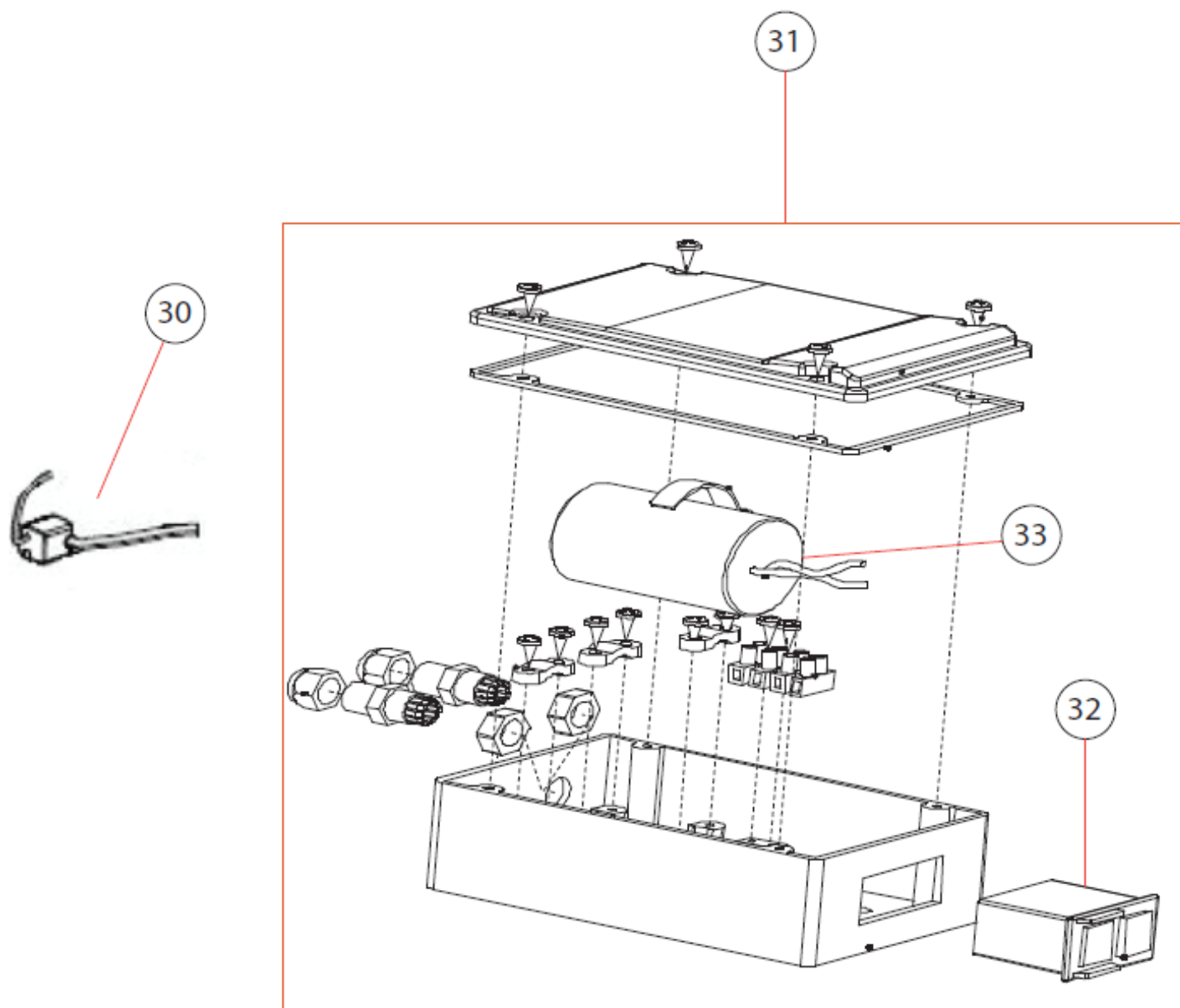

POS.	DESCRIPTION	DESCRIPTION	BESCHREIBUNG	QTY	REF	TYPE
30	Water pump 230V	Pompe à eau 230V	Wasserpumpe 230 V	1	310365204	W
	Water pump 115V	Pompe à eau 115V	Wasserpumpe 115V	1	310373445	W
31	Connecting box assy.230V	Boitier de raccordement complet 230V	E-Anschlußkasten, kompl. 230V	1	510100754	S
	Connecting box assy.115V	Boitier de raccordement complet 115V	E-Anschlußkasten, kompl.115V	1	510100755	S
	Screw DIN 7981 – M4X10	Vis DIN 7981 – M4X10	SchraubeDIN 7981 – M4X10	4		
	Screw DIN 7985-H – M5X8	Vis DIN 7985-H – M5X8	Schraube DIN7985 – H – M5X8	4		
	Nut DIN 985 –M5	Ecrou DIN 985 –M5	Nuss DIN 985 – M5	1		
	plastic screw	Vis plasctique	Kunststoffschraube	12		
	switch cover	Couvercle de switch	Schalterabdeckung	1		
	Capacitor nip	Fixation de condensateur	Kondensatorbefestigung	1		
	Capacitor	Condensateur	Kondensator	1		
	connection block	connection électrique	Anschlussblock	1		
	switch	Interrupteur	Schalter	1		
	Box bottom	Boitier inférieur	Unteranschlußkasten	1		
	Cable clamp Press	Presse étoupe	Kabelklemme Press	2		
	pressing board	Plaque de pression	Pressplatte	3		
	Protecting cable set	Jeux de protection de cable	Schutz von Kabelsatz	1		
	Pressurize circle	Vis pressurisation	Druckausgleich Schraube	1		
	water proof seal	Joint d'étanchéité	Dichtungsring	1		
32	Switch 230V	Interrupteur 230V	Schalter 230V	1	310479885	S
	Switch 115V	Interrupteur 115V	Schalter 115V	1	510100756	S
33	Capacitor 230V	Condensateur 230V	Kondensator 230V	1	310391375	S
	Capacitor 115V	Condensateur 115V	Kondensator 115V	1	510100633	S





SAINT-GOBAIN ABRASIVES  
INDUSTRIEWEG 21  
9420 ERPE-MERE  
BELGIUM  
TEL: +32(0) 2 267 21 00

SAINT-GOBAIN ABRASIVES, S.R.O.  
POČERNICKÁ 272/96, MALEŠICE  
108 00 PRAHA 10  
CZECH REPUBLIC  
TEL: +420 255 719 326  
FAX: +420 255 719 321

SAINT-GOBAIN ABRASIVES A/S  
DYBENDALSVÆNGET 2,  
DK-2630 TAASTRUP  
DENMARK  
TEL: +45 4675 5244

SAINT-GOBAIN ABRASIVES MIDDLE  
EAST  
JEBEL ALI FREE ZONE,  
PLOT NO. S10817  
PO BOX 261484, DUBAI •  
UNITED ARAB EMIRATES  
TEL: + 971 (4) 8011 800  
FAX: +971 (4) 8011 801

SAINT-GOBAIN ABRASIFS  
RUE DE L'AMBASSADEUR - B.P.8  
78 702 CONFLANS CEDEX  
FRANCE  
TEL: +33 (0)1 34 90 40 00  
FAX: +33 (0)1 39 19 89 56

SAINT-GOBAIN ABRASIVES GMBH  
BIRKENSTRASSE 45-49  
D-50389 WESSELING  
GERMANY  
TEL: +49 (0) 2236 703-1  
+49 (0) 2236 8996-0  
+49 (0) 2236 8911-0  
FAX: +49 (0) 2236 703-367  
+49 (0) 2236 8996-10  
+49 (0) 2236 8911-30

FÜR DEN FACHHANDEL  
ÖSTERREICH  
TEL: +43 (00) 662 430 076

SAINT-GOBAIN ABRASIVES KFT.  
1225 BUDAPEST  
BÁNYALÉG U. 60/B.  
HUNGARY  
TEL: +36 1 371 22 50  
FAX: +36 1 371 22 55

SAINT-GOBAIN ABRASIVI S.P.A  
VIA PER CESANO BOSCONI 4  
I-20094 CORSICO MILANO  
ITALY  
TEL: +39 02 44 851  
FAX: +39 02 44 78 266

SAINT-GOBAIN ABRASIVES S.A.  
190 RUE J.F. KENNEDY  
L-4930 BASCHARAGE  
GRAND DUCHE DE LUXEMBOURG  
TEL: +352 50 401 1  
FAX: +331 83 717 792  
NO. VERT (FRANCE): 0800 906 903

SAINT-GOBAIN ABRASIFS, S.A.  
2 ALLÉE DES FIGUIERS  
AIN SEBAÂ - CASABLANCA  
MOROCCO  
TEL: +212 5 22 66 57 31  
FAX: +212 5 22 35 09 65

SAINT-GOBAIN ABRASIVES BV  
GROENLOSEWEG 28  
7151 HW EIBERGEN  
P.O. BOX 10  
7150 AA EIBERGEN  
THE NETHERLANDS  
TEL: +31 545 466466  
FAX: +31 545 474605

SAINT-GOBAIN ABRASIVES AS  
POSTBOKS 11, ALNABRU, 0614 OSLO  
BROBEKKVEIEN 84,  
0582 OSLO • NORWAY  
TEL: +47 63 87 06 00  
FAX: +47 63 87 06 01

SAINT-GOBAIN HPM POLSKA SP. Z O.O.  
UL. NORTON 1,  
62-600 KOŁO • POLAND  
TEL: +48 63 26 17 100  
FAX: +48 63 27 20 401

SAINT-GOBAIN ABRASIVOS, L. DA  
ZONA INDUSTRIAL DA MAIA  
I-SECTOR VIII, NO. 122  
APARTADO 6050  
4476 - 908 MAIA  
PORTUGAL  
TEL: +351 229 437 940  
FAX: +351 229 437 949

SAINT-GOBAIN GLASS  
BUSINESS UNIT ABRASIVI  
PUNCT DE LUCRU : LOC.VETIS, JUD.  
SATU MARE 447355  
STR. CAREIULUI 11  
PARC INDUSTRIAL RENOVATIO  
ROMANIA  
TEL: +40 261 839 709  
FAX: +40 261 839 710

SG HPM RUS  
58, F. ENGELS STR.  
STROENIE 2  
105082 MOSCOW  
RUSSIA  
TEL: +74 955 408 355  
FAX: +74 959 373 224

SAINT-GOBAIN  
ABRASIVES (PTY) LTD  
2 MONTEER ROAD  
ISANDO 1600  
P.O. BOX 67  
SOUTH AFRICA  
TEL: +27 11 961 2000  
FAX: +27 11 961 2184/5

SAINT-GOBAIN ABRASIVOS, S.A.  
CTRA. DE GUIPÚZCOA, KM. 7,5  
E-31195 BERRIOPLANO (NAVARRA)  
SPAIN  
TEL: +34 948 306 000  
FAX: +34 948 306 042

SAINT GOBAIN ABRASIVES AB  
GÅRDSFOGDEVÄGEN 18A  
168 66 BROMMA • SVERIGE  
SWEDEN  
TEL: +46 8 580 881 00  
FAX: +46 8 580 881 30

SAINT-GOBAIN INOVATIF MALZEMELER  
VE ASINDIRICI SAN. TIC. AS.  
ALTAYÇEŞME MAH. ÇAMLI SOK. NO:21  
ESAS OFİSPARK KAT:9 34843  
MALTEPE, İSTANBUL • TURKEY  
TEL: 0090-216-217 12 50  
FAX: 0090-216-442 40 74

SAINT-GOBAIN ABRASIVES LTD.  
DOXEY RD  
STAFFORD  
ST16 1EA  
UNITED KINGDOM  
TEL: +44 1785 222 000  
FAX: +44 1785 213 487



Saint-Gobain Abrasifs  
190 Rue J.F. Kennedy  
L-4930 Bascharage  
Grand Duché de Luxembourg  
Tel: +331 83 717 792  
Fax: +352 50 16 33  
no. vert (France) 0800 906 903

[www.nortonabrasives.com/fr-fr](http://www.nortonabrasives.com/fr-fr)