

TT 250 G

OPERATING INSTRUCTIONS



NORTON
SAINT-GOBAIN®

clipper®



Declaration of conformity

The undersigned manufacturer:

SAINT - GOBAIN ABRASIVES S.A.
190, BD J.F. KENNEDY
L- 4930 BASCHARAGE

Declares that this product:

Tile saw (Code)

TT 250 G 230V (70184625705)

TT 250 G 230V UK (70184626965)

TT 250 G 115V (70184627049)

is in conformity with the following Directives:

- ***European Machinery Directive 2006/42/CE***
- ***"LOW VOLTAGE" 2006/95/CE***
- ***Electromagnetic Compatibility Directive 2004/108/CE***

and European standard:

- ***EN 12418 – Masonry and stone cutting-off machines for job site – Safety***

A handwritten signature in black ink, appearing to read "Olivier Plenert", written over a light grey horizontal line.

Olivier Plenert
Machine Design Manager

TT 250 G

OPERATING INSTRUCTIONS

1	Basic Safety Instructions	6
1.1	<i>Symbols</i>	6
1.2	<i>Machine plate</i>	7
1.3	<i>Safety instructions for particular operating phases</i>	7
2	Machine description	8
2.1	<i>Short description</i>	8
2.2	<i>Purpose of use</i>	8
2.3	<i>Layout</i>	8
2.4	<i>Technical Data</i>	9
3	Assembly and commissioning	10
3.1	<i>Tool assembly</i>	10
3.2	<i>Blade guard assembly</i>	11
3.3	<i>Guide-a-cut assembly</i>	11
3.4	<i>Electrical connections</i>	11
3.5	<i>Starting the machine</i>	11
3.6	<i>Water cooling system</i>	11
4	Transport and storing	12
4.1	<i>Securing for transport</i>	12
4.2	<i>Long period of inactivity</i>	12
5	Operating the machine	13
5.1	<i>Site of work</i>	13
5.2	<i>Cutting methods</i>	13
5.3	<i>Bevel cut</i>	13
5.4	<i>General advice for the cutting</i>	13
6	Maintenance and servicing	14
7	Faults: causes and cures	15
7.1	<i>Fault-finding procedures</i>	15
7.2	<i>Trouble-shooting guide</i>	15
7.3	<i>Circuit diagram</i>	16
7.4	<i>Customer service</i>	17

1 Basic Safety Instructions

The TT250G is exclusively designed for the cutting of tiles mainly on construction sites. Uses other than the manufacturer's instructions shall be considered as contravening the regulations. The manufacturer shall not be held responsible for any resulting damage. Any risk shall be borne entirely by the user. Observing the operating instructions and compliance with inspection and servicing requirements shall also be considered as included under use in accordance with the regulations.

1.1 Symbols

Important warnings and pieces of advice are indicated on the machine using symbols. The following symbols are used on the machine:

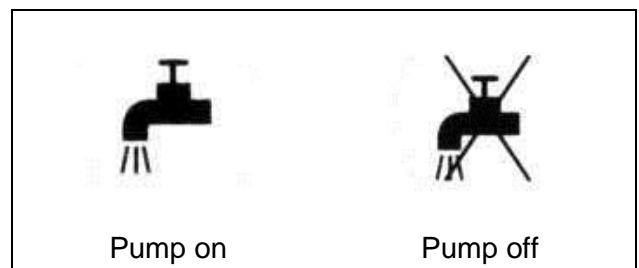
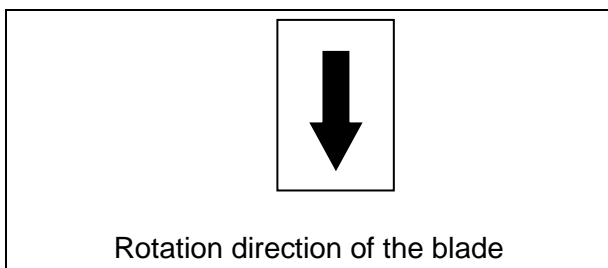
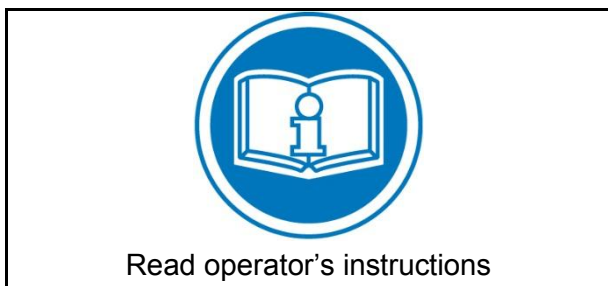

1.2 Machine plate

Important data can be found on the following plate located on the machine:

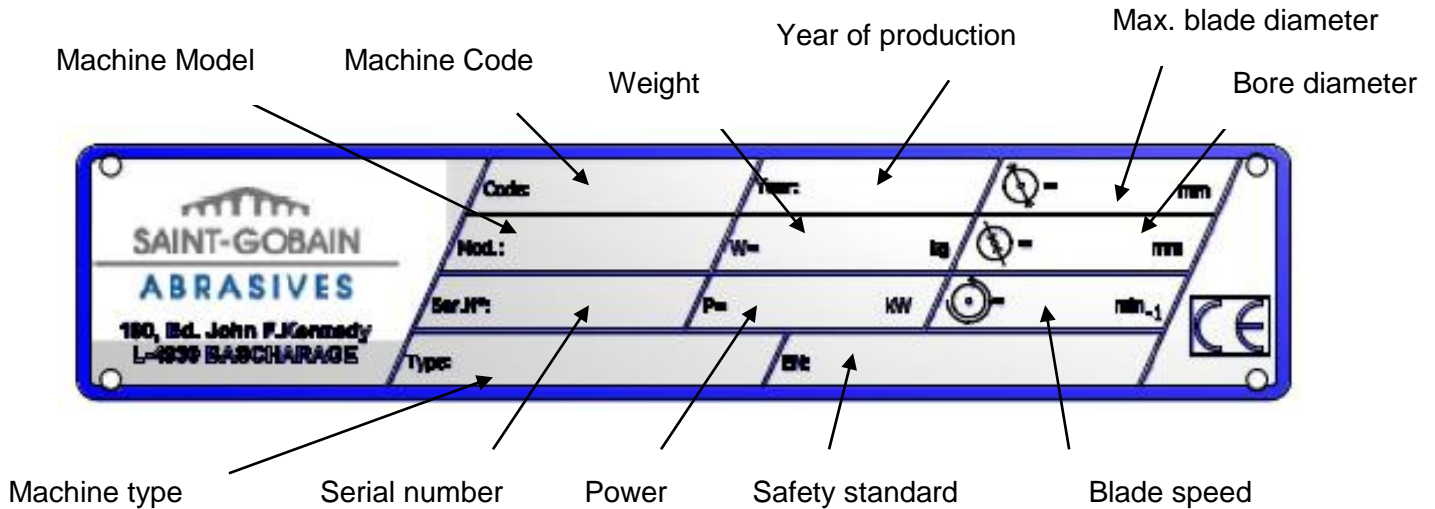

1.3 Safety instructions for particular operating phases

Before commencing work

- Before commencing work, make yourself familiar with the working environment at the place of use. The working environment includes: obstacles in the area of work and manoeuvre, the firmness of the floor, necessary protection at the site relating to public thoroughfares and the availability of help in the event of accidents.
- Site the machine on an even, firm and stable base!
- Check for correct mounting of the blade regularly.
- Immediately remove damaged or badly worn blades, as they endanger the operator whilst rotating.
- The material to be cut must be held securely in place on the table to allow no unexpected movement during cutting operation.
- Always cut with the blade guard in position.
- Only fit NORTON CLIPPER diamond blades with continuous rim to the machine! The use of other tools can damage the machine!
- Read the blades' specifications carefully to choose the correct tool for your application.
- Attention is drawn to the use of BS2092 safety goggles in conformity with specified Processes No.8 of the Protection of Eyes Regulation 1974, Regulation 2(2) Part 1.

Electrical powered machine

- Always turn off the machine and separate it from the main source of electricity before any work on the machine is done.
- Make all electrical connections securely to eliminate contact of live wires with spray water or dampness
- When the machine is used with water, it is **IMPERATIVE** that you earth the machine properly. Let a qualified electrician check in case of doubt.
- In case of emergency, you can stop the machine by pushing on the front cover of the switch.
- In the event of the machine breaking down or stopping for no apparent reason, switch off the main electricity supply. Only a qualified electrician is allowed to investigate the trouble and remedy the fault.

2 Machine description

Any modification, which could lead to a change in the original characteristics of the machine, may be done only by Saint-Gobain Abrasives who shall confirm that the machine is still in conformity with the safety regulations.

2.1 Short description

The TT250G Tile saw is designed for durability and high performance for onsite wet and dry cutting operations of a wide range of tiles.

As with all other CLIPPER products, the operator will immediately appreciate the attention given to detail and quality of materials used in construction. The machine and its component parts are assembled to high standards assuring long life and minimum maintenance.

2.2 Purpose of use

The machine is designed for wet and dry cutting of a large range of tiles. It is not designed for cutting wood or metals.

2.3 Layout

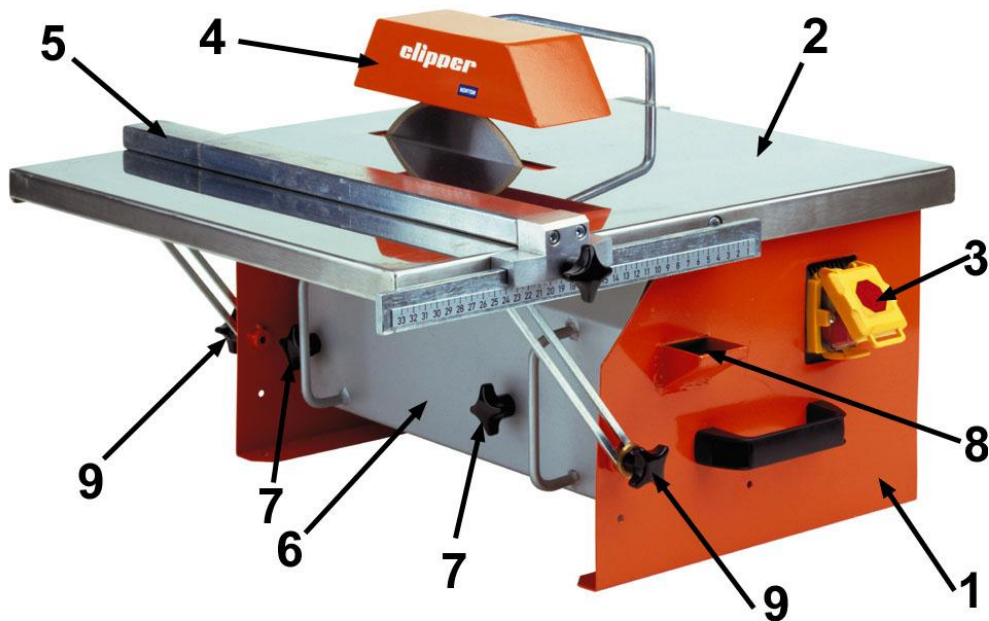

Frame (1)

The frame is made of a jig-welded reinforced steel construction to ensure perfect rigidity. It supports the motor, the cutting table and the switch.

Cutting table (2)

Stainless steel top for an excellent resistance to corrosion with engraved measurements for precise guide-a-cut alignment.

Electrical Motor and switch (3)

1kW motor. The ON-OFF switch also serves as emergency stop.

Blade guard (4)

Jig-welded steel construction with 250mm-diameter blade capacity, which offers maximum operator protection and increased visibility of the work piece. The guard is assembled on the frame.

Guide-a-cut (5)

The guide-a-cut can be adjusted to the desired cutting width. It is locked using two screws.

Water tank (6)

The blade is cooled by turning inside the water tank (7) located under the working table. The water also minimises the dust generation and improves quality of cut. It can be taken out of the machine by unscrewing the two nuts (7). An opening (8) in the frame allows the tank to be refilled easily.

Bevel cut

You can make bevel cuts with the machine by loosening the two screws (9) and pivoting the table.

2.4 Technical Data

Electric motor	1000W
Voltage	220V (machine code 70184625705 / 70184626965 for UK) 110V (machine code 70184627049)
Protection rating	IP 54
Max. blade diameter	250 mm
Bore	25,4 mm
Rotation speed of the blade	2950 min ⁻¹
Flange diameter	90 mm
Cutting depth mm	55 mm
Sound pressure level	71 dB (A) (ISO EN 11201)
Sound energy level	79 dB (A) (ISO EN 3744)
Table dimension (LxW)	560x500 mm
Machine dimensions (LxWxH)	620x600x355 mm
Weights	
Machine cpl.	26 kg
Ready for use (with water)	28 kg

3 Assembly and commissioning

The machine is delivered fully equipped. It is ready for operation after assembly the diamond blade, the blade guard and the guide-a-cut, and after connection to the appropriate power supply.

3.1 Tool assembly

Only NORTON CLIPPER continuous rim blades with a maximum diameter of 250 mm can be used with the TT250G.

All tools used must be selected with regard to their maximum permitted cutting speed for the machine's maximum permitted rotation speed.

Before mounting a new blade into the machine, switch off the machine and isolate it from the main source of electricity.



To mount a new blade, follow these steps:

- Loosen the two screws (1) on the side of the machine and remove the water tank.
- Loosen the hexagonal nut (3) on the blade shaft with the 19mm wrench (Caution: left threaded), which holds the removable outer flange.
- Remove the outer flange.
- Clean the flanges and blade shaft and inspect for wear.
- Mount the blade on shaft ensuring that direction of rotation is correct (check with the arrow on the blade guard). Wrong direction of rotation blunts the blade quickly.
- Replace outer blade flange.
- Tighten hexagonal nut.
- Reassemble the water tank in the frame, and retighten the two screws (1).

The blade bore must correspond exactly to the diameter of the blade shaft. Cracked or damaged bore is dangerous for the operator and for the machine.

3.2 *Blade guard assembly*

- The blade guard is not assembled in factory to prevent it from being damaged during transport.
- Assemble the blade guard on the support (1)



3.3 *Guide-a-cut assembly*

- Put the guide-a-cut on the table.
- Screw the two locking screws.

3.4 *Electrical connections*

Check that,

- the voltage/phase supply corresponds to the information indicated on the motor plate.
- Available power supply must have ground connection in conformity with safety regulations.
- The connecting cables should have at least a 2.5mm²-section per phase.

3.5 *Starting the machine*

Open the cover on the switch and press the green button to start the machine. Either press on the red button or directly on the switch cover to stop the machine.

3.6 *Water cooling system*

- Fill the water pan with clean water to the small hole drilled into the plastic water tray.
- Ensure that water is delivered adequately to both sides of the blade, as insufficient water supply may result in premature failure of the diamond blade.
- Always make sure that there is enough water in the pan and refill if necessary.
- In case of frost, empty the water cooling system from its water.

4 Transport and storing

4.1 Securing for transport

Before transporting the machine, always remove the blade and empty the water pan.

4.2 Long period of inactivity

If the machine is not going to be used for a long period, please take the following measures:

- Completely clean the machine
- Empty the water system

The storage site must be clean, dry and at a constant temperature.

5 Operating the machine

5.1 Site of work

5.1.1 Siting the machine

- Remove from the site anything, which might hinder the working procedure!
- Make sure the site is sufficiently well lit!
- Observe manufacturer's conditions for connecting to power supplies!
- Place electric cables in such a way that damage by the device is excluded!
- Make sure you have a continual adequate view of the working area so you can intervene in the working process at any time!
- Keep other staff out of the area, so you can work securely.

5.1.2 Space required for operation and maintenance

Leave 2 m in front of the machine and 1,5 m around it for usage and maintenance of the TT250G.

5.2 Cutting methods

To use the machine correctly, you must face it with the two hands on the tile to be cut, pushing the tile against the blade. Always keep your hands away from the moving blade.

5.3 Bevel cut



- Loosen the two screws (1) on each side of the machine.
- Pivot the table until you reach the desired angle.
- Fix the table with the screws (1). Adjust the distance to blade in regard to the tile to be cut.

5.4 General advice for the cutting

- Tiles can be cut with the machine. Before commencing work make sure tools are firmly seated!
- Select the right tools as recommended by the manufacturer depending on the material to be worked, the working procedure (dry or wet cut) to be carried out and the required efficiency.
- Make sure the water pan contains enough water.
- Set the guide-a-cut to the desired width of cut, using the two engraved measurements to align it correctly.
- Do not force on the motor. This machine is designed for a continuous use.

6 Maintenance and servicing

To ensure a long-term quality from the cutting with the TT250G, please follow the maintenance plan below:

		Begin of the day	During the changing of tool	End of the day or more often if required	Every week	After a fault	After a damage
Whole machine	Visual control (general aspect, watertightness)						
	Clean						
Flange and blade fixing devices	Clean						
Motor cooling fans	Clean						
Water pan	Clean						
Engine housing	Clean						
Reachable nuts and screws	Tighten up						

Maintenance of the machine

Always perform the maintenance of the machine with the machine isolated from the electrical supply.

Lubrication

The TT250G uses life-lubricated bearings. Therefore, you don't need to lubricate the machine at all.

Cleaning of the machine

Your machine will last longer if you clean it thoroughly after each day of work, especially water pan, motor and blade flange.

7 Faults: causes and cures

7.1 *Fault-finding procedures*

Should any fault occur during the use of the machine, turn it off, and isolate it from the electrical supply. Any works dealing with the electrical system or supply of the machine can only be carried out by a qualified electrician.

7.2 *Trouble-shooting guide*

Trouble	Possible source	Resolution
Motor is not running	No electricity	Check the electrical supply (fuse for example)
	Connection cable section too small	Change connection cable
	Defective connection cable	Change connection cable
	Defective switch	CAUTION : can only be solved by qualified electrician
	Defective motor	Change motor or contact motor manufacturer
No water on the blade	Not enough water in the pan	Refill the water pan

7.3 Circuit diagram

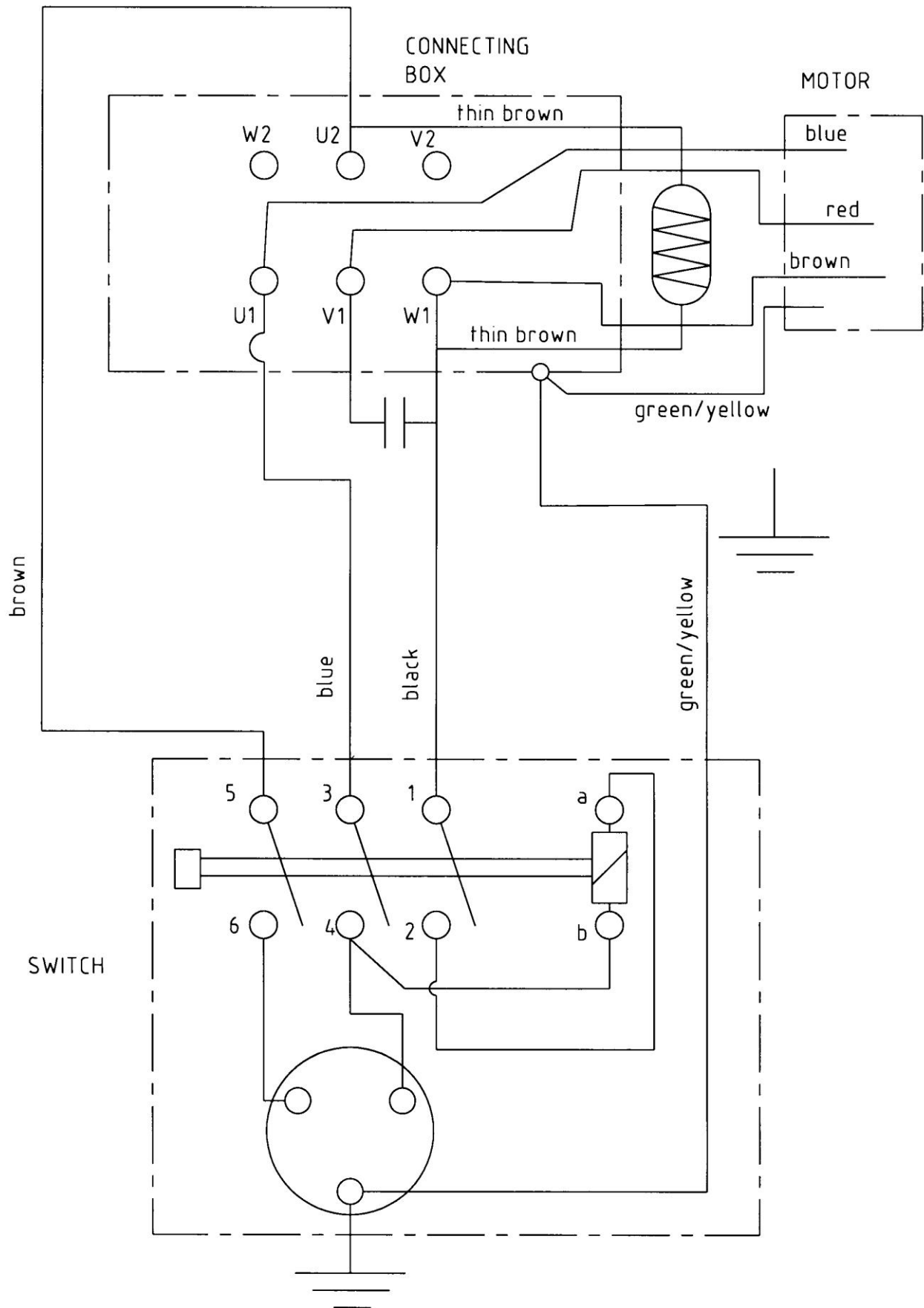

7.4 Customer service

When ordering spare parts, please mention:

- The serial number (7 digits).
- The code of the part.
- The exact denomination.
- The number of parts required.
- The delivery address.
- Please indicate clearly the means of transportation required such as "express" or "by air". Without specific instructions, we will forward the parts through the means which seem appropriate to us --- but which is not always the quickest way.

Clear instructions will avoid problems and faulty deliveries.

If not sure, please send us the defective part.

In the case of a warranty claim, the part must always be returned for evaluation.

Spare parts for the motor can be ordered with the manufacturer of the motor or with their dealer, which is often quicker and cheaper.

This machine has been manufactured by Saint-Gobain Abrasives S.A.

190, Bd J.F.Kennedy

L- 4930 BASCHARAGE

Grand-duché de Luxembourg.

Tel. : 00352-50401-1

Fax : 00352- 50 16 33

<http://www.construction.norton.eu>

e-mail: sales.nlx@saint-gobain.com

Guarantee can be claimed and technical support obtained from your local distributor where machines, spare parts and consumables can be ordered as well:

Benelux and France:

From Saint-Gobain Abrasives S.A.

Free telephone numbers:

Belgium : 0 800 18951

France: 0 800 90 69 03

Holland: 0 8000 22 02 70

e-mail: sales.nlx@saint-gobain.com

Czech Republic

Norton Diamantove Nastroje Sro

Vinohradska 184

CS-13000 PRAHA 3

Tel: 0042 0267 13 20 21

Fax : 0042 0267 13 20 21

e-mail : norton.diamonds@komerce.cz

United Kingdom

Saint-Gobain Abrasives Ltd.

Doxey Road

Staffort

ST16 1EA

Tel : 0116 2632 302

Fax : 0800 622 385

e-mail : nortondiamonduk@saint-gobain.com

Austria

Saint-Gobain Abrasives GmbH

Telsenberggasse, 37

A-5020 SALZBURG

Tel : 0043 662 43 00 76 77

Fax : 0043 662 43 01 75

e-mail: office@sga.net

Germany

Saint-Gobain Diamond Products GmbH

Birkenweg 45-49,

D-50389 WESSELING

Tel : (02236) 8911 0

Fax : (02236) 8911 30

e-mail: sales.ngg@saint-gobain.com

Spain

Saint-Gobain Abrasivos S.A.

Ctra Guipuzcoa km7,5

E-31195 BERRIOPLANO (Navarra)

Tel: 0034 948 30 3000

Fax: 0034 948 30 6042

e-mail: Comercial.sga-apa@saint-gobain.com

Poland

Saint-Gobain Diamond Products Sp.zO.O.

AL. Krakowska 110/114

PL-00-971 WARSZAWA

Tel: 0048 22 868 29 36

Tel/Fax: 0048 22 868 29 27

e-mail: norton-diamond@wp.pl

Hungary

Saint-Gobain Abrasives KFT.

Banyaleg Utca 60B

H-1225 BUDAPEST

Tel: ++36 1 371 2250

Fax: ++36 1 371 2255

e-mail: nortonbp@axelero.hu

Italy

Saint-Gobain Abrasivi S.p.A.

Via per Cesano Boscone, 4

I-20094 CORSICO-MILANO

Tel: 0039 02 44 851

Fax : 0039 024 51 01 238

e-mail : Norton.edilizia@saint-gobain.com

www.construction.norton.eu

Saint-Gobain Abrasives

190, Bd. J. F. Kennedy
L-4930 BASCHARAGE
LUXEMBOURG

Tel: ++352 50401-1

Fax: ++352 501633

e-mail: sales.nlx@saint-gobain.com