

**NORTON**

SAINT-GOBAIN

***elipper***

Transforming  
surfaces  
...and beyond

## CG 400

SPARE PART LIST

LISTE DE PIÈCES DE RECHANGE

ERSATZTEILLISTE



  
SAINT-GOBAIN

**ENGLISH**

TYPE:

S = Spare part

W = Wear part

NA = Not Available

The kits of spare parts contain all screws and bolts and the components referring itself to it.

Screws and bolts is component of standard assembly, which you can easily find at all the retailers of standard components of assembly.

All the components of standard assembly are of a quality grade 8.8.

We recommend not to use a quality grade lower than 8.8 for all the standard components of assembly.

The parts of replacements Norton CLIPPER must always be used.

Wear parts life will vary based on usage and maintenance of the machine or part. Wear parts will need to be maintained and replaced as needed. No warranty is applied to wear parts.

The components NA (Not Available) are not available in spare part.

**FRANCAIS**

TYPE :

S = Pièce de rechange

W = Pièce d'usure

NA = Non disponible

Les kits de pièces détachées contiennent toute la visserie et les composants s'y rapportant.

La visserie est un composant d'assemblage standard, que vous pouvez facilement trouver chez tous les détaillants de composants d'assemblage standards.

Tous les composants d'assemblage standard sont d'une classe de qualité 8.8.

Nous recommandons de ne pas utiliser une classe de qualité inférieure à 8.8 pour tous les composants d'assemblage standards.

Pour les pièces non standard, les pièces de remplacement doivent impérativement provenir de Norton CLIPPER.

La durée de vie des pièces d'usure varie en fonction de l'utilisation et de la maintenance de la machine ou de la pièce. Les pièces d'usure devront être entretenues et remplacées au besoin. Aucune garantie n'est appliquée aux pièces d'usure.

Les composants NA (Not Available) ne sont pas disponibles en pièce de rechange.

**DEUTSCH**

TYP:

S = Ersatzteile

W = Verschleißteile

NA = nicht verfügbare

Die definierten Ersatzteil-Set's beinhalten alle Ersatzteile wie Komponenten, Schrauben, Muttern etc.

Norm- bzw. Standardteile wie Schrauben, Muttern etc. können bei offiziellen Schrauben- sowie Komponentenhändler bezogen werden.

Alle Norm- bzw. Standardteile wie Schrauben, Muttern etc. entsprechen der Qualitäts- bzw. Festigungsklasse 8.8.

Wir empfehlen, keine Norm- bzw. Standardteile wie Schrauben, Muttern etc. unter der Qualitäts- bzw.

Festigungsklasse 8.8 einzusetzen.

Es dürfen nur geprüfte Norton CLIPPER-Ersatzteile eingesetzt werden.

Die Lebensdauer der Verschleißteile hängt von der Verwendung und Wartung der Maschine oder des Teils ab. Verschleißteile müssen gewartet und bei Bedarf ersetzt werden. Für Verschleißteile wird keine Garantie übernommen.

Ersatzteile sowie Komponenten mit dem Vermerk NA (NA=nicht verfügbar) sind nicht verfügbar.

# CG 400

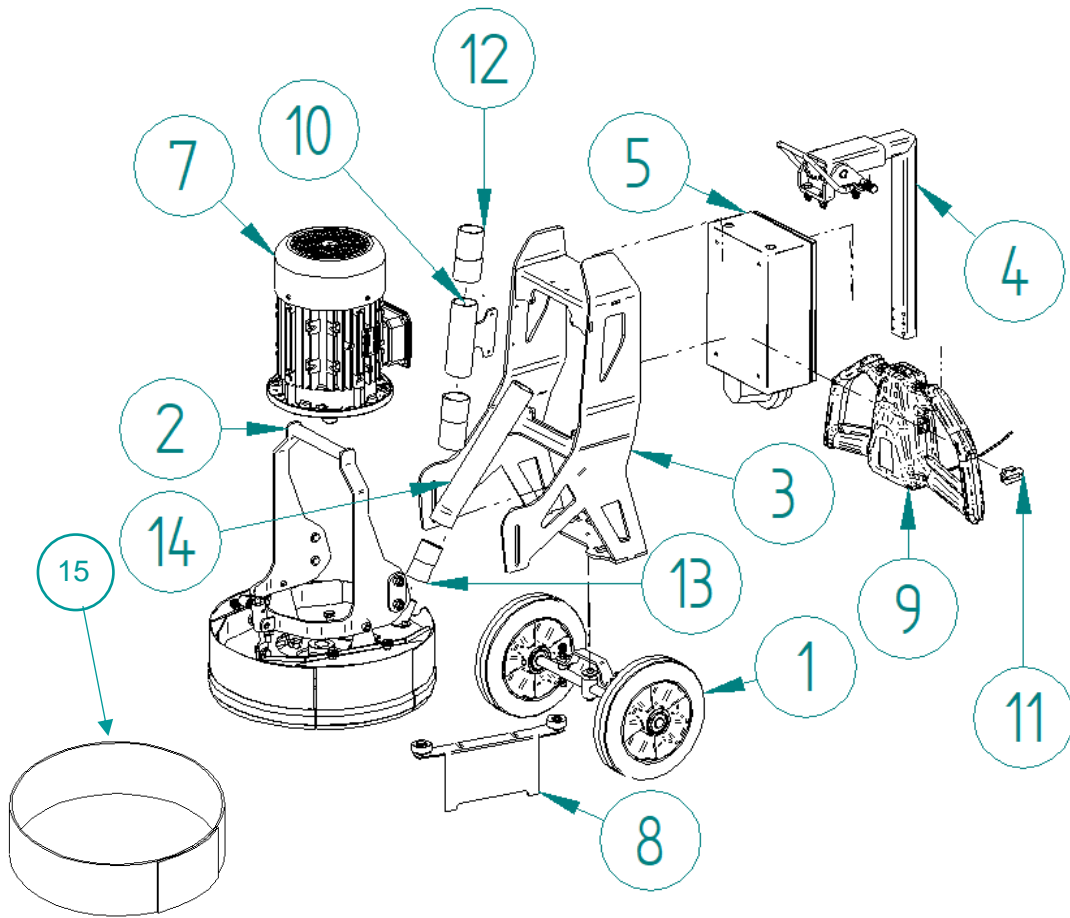

POS.	DESCRIPTION	DESCRIPTION	BESCHREIBUNG	QTY	REF	TYPE
1	BACK WHEELS CG	ROUES ARRIÈRES CG	HINTERRÄDER CG	1	310603182	S
2	SANDING HEAD CG 400	TÊTE DE PONÇAGE CG 400	SCHLEIFKOPF CG 400	1	310604498	S
3	FRAME CG	CHÂSSIS CG	RAHMEN CG	1	310603139	S
4	MACHINE CONTROL SUPPORT CG	SUPPORT COMMANDE MACHINE CG	MASCHINEN-STEUERUNGSUNTERSTÜTZUNG CG	1	310603185	S
5	ELECTRICAL CABINET CG 400	COFFRET ÉLECTRIQUE CG 400	ELEKTRISCHES SCHALTSCHRANK CG 400	1	310604500	S
6	DEAD MAN'S HANDLE CG	POIGNÉE DE COMMANDE HOMME-MORT CG	TOTMANNGRIF CG	1	310603186	S
7	ENGINE CG	MOTEUR CG	MOTOR CG	1	310604504	S
8	WALL SANDING GUIDE CG 400	GUIDE PONÇAGE RAS DE MUR CG 400	WANDKANTEN-SCHLEIFFÜHRUNG CG 400	1	310604502	S
9	SUCTION HOSE SUPPORT CG	SUPPORT DE TUYAU D'ASPIRATION CG	ABSAUGSCHLAUCHHALTERUNG CG	1	310603178	S
10	HOUR METER 230 VAC CG	COMPTEUR D'HEURES 230 VAC CG	BETRIEBSSTUNDENZÄHLER 230 VAC CG	1	310612733	S
11	FITTING CG	RACCORD CG	ANSCHLUSS CG	1	310612734	S
12	CONNECTION HOSE Ø38 CV CG	TUYAU DE RACCORDEMENT Ø38 CV CG	ANSCHLUSSSCHLAUCH Ø38 CV CG	1	310606135	S
13	FLEX TUBE D=38 L=360 MM CG	TUBE FLEXIB D=38 L=360 MM	FLEXIBLES ROHR D=38 L=360 MM CG	1	310612735	S
14	PROTECTIVE SKIRT CG 400	JUPE DE PROTECTION CG 400	SCHUTZROCK CG 400	1	310612737	S

# Sanding head CG 400 / Tête de ponçage CG 400 / Schleifkopf CG 400

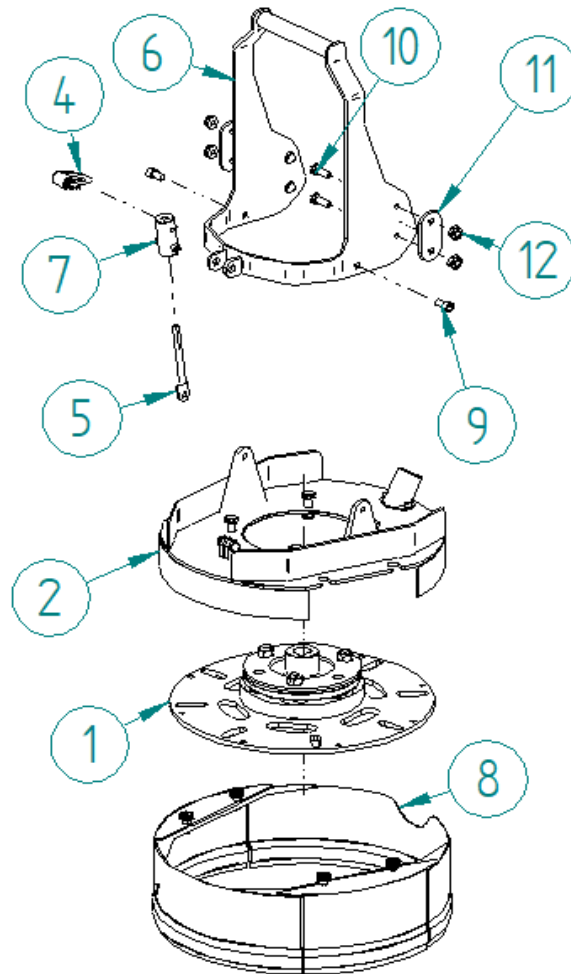

POS.	DESCRIPTION	DESCRIPTION	BESCHREIBUNG	QTY	REF	TYPE
1	TOOL HOLDER CG 400	PORTE-OUTIL CG 400	WERKZEUGHALTER CG 400	1	310604497	S
2	SUCTION SKIRT CG 400	JUPE ASPIRANTE CG 400	ABSAUGSCHÜRZE CG 400	1	310604499	S
4	M6X16 INDEXABLE HANDLE CG 400	POIGNÉE INDEXABLE M8X16 CG 400	M8X16 EINSTELLBARER GRIFF CG 400	1	310604503	S
5	ADJUSTMENT ROD CG	TIGE DE RÉGLAGE CG	EINSTELLSTANGE CG	1	310603160	S
6	MOTOR HANDLE CG 400	POIGNÉE MOTEUR CG 400	MOTORGRIFF CG 400	1	310604491	S
7	ADJUSTMENT CYLINDER CG	VÉRIN DE RÉGLAGE CG	EINSTELLZYLINDER CG	1	310603164	S
8	METAL BRUSH SKIRT CG 400	JUPE MÉTALLIQUE À POILS CG 400	METALL-BÜRSTENSCHÜRZE CG 400	1	310604501	S
9	SCREW M10X20 UNI 5931 CG	VIS M10X20 UNI 5931 CG	SCHRAUBE M10X20 UNI 5931 CG	1	310603344	S
10	SCREW M10X30 UNI 5739 CG	VIS M10X30 UNI 5739 CG	SCHRAUBE M10X30 UNI 5739 CG	1	310603345	S
11	COUNTERPLATE CG	CONTRE-PLAQUE CG	GEGENPLATTE CG	1	310603176	S
12	NUT M10 DIN 980 CG	ECROU M10 DIN 980 CG	MUTTER M10 DIN 980 CG	1	310603339	S

# Metal brush skirt CG 400 / Jupe métallique à poils CG 400 / Metallbürstenschürze CG 400

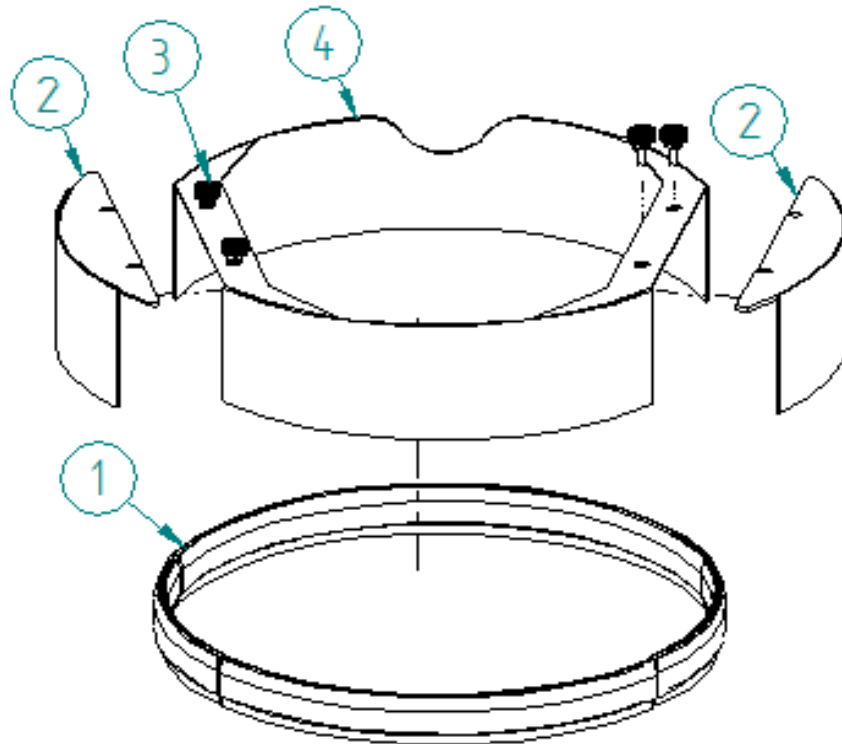

POS.	DESCRIPTION	DESCRIPTION	BESCHREIBUNG	QTY	REF	TYPE
1	BRUSH CROWN CG 400	COURONNE À POILS CG 400	BÜRSTENKROME CG 400	1	310604445	S
2	REMOVABLE PROTECTION CG 400	PROTECTION DÉMONTABLE CG 400	ABNEHMBARER SCHUTZ CG 400	1	310604444	S
3	M6X16 BUTTON SCREW CG	VIS BOUTON M6X16 CG	M6X16 KNOPFSCHRAUBE CG	1	310603188	S
4	METAL SKIRT CG 400	JUPE MÉTALLIQUE CG 400	METALLSCHÜRZE CG 400	1	310604443	S

# Back wheels / Roues arrières / Hinterräder

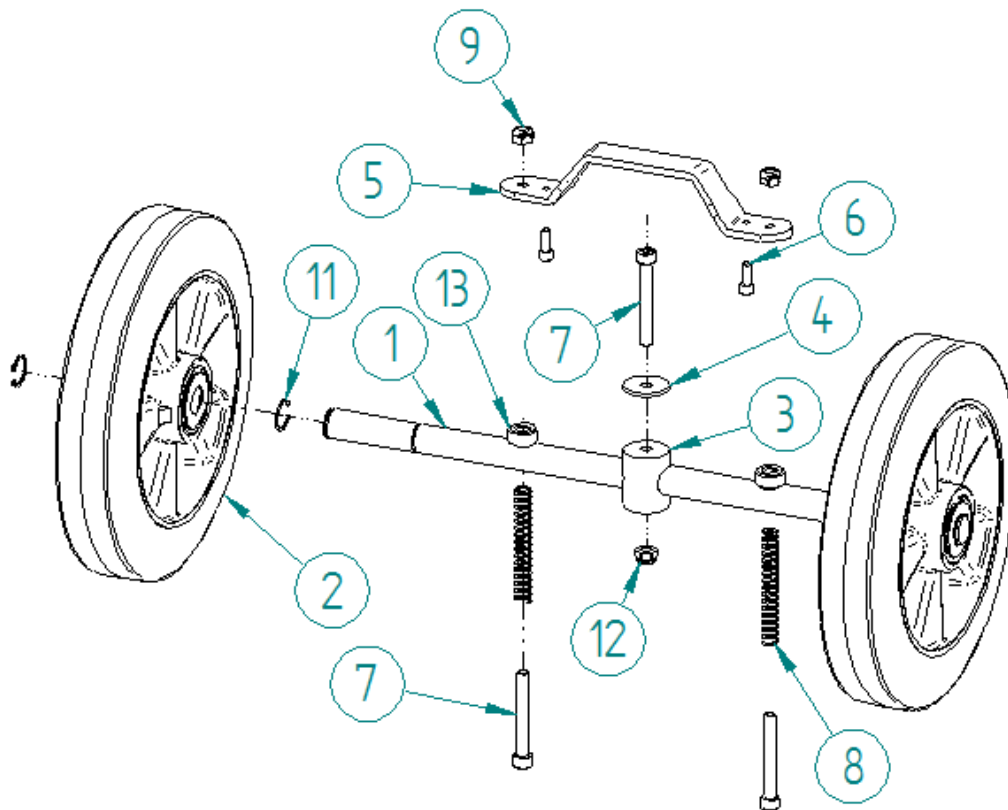

POS.	DESCRIPTION	DESCRIPTION	BESCHREIBUNG	QTY	REF	TYPE
1	WHEEL SHAFT CG	ARBRE DES ROUES CG	RADWELLE CG	1	310603140	S
2	WHEEL Ø250 CG	ROUE Ø250 CG	RAD Ø250 CG	1	310603192	S
3	CENTRAL ARTICULATION CG	ARTICULATION CENTRALE CG	ZENTRALE GELENK CG	1	310603163	S
4	WHEEL LOCKING SUPPORT CG	SUPPORT DE BLOCAGE DES ROUES CG	RADBLOCKIERUNGSUNTERSTÜTZUNG CG	1	310603341	S
5	WASHER M8 UNI 6593 CG	RONDELLE M8 UNI 6593 CG	SCHEIBE M8 UNI 6593 CG	1	310603161	S
6	SCREW M6X15 UNI 5931 CG	VIS M6X15 UNI 5931 CG	SCHRAUBE M6X15 UNI 5931 CG	1	310603350	S
7	SCREW M8X60 UNI 5931 CG	VIS M8X60 UNI 5931 CG	SCHRAUBE M8X60 UNI 5931 CG	1	310603355	S
8	SPRING CG	RESSORT CG	FEDER CG	1	310603190	S
9	NUT M8 DIN 985 CG	ÉCROU M8 DIN 985 CG	MUTTER M8 DIN 985 CG	1	310602888	S
11	Ø20 CIRCIP UNI 7435 CG	CIRCIP Ø20 UNI 7435 CG	Ø20 SICHERUNGSRING UNI 7435 CG	1	310602880	S
12	NUT M8 DIN 985 CG	ÉCROU M8 DIN 985 CG	MUTTER M8 DIN 985 CG	1	310602888	S
13	WHEEL SPACER CG	ENTRETOISE POUR ROUES CG	RADABSTANDSTÜCK CG	1	310603162	S

# Tool holder CG 400 / Porte-outil CG 400 / Werkzeughalter CG 400

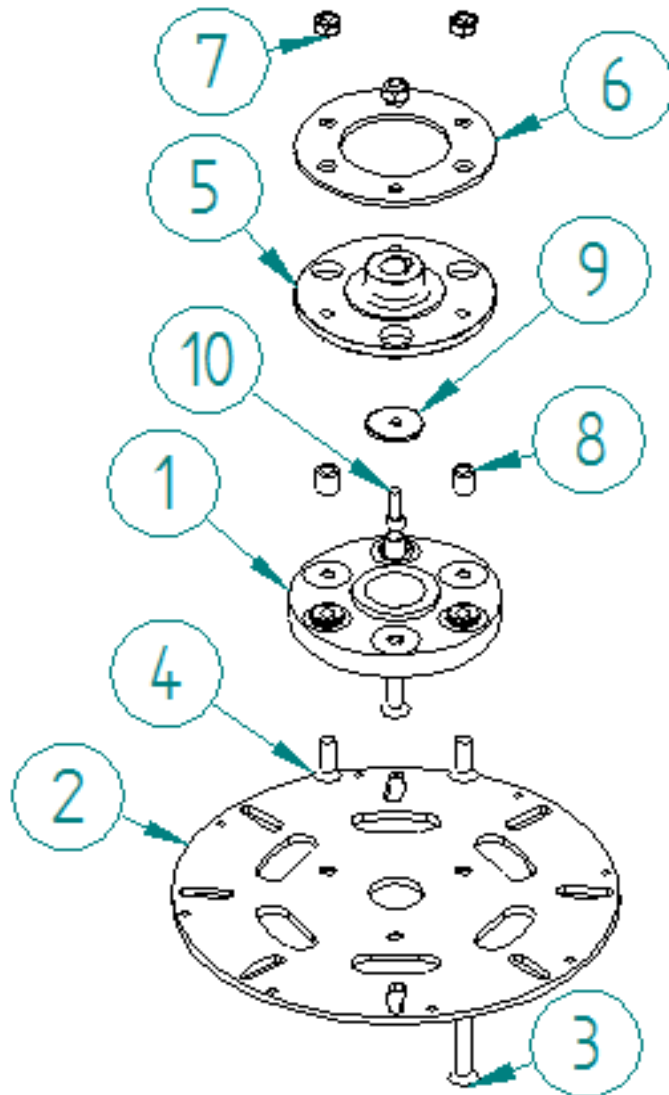

POS.	DESCRIPTION	DESCRIPTION	BESCHREIBUNG	QTY	REF	TYPE
1	LARGE SHOCK ABSORBER JOINT CG	JOINT AMORTISSEUR GRAND CG	GROÙE STOÙDÄMPFER- DICHTUNG CG	1	310603165	S
2	TOOL HOLDER DISC WITH MAGNET CG 400	DISQUE PORTE- OUTIL AVEC AIMANT CG 400	WERKZEUGHALTER SCHEIBE MIT MAGNET CG 400	1	310604488	S
3	SCREW M14X80 UNI 5933 CG	VIS M14X80 UNI 5933 CG	SCHRAUBE M14X80 UNI 5933 CG	1	310603349	S
4	SCREW M14X40 UNI 5933 CG	VIS M14X40 UNI 5933 CG	SCHRAUBE M14X40 UNI 5933 CG	1	310603348	S
5	JOINT SUPPORT DISC CG	DISQUE SUPPORT JOINT CG	DICHTUNGSUNTER- STÜTZUNGS- SCHEIBE CG	1	310603144	S
6	SAFETY DISC CG	DISQUE DE SÉCURITÉ CG	SICHERUNGS- SCHEIBE CG	1	310603141	S
7	NUT M14 UNI 5588 CG	ÉCROU M14 UNI 5588 CG	MUTTER M14 UNI 5588 CG	1	310603340	S
8	SPACER CG	ENTRETOISE CG	ABSTANDSSTÜCK CG	1	310603143	S
9	SPACER 52X11X4 CG	ENTRETOISE 52X11X4 CG	ABSTANDSSTÜCK 52X11X4 CG	1	310603145	S
10	SCREW M10X30 UNI 5931 CG	VIS M10X30 UNI 5931 CG	SCHRAUBE M10X30 UNI 5931 CG	1	310603346	S

Tool holder disc with magnet / Disque porte-outil avec aimant / Werkzeughalter Scheibe mit magnet

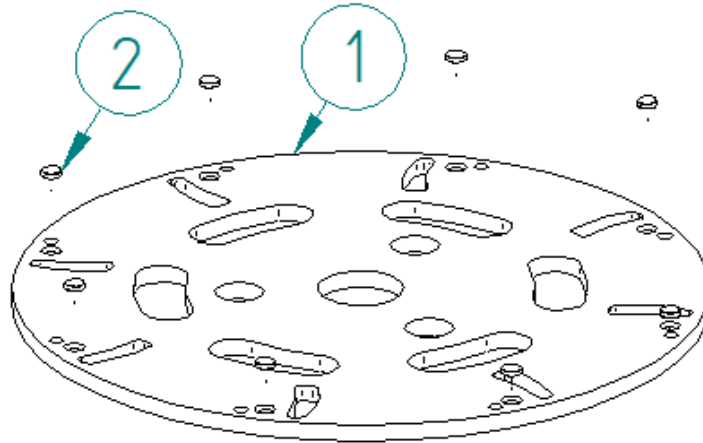

POS.	DESCRIPTION	DESCRIPTION	BESCHREIBUNG	QTY	REF	TYPE
1	TOOL HOLDER DISC CG 400	DISQUE PORTE- OUTIL CG 400	WERKZEUGHALTER SCHEIBE CG 400	1	310604490	S
2	MAGNET Ø 12 CG	AIMANT Ø12 CG	MAGNET Ø12 CG	1	310602787	S

# CG 400 suction skirt / Jupe aspirante CG 400 / CG 400 Absaugschürze

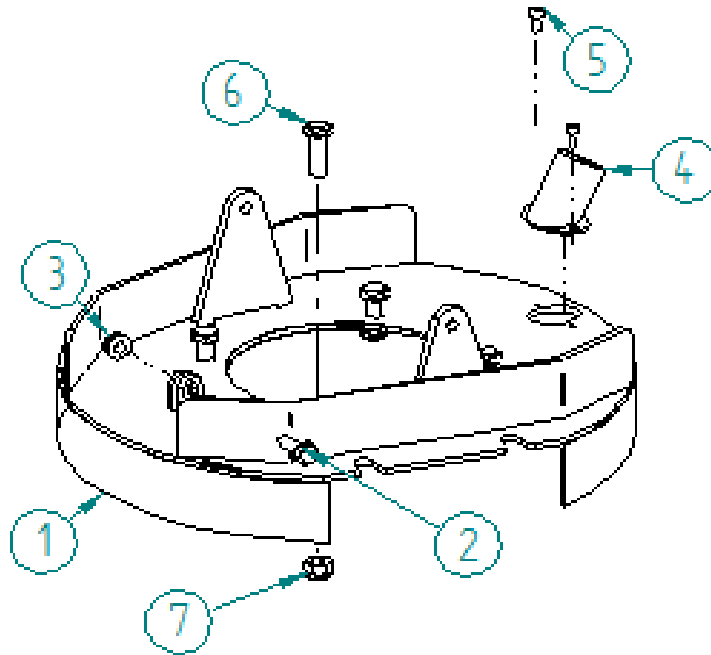

POS.	DESCRIPTION	DESCRIPTION	BESCHREIBUNG	QTY	REF	TYPE
1	PROTECTION CG 400	PROTECTION CG 400	SCHUTZ CG 400	1	310604492	S
2	SCREW M10X30 UNI 5739 CG	VIS M10X30 UNI 5739 CG	SCHRAUBE M10X30 UNI 5739 CG	1	310603345	S
3	NUT M10 DIN 985 CG	ÉCROU M10 DIN 985 CG	MUTTER M10 DIN 985 CG	1	310602881	S
4	SUCTION NOZZLE CG	EMBOUT D'ASPIRATION CG	ABSAUGDÜSE CG	1	310603173	S
5	SCREW M6X12 UNI 5931 CG	VIS M6X12 UNI 5931 CG	SCHRAUBE M6X12 UNI 5931 CG	1	310604114	S
6	SCREW M12X35 UNI 5739 CG	VIS M12X35 UNI 5739 CG	SCHRAUBE M12X35 UNI 5739 CG	1	310603784	S
7	NUT M12 DIN 985 CG	ÉCROU M12 DIN 985 CG	MUTTER M12 DIN 985 CG	1	310604505	S

# Wall sanding guide / Guide ponçage ras de mur / Wandkantenschleifführung

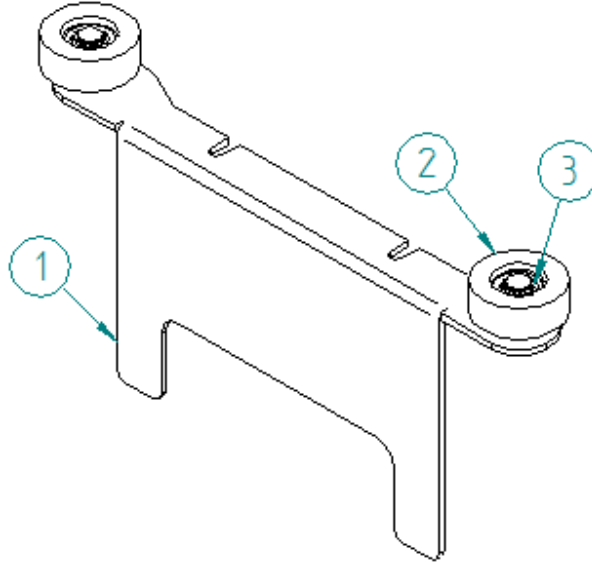

POS.	DESCRIPTION	DESCRIPTION	BESCHREIBUNG	QTY	REF	TYPE
1	WHEEL SUPPORT CG 400	SUPPORT DE ROULETTE CG 400	ROLLENHALTERUNG CG 400	1	310604496	S
2	WHEEL CG	ROULETTE CG	ROLLE CG	1	310603193	S
3	Ø10 CIRCIP UNI 7435 CG	CIRCIP Ø10 UNI 7435 CG	Ø10 SICHERUNGSRING UNI 7435 CG	1	310603338	S

# Machine control support / Support commande machine / Maschinensteuerungsunterstützung

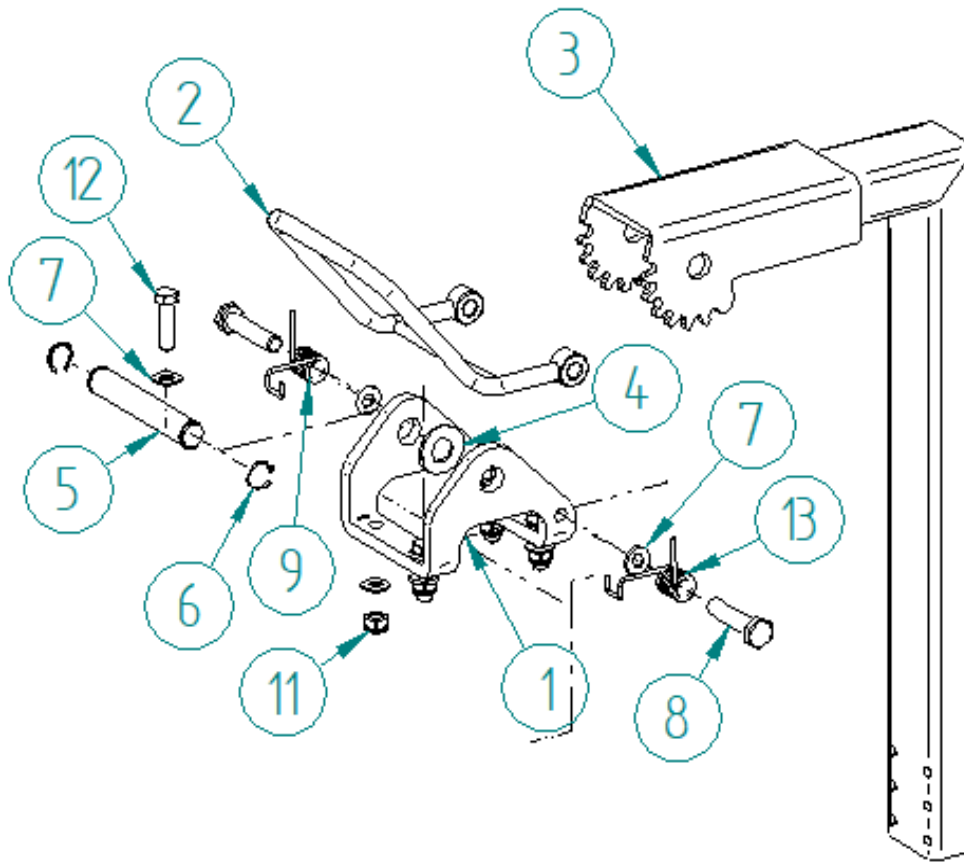

POS.	DESCRIPTION	DESCRIPTION	BESCHREIBUNG	QTY	REF	TYPE
1	CONTROL ARM SUPPORT CG	SUPPORT BRAS DE COMMANDE CG	STEUERARMSTÜTZE CG	1	310603136	S
2	ARM ADJUSTMENT HANDLE CG	POIGNÉE DE RÉGLAGE DU BRAS CG	ARMEINSTELLGRIFF CG	1	310603137	S
3	CONTROL ARM CG	BRAS DE COMMANDE CG	STEUERARM CG	1	310603177	S
4	WASHER M16 DIN 125 CG	RONDELLE M16 DIN 125 CG	SCHEIBE M16 DIN 125 CG	1	310603342	S
5	PIVOT AXLE CG	AXE PIVOT CG	PIVOTACHSE CG	1	310603138	S
6	Ø16 CIRCIP UNI 7435 CG	CIRCIP Ø16 UNI 7435 CG	Ø16 SICHERUNGSRING UNI 7435 CG	1	310603337	S
7	WASHER M8 UNI 6592 CG	RONDELLE M8 UNI 6592 CG	SCHEIBE M8 UNI 6592 CG	1	310603343	S
8	SCREW M10X60 UNI 5737 CG	VIS M10X60 UNI 5737 CG	SCHRAUBE M10X60 UNI 5737 CG	1	310603347	S
9	RIGHT TORSION SPRING CG	RESSORT DE TORSION DROIT CG	RECHTER TORSIONSFEDER CG	1	310603166	S
11	NUT M8 DIN 985 CG	ÉCROU M8 DIN 985 CG	MUTTER M8 DIN 985 CG	1	310602888	S
12	SCREW M8X30 UNI 5737 CG	VIS M8X30 UNI 5737 CG	SCHRAUBE M8X30 UNI 5737 CG	1	310603354	S
13	LEFT TORSION SPRING CG	RESSORT DE TORSION GAUCHE CG	LINKE TORSIONSFEDER CG	1	310603167	S

# Dead man's handle / Poignée de commande Homme-mort / Totmanngriff

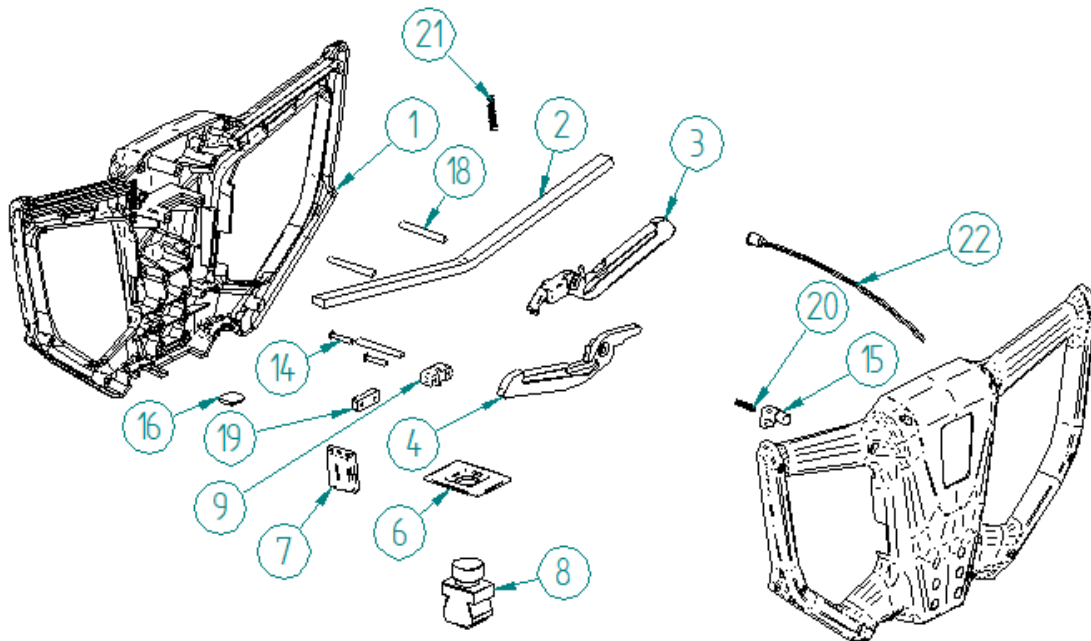

POS.	DESCRIPTION	DESCRIPTION	BESCHREIBUNG	QTY	REF	TYPE
1	DEAD MAN'S HANDLE SHELL CG	COQUE DE POIGNÉE HOMME-MORT CG	TOTMANN-GRIFFGEHÄUSE CG	1	310602731	S
2	METAL REINFORCEMENT CG	RENFORT MÉTALLIQUE CG	METALL-VERSTÄRKUNG CG	1	310602735	S
3	RIGHT START LEVER CG	LEVIER DE DÉMARRAGE DROITE CG	RECHTER STARTHEBEL CG	1	310602733	S
4	LEFT START LEVER CG	LEVIER DE DÉMARRAGE GAUCHE CG	LINKER STARTHEBEL CG	1	310602734	S
6	SWITCH SUPPORT CG	SUPPORT INTERRUPTEUR CG	SCHALTER-HALTERUNG CG	1	310602745	S
7	SIDE PLUG CG	BOUCHON LATÉRAL CG	SEITLICHER STOPFEN CG	1	310602746	S
8	SWITCH CG	INTERRUPTEUR CG	SCHALTER CG	1	310602727	S
9	CABLE BASE BLOCK CG	BLOC DE BASE DE CÂBLE CG	KABELBASISBLOCK CG	1	310602765	S
14	SCREW 4X20 UNI 9709 CG	VIS 4X20 UNI 9709 CG	SCHRAUBE 4X20 UNI 9709 CG	1	310602898	S
15	PUSH BUTTON CG	BOUCHON-POUSSOIR CG	DRUCKKNOPF CG	1	310603174	S
16	PLUG CG	BOUCHON CG	STECKER CG	1	310603175	S
18	AXIS Ø6 L=55 CG	AXE Ø6 L=55 CG	ACHSE Ø6 L=55 CG	1	310602730	S
19	CABLE BLOCK CG	BLOC CÂBLE CG	KABELBLOCK CG	1	310602771	S
20	SWITCH SPRING CG	RESSORT INTERRUPTEUR CG	SCHALTFEDER CG	1	310602774	S
21	LEVER SPRING CG	RESSORT DE LEVIER CG	HEBEL FEDER CG	1	310602775	S
22	INDICATOR LIGHT CG	VOYANT LUMINEUX CG	ANZEIGELICHT CG	1	310602788	S

SAINT-GOBAIN ABRASIVES  
 INDUSTRIEWEG 21  
 9420 ERPE-MERE  
 BELGIUM  
 TEL: +32(0) 2 267 21 00

SAINT-GOBAIN ABRASIVES, S.R.O.  
 POČERNICKÁ 272/96, MALEŠICE  
 108 00 PRAHA 10  
 CZECH REPUBLIC  
 TEL: +420 255 719 326  
 FAX: +420 255 719 321

SAINT-GOBAIN ABRASIVES A/S  
 DYBENDALSVEJENGET 2,  
 DK-2630 TAASTRUP  
 DENMARK  
 TEL: +45 4675 5244

PO BOX 643706  
 FORTUNE TOWER OFFICE 2106  
 JLT BLOCK C  
 (NEXT TO METRO STATION)  
 JUMEIRA LAKE TOWER, DUBAI  
 UNITED ARAB EMIRATES  
 TEL: +971 4 431 5154  
 FAX: +971 4 431 5434

SAINT-GOBAIN ABRASIFS  
 RUE DE L'AMBASSADEUR - B.P.8  
 78 702 CONFLANS CEDEX  
 FRANCE  
 TEL: +33 (0)1 34 90 40 00  
 FAX: +33 (0)1 39 19 89 56

SAINT-GOBAIN ABRASIVES GMBH  
 BIRKENSTRASSE 45-49  
 D-50389 WESSELING  
 GERMANY  
 TEL: +49 (0) 2236 703-0  
 FAX: +49 (0) 2236 703-730

SAINT-GOBAIN ABRASIVES KFT.  
 1225 BUDAPEST  
 BÁNYALÉG U. 60/B.  
 HUNGARY  
 TEL: +36 1 371 22 50  
 FAX: +36 1 371 22 55

SAINT-GOBAIN ABRASIVI S.P.A  
 VIA PER CESANO BOSCONI 4  
 I-20094 CORSICO MILANO  
 ITALY  
 TEL: +39 02 44 851  
 FAX: +39 02 44 78 266

SAINT-GOBAIN ABRASIVES S.A.  
 190 RUE J.F. KENNEDY  
 L-4930 BASCHARAGE  
 GRAND DUCHE DE LUXEMBOURG  
 TEL: +352 50 401 1  
 FAX: +331 83 717 792  
 NO. VERT (FRANCE): 0800 906 903

SAINT-GOBAIN ABRASIFS, S.A.  
 2 ALLÉE DES FIGUIERS  
 AIN SEBAË - CASABLANCA  
 MOROCCO  
 TEL: +212 5 22 66 57 31  
 FAX: +212 5 22 35 09 65

SAINT-GOBAIN ABRASIVES BV  
 GROENLOSEWEG 28  
 7151 HW EIBERGEN  
 P.O. BOX 10  
 7150 AA EIBERGEN  
 THE NETHERLANDS  
 TEL: +31 545 466466  
 FAX: +31 545 474605

SAINT-GOBAIN ABRASIVES AS  
 KARIHAUGVEIEN, 89  
 0186 OSLO  
 NORWAY  
 TEL: +47 63 87 06 00  
 FAX: +47 63 87 06 01

SAINT-GOBAIN HPM POLSKA SP. Z O.O.  
 UL. NORTON 1, 62-600 KOŁO  
 62-600 KOŁO  
 POLAND  
 TEL: +48 63 26 17 100  
 FAX: +48 63 27 20 401

SAINT-GOBAIN ABRASIVOS, L. DA  
 ZONA INDUSTRIAL DA MAIA  
 I-SECTOR VIII, NO. 122  
 APARTADO 6050  
 4476 - 908 MAIA  
 PORTUGAL  
 TEL: +351 229 437 940  
 FAX: +351 229 437 949

SAINT-GOBAIN GLASS  
 BUSINESS UNIT ABRASIVI  
 PUNCT DE LUCRU : LOC.VETIS, JUD.  
 SATU MARE 447355  
 STR. CAREIULUI 11  
 PARC INDUSTRIAL RENOVATIO  
 ROMANIA  
 TEL: +40 261 839 709  
 FAX: +40 261 839 710

SG HPM RUS  
 58, F. ENGELS STR.  
 STROENIE 2  
 105082 MOSCOW  
 RUSSIA  
 TEL: +74 955 408 355  
 FAX: +74 959 373 224

SAINT-GOBAIN  
 ABRASIVES (PTY) LTD  
 2 MONTEER ROAD  
 ISANDO 1600  
 P.O. BOX 67  
 SOUTH AFRICA  
 TEL: +27 11 961 2000  
 FAX: +27 11 961 2184/5

SAINT-GOBAIN ABRASIVOS, S.A.  
 CTRA. DE GUIPÚZCOA, KM. 7,5  
 E-31195 BERRIOPLANO (NAVARRA)  
 SPAIN  
 TEL: +34 948 306 000  
 FAX: +34 948 306 042

SAINT GOBAIN ABRASIVES AB  
 GÅRDSFOGDEVÄGEN 18A  
 168 66 BROMMA • SVERIGE  
 SWEDEN  
 TEL: +46 8 580 881 00  
 FAX: +46 8 580 881 30

SAINT-GOBAIN INOVATIF MALZEMELER  
 VE ASINDIRICI SAN. TIC. AS.  
 ALTAYÇEŞME MAH. ÇAMLI SOK. NO:21  
 ESAS OFIS PARK KAT:9 34843  
 MALTEPE, İSTANBUL • TURKEY  
 TEL: 0090-216-217 12 50  
 FAX: 0090-216-442 40 74

SAINT-GOBAIN ABRASIVES LTD.  
 UNICORN HOUSE UNIT 1, AMISON CLOSE  
 REDHILL BUSINESS PARK  
 STAFFORD ST161WB  
 UNITED KINGDOM  
 TEL: +44 1785 279 553  
 FAX: +44 1785 213 487



Saint-Gobain Abrasifs  
 190 Rue J.F. Kennedy  
 L-4930 Bascharage  
 Grand Duche de Luxembourg  
 Tel: +331 83717792  
 Fax: +352 50 16 33  
 no. vert (France) 0800 906 903

[www.nortonabrasives.com/fr-fr](http://www.nortonabrasives.com/fr-fr)