

NORTON

SAINT-GOBAIN

clipper

Transforming
surfaces
...and beyond

CG CLEAN 430

SPARE PART LIST

LISTE DE PIÈCES DE RECHANGE

ERSATZTEILLISTE



SAINT-GOBAIN

ENGLISH

TYPE:

S = Spare part

W = Wear part

NA = Not Available

The kits of spare parts contain all screws and bolts and the components referring itself to it.

Screws and bolts is component of standard assembly, which you can easily find at all the retailers of standard components of assembly.

All the components of standard assembly are of a quality grade 8.8.

We recommend not to use a quality grade lower than 8.8 for all the standard components of assembly.

The parts of replacements Norton CLIPPER must always be used.

Wear parts life will vary based on usage and maintenance of the machine or part. Wear parts will need to be maintained and replaced as needed. No warranty is applied to wear parts.

The components NA (Not Available) are not available in spare part.

FRANCAIS

TYPE :

S = Pièce de rechange

W = Pièce d'usure

NA = Non disponible

Les kits de pièces détachées contiennent toute la visserie et les composants s'y rapportant.

La visserie est un composant d'assemblage standard, que vous pouvez facilement trouver chez tous les détaillants de composants d'assemblage standards.

Tous les composants d'assemblage standard sont d'une classe de qualité 8.8.

Nous recommandons de ne pas utiliser une classe de qualité inférieure à 8.8 pour tous les composants d'assemblage standards.

Pour les pièces non standard, les pièces de remplacement doivent impérativement provenir de Norton CLIPPER.

La durée de vie des pièces d'usure varie en fonction de l'utilisation et de la maintenance de la machine ou de la pièce. Les pièces d'usure devront être entretenues et remplacées au besoin. Aucune garantie n'est appliquée aux pièces d'usure.

Les composants NA (Not Available) ne sont pas disponibles en pièce de rechange.

DEUTSCH

TYP:

S = Ersatzteile

W = Verschleißteile

NA = nicht verfügbare

Die definierten Ersatzteil-Set's beinhalten alle Ersatzteile wie Komponenten, Schrauben, Muttern etc.

Norm- bzw. Standardteile wie Schrauben, Muttern etc. können bei offiziellen Schrauben- sowie Komponentenhändler bezogen werden.

Alle Norm- bzw. Standardteile wie Schrauben, Muttern etc. entsprechen der Qualitäts- bzw. Festigungsklasse 8.8.

Wir empfehlen, keine Norm- bzw. Standardteile wie Schrauben, Muttern etc. unter der Qualitäts- bzw.

Festigungsklasse 8.8 einzusetzen.

Es dürfen nur geprüfte Norton CLIPPER-Ersatzteile eingesetzt werden.

Die Lebensdauer der Verschleißteile hängt von der Verwendung und Wartung der Maschine oder des Teils ab. Verschleißteile müssen gewartet und bei Bedarf ersetzt werden. Für Verschleißteile wird keine Garantie übernommen.

Ersatzteile sowie Komponenten mit dem Vermerk NA (NA=nicht verfügbar) sind nicht verfügbar.

CG CLEAN 430



POS.	DESCRIPTION	DESCRIPTION	BESCHREIBUNG	QTY	REF	TYPE
1	FRAME AND WHEEL ASSEMBLY CG CLEAN 430	ENSEMBLE CADRE ROUES CG CLEAN 430	RAHMEN- UND RADMONTAGE CG CLEAN 430	1	310604264	S
2	HOUSING ASSEMBLY CG CLEAN 430	ENSEMBLE CARTER CG CLEAN 430	GEHÄUSEMONTAGE CG CLEAN 430	1	310604265	S
3	LOWER WEIGHT ASSEMBLY CG CLEAN 430	ENSEMBLE POIDS INFÉRIEUR CG CLEAN 430	UNTERES GEWICHTS-MONTAGE CG CLEAN 430	1	310604267	S
4	20L TANK CG CLEAN 430	RÉSERVOIR 20L CG CLEAN 430	20L TANK CG CLEAN 430	1	310604221	S
5	DEAD MAN'S ARM CG CLEAN 430	BRAS HOMME-MORT CG CLEAN 430	TOTENARM CG CLEAN 430	1	310604263	S
6	HINGE PIVOT CG CLEAN 430	PIVOT CHARNIÈRE CG CLEAN 430	SCHARNIER-DREHPUNKT CG CLEAN 430	1	310604258	S
7	NON-HOWEN SUPPORT CG CLEAN 430	SUPPORT NON-HOWEN CG CLEAN 430	NICHT-HOWEN-STÜTZE CG CLEAN 430	1	310604260	S
8	STEEL PLATE CG CLEAN 430	PLAQUE ACIER CG CLEAN 430	STAHLPLATTE CG CLEAN 430	1	310604259	S
9	ANTI-TRACE RUBBER CG CLEAN 430	CAOUTCHOUC ANTI-TRACE CG CLEAN 430	ANTI-SPUR-GUMMI CG CLEAN 430	1	310604261	S
10	ELECTRICAL BOX CG CLEAN 430	COFFRET ÉLECTRIQUE CG CLEAN 430	ELEKTRISCHES GEHÄUSE CG CLEAN 430	1	310604266	S
11	ORBITAL SYSTEM MOTOR CG CLEAN 430	MOTEUR SYSTÈME ORBITAL CG CLEAN 430	ORBITALSYSYSTEM-MOTOR CG CLEAN 430	1	310604271	S
12	HEAD BLOCK PIVOT CG CLEAN 430	PIVOT BLOC TÊTE CG CLEAN 430	KOPFBLOCK-DREHPUNKT CG CLEAN 430	1	310604270	S
13	90° FEMALE CONNECTOR CG CLEAN 430	CONNECTEUR FEMELLE 90° CG CLEAN 430	90°-WEIBLICHER STECKVERBINDER CG CLEAN	1	310604218	S
14	MALE CONNECTOR ASSEMBLY CG CLEAN 430	CONNECTEUR MÂLE CPL CG CLEAN 430	MÄNNLICHER STECKVERBINDER CG CLEAN 430	1	310604217	S
15	SCREW M8X25 UNI 5931 CG	VIS M8X25 UNI 5931 CG	SCHRAUBE M8X25 UNI 5931 CG	1	310604149	S
16	WASHER M8 UNI 1751 B CG	RONDELLE M8 UNI 1751 B CG	SCHEIBE M8 UNI 1751 B CG	1	310603781	S
17	SCREW M3X8 UNI 5931 CG CLEAN 430	VIS M3X8 UNI 5931 CG CLEAN 430	SCHRAUBE M3X8 UNI 5931 CG CLEAN 430	1	310604286	S

Housing Assembly / Ensemble carter / Gehäusemontage

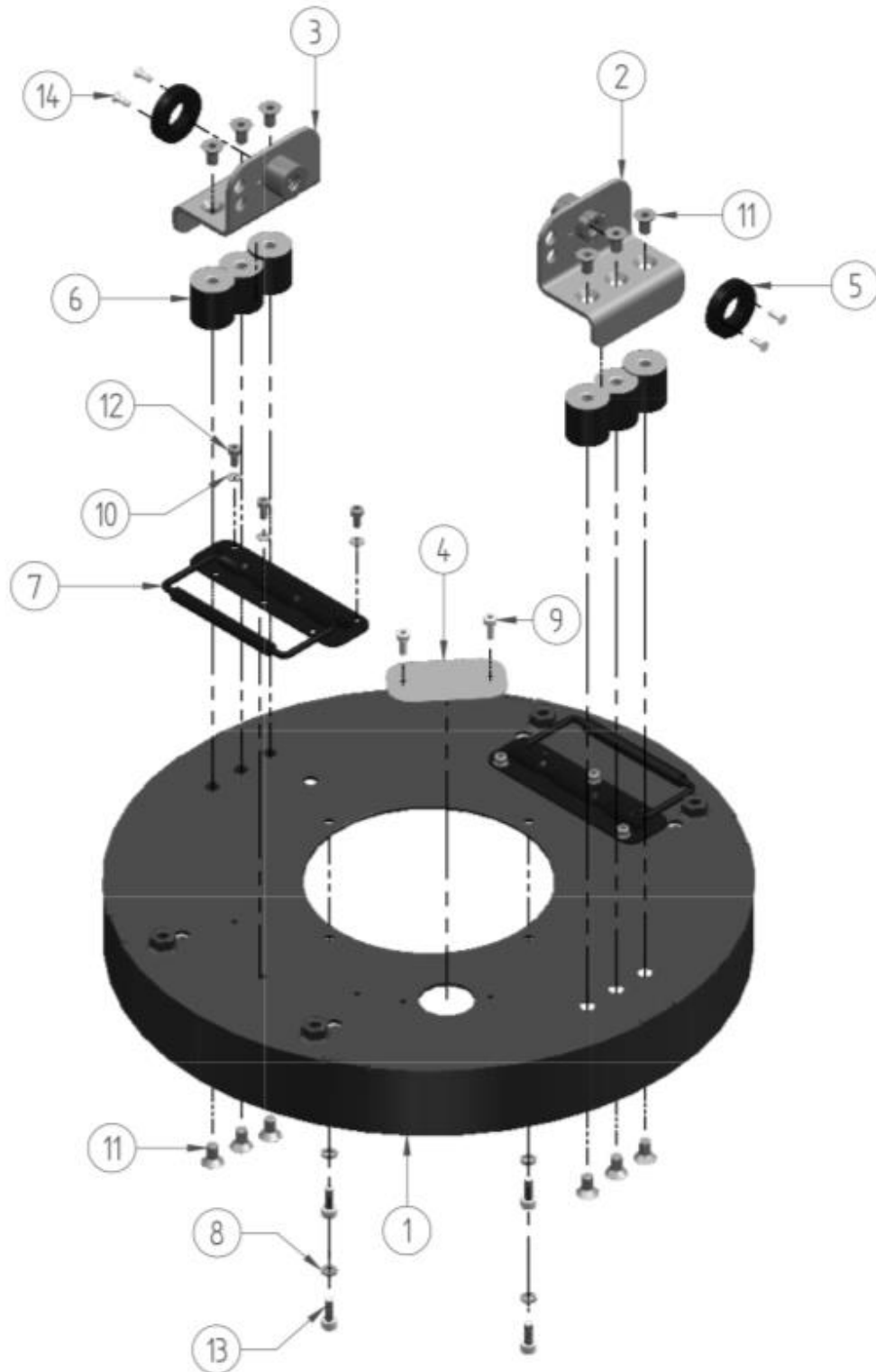

POS.	DESCRIPTION	DESCRIPTION	BESCHREIBUNG	QTY	REF	TYPE
1	HOUSING CG CLEAN 430	CARTER CG CLEAN 430	GEHÄUSE CG CLEAN 430	1	310604253	S
2	RIGHT ANTIVIBRATION SUPPORT CG CLEAN 430	SUPPORT ANTIVIBRATOIRE DROITE CG CLEAN	RECHTE ANTIVIBRATIONS-STÜTZE CG CLEAN 430	1	310604254	S
3	LEFT ANTIVIBRATION SUPPORT CG CLEAN 430	SUPPORT ANTIVIBRATOIRE GAUCHE CG CLEAN	LINKE ANTIVIBRATIONS-STÜTZE CG CLEAN 430	1	310604256	S
4	CAP CG CLEAN 430	BOUCHON CG CLEAN 430	STOPFEN CG CLEAN 430	1	310604255	S
5	ANTIVIBRATION SPACER CG CLEAN 430	ENTRETOISE ANTIVIBRATOIRE CG CLEAN 430	ANTIVIBRATIONS-ABSTANDSHALTER CG CLEAN	1	310604257	S
6	ANTIVIBRATION STUD CG CLEAN 430	PLOT ANTIVIBRATOIRE CG CLEAN 430	ANTIVIBRATIONS-STIFT CG CLEAN 430	1	310604269	S
7	HANDLE CG CLEAN 430	POIGNÉE CG CLEAN 430	GRIFF CG CLEAN 430	1	310604268	S
8	WASHER M6 UNI 6592 CG CLEAN 430	RONDELLE M6 UNI 6592 CG CLEAN 430	SCHEIBE M6 UNI 6592 CG CLEAN 430	1	310604195	S
9	SCREW M5X12 UNI 5931 CG CLEAN 430	VIS M5X12 UNI 5931 CG CLEAN 430	SCHRAUBE M5X12 UNI 5931 CG CLEAN 430	1	310604289	S
10	WASHER M5 UNI 6592 CG	RONDELLE M5 UNI 6592 CG	SCHEIBE M5 UNI 6592 CG	1	310602892	S
11	SCREW M8X15 UNI 5933 CG	VIS M8X15 UNI 5933 CG	SCHRAUBE M8X15 UNI 5933 CG	1	310604291	S
12	SCREW M5X10 UNI 5931 CG CLEAN 430	VIS M5X10 UNI 5931 CG CLEAN 430	SCHRAUBE M5X10 UNI 5931 CG CLEAN 430	1	310604288	S
13	SCREW M6X14 UNI 5931 CG	VIS M6X14 UNI 5931 CG	SCHRAUBE M6X14 UNI 5931 CG	1	310603788	S
14	SCREW M4X10 UNI 5933 CG CLEAN 430	VIS M4X10 UNI 5933 CG CLEAN 430	SCHRAUBE M4X10 UNI 5933 CG CLEAN 430	1	310604287	S

Frame and Wheel Assembly / Ensemble Cadre roues / Rahmen- und Radmontage

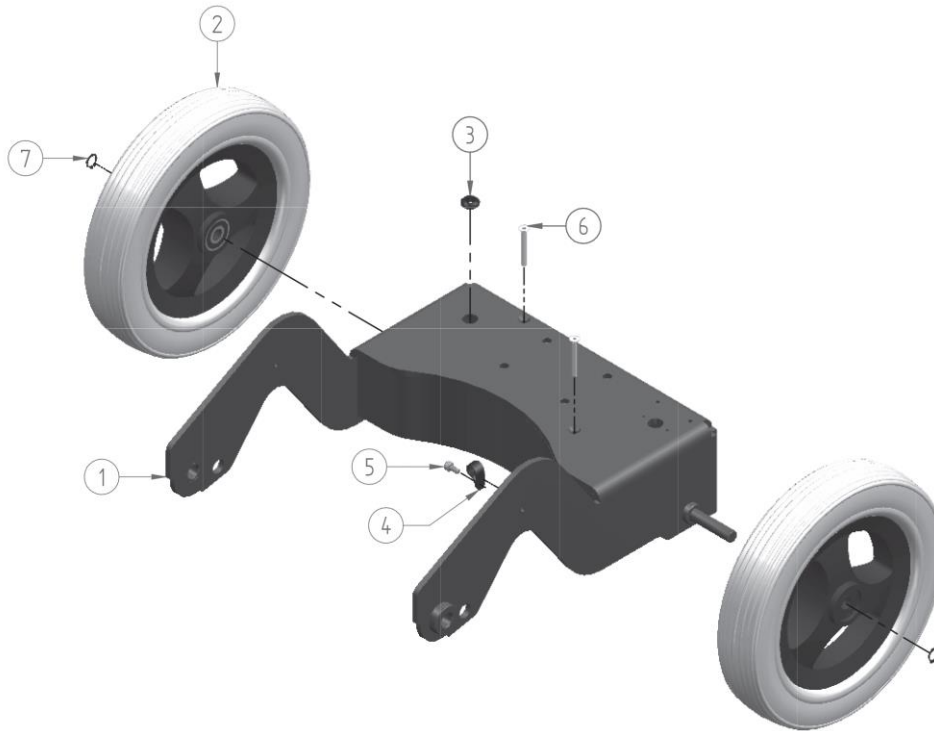

POS.	DESCRIPTION	DESCRIPTION	BESCHREIBUNG	QTY	REF	TYPE
1	FRAME CG CLEAN 430	CHÂSSIS CG CLEAN 430	GESTELL CG CLEAN 430	1	310604252	S
2	WHEEL CG	ROUE CG	RAD CG	1	310603993	S
3	CABLE GROMMET P10X13 CG CLEAN 430	PASSE-CÂBLE P10X13 CG CLEAN 430	KABELDURCHFÜHRUNG P10X13 CG CLEAN 430	1	310604272	S
4	CABLE FASTENING CLAMP CG CLEAN 430	COLLIER DE FIXATION CÂBLE CG CLEAN 430	KABELBEFESTIGUNGSKLAMMER CG CLEAN 430	1	310604216	S
5	SCREW M5X10 UNI 5931 CG CLEAN 430	VIS M5X10 UNI 5931 CG CLEAN 430	SCHRAUBE M5X10 UNI 5931 CG CLEAN 430	1	310604288	S
6	SCREW M5X45 UNI 5933 CG CLEAN 430	VIS M5X45 UNI 5933 CG CLEAN 430	SCHRAUBE M5X45 UNI 5933 CG CLEAN 430	1	310604290	S
7	Ø12 CIRCIP UNI 7435 CG CLEAN 430	CIRCIP Ø12 UNI 7435 CG CLEAN 430	Ø12 SICHERUNGSRING UNI 7435 CG CLEAN 430	1	310604194	S

20L Tank / Réservoir 20L / 20L Tank

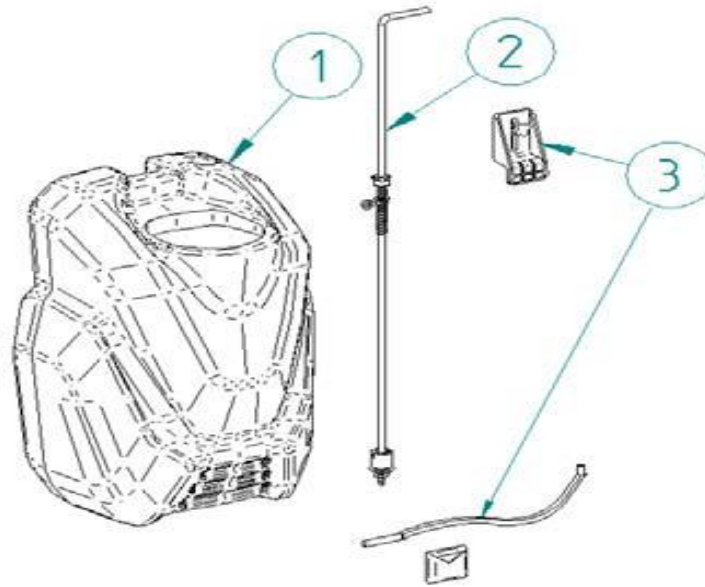

POS.	DESCRIPTION	DESCRIPTION	BESCHREIBUNG	QTY	REF	TYPE
1	NAKED 20L TANK CG CLEAN 430	RÉSERVOIR NU 20L CG CLEAN 430	NACKTER 20-LITER- TANK CG CLEAN 430	1	310604220	S
2	FAUCET KIT CG CLEAN 430	KIT DE ROBINET CG CLEAN 430	HAHN-KIT CG CLEAN 430	1	310604222	S
3	20L TANK ACCESSORIES CG CLEAN 430	ACCESSOIRES RÉSERVOIR 20 L CG CLEAN 430	ZUBEHÖR FÜR 20- LITER-TANK CG CLEAN 430	1	310604251	S

Dead Man's Arm / Bras homme-mort / Totenarm

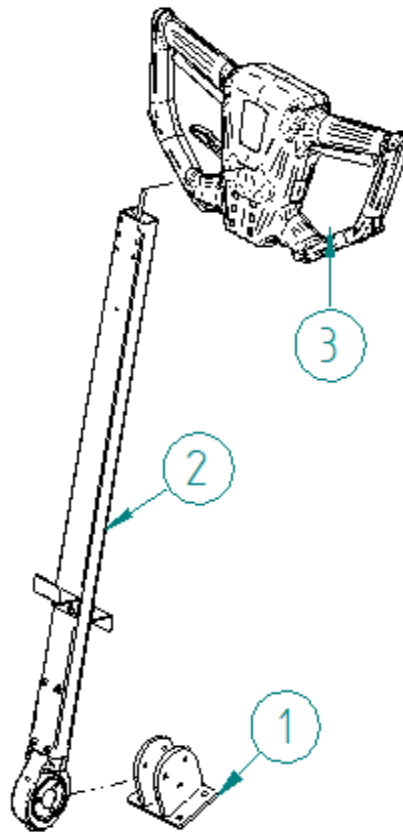

POS.	DESCRIPTION	DESCRIPTION	BESCHREIBUNG	QTY	REF	TYPE
1	SUPPORT FOR DEAD MAN'S ARM CG	SUPPORT BRAS HOMME-MORT CG	HALTERUNG FÜR TOTE-MANN-ARM CG	1	310603501	S
2	DEAD MAN'S ARM TUBE CG CLEAN 430	TUBE BRAS HOMME- MORT CG CLEAN 430	ROHR FÜR TOTE- MANN-ARM CG CLEAN 430	1	310604262	S
3	DEAD MAN'S HANDLE CG	POIGNÉE HOMME- MORT CG	TOTER-MANN-GRIFF CG	1	310602767	S

Dead man's handle / Poignée homme-mort / Toter-Mann-Griff

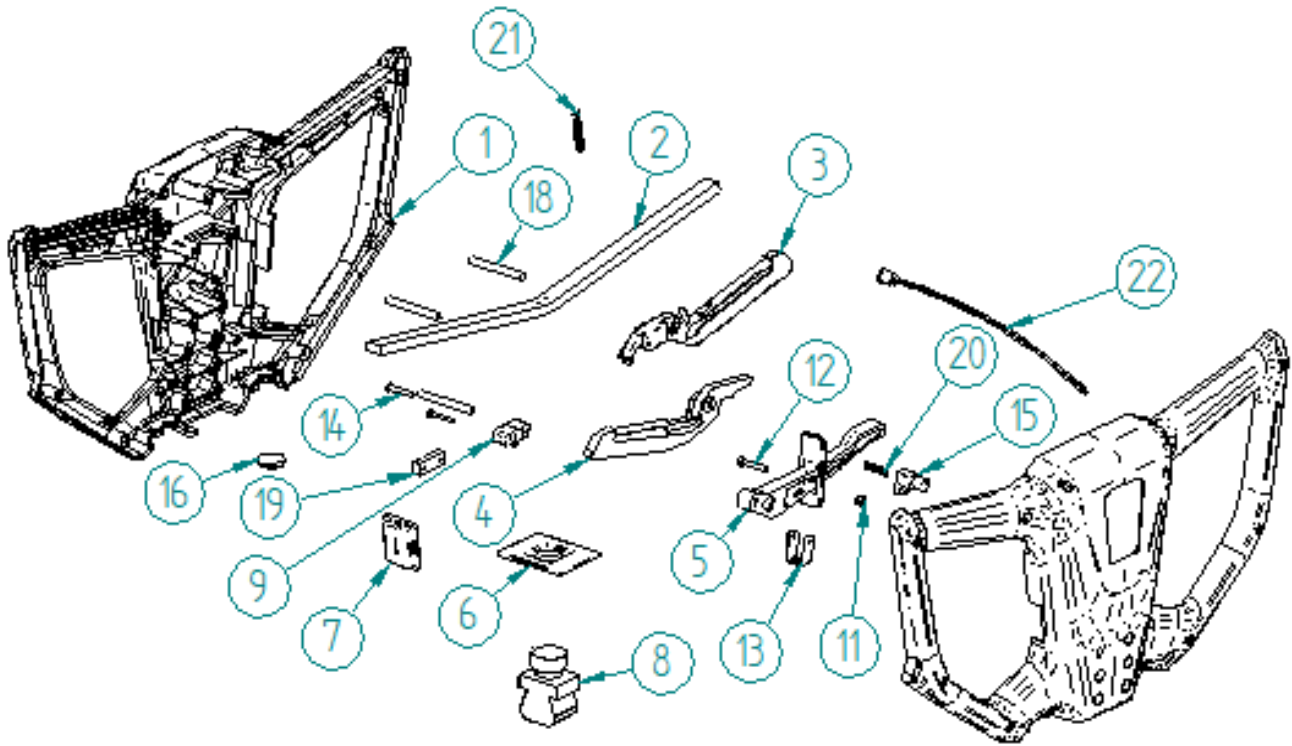

POS.	DESCRIPTION	DESCRIPTION	BESCHREIBUNG	QTY	REF	TYPE
1	DEAD MAN'S HANDLE SHELL CG	COQUE DE POIGNÉE HOMME-MORT CG	TOTMANNGRIF-GEHÄUSE CG	1	310602731	S
2	METAL REINFORCEMENT CG	RENFORT MÉTALLIQUE CG	METALL-VERSTÄRKUNG CG	1	310602735	S
3	RIGHT START LEVER CG	LEVIER DE DÉMARRAGE DROITE CG	RECHTER STARTHEBEL CG	1	310602733	S
4	LEFT START LEVER CG	LEVIER DE DÉMARRAGE GAUCHE CG	LINKER STARTHEBEL CG	1	310602734	S
5	RELEASE LEVER CG	LEVIER DE DÉVERROUILLAGE CG	ENTRIEGELUNG-SHEBEL CG	1	310602732	S
6	SWITCH SUPPORT CG	SUPPORT INTERRUPTEUR CG	SCHALTER-HALTERUNG CG	1	310602745	S
7	SIDE PLUG CG	BOUCHON LATÉRAL CG	SEITLICHER STOPFEN CG	1	310602746	S
8	SWITCH CG	INTERRUPTEUR CG	SCHALTER CG	1	310602727	S
9	CABLE BASE BLOCK CG	BLOC DE BASE DE CÂBLE CG	KABELBASISBLOCK CG	1	310602765	S
11	NUT M4 DIN 985 CG	ÉCROU M4 DIN 985 CG	MUTTER M4 DIN 985 CG	1	310602885	S
12	SCREW M4X25 UNI 5931 CG	VIS M4X25 UNI 5931	SCHRAUBE M4X25 UNI 5931	1	310602899	S
13	CABLE TIE CG	ATTACHE CÂBLE CG	KABELBINDER CG	1	310602766	S
14	SCREW 4X20 UNI 9709 CG	VIS 4X20 UNI 9709 CG	SCHRAUBE 4X20 UNI 9709 CG	1	310602898	S
15	BUTTON CG	BOUTON CG	TASTE CG	1	310602772	S
16	PLUG CG	BOUCHON CG	STOPFEN CG	1	310602773	S
18	AXIS Ø6 L=55 CG	AXE Ø6 L=55 CG	ACHSE Ø6 L=55 CG	1	310602730	S
19	CABLE BLOCK CG	BLOC CÂBLE CG	KABELBLOCK CG	1	310602771	S
20	SWITCH SPRING CG	RESSORT INTERRUPTEUR CG	SCHALTFEDER CG	1	310602774	S
21	LEVER SPRING CG	RESSORT DE LEVIER CG	HEBEL FEDER CG	1	310602775	S
22	INDICATOR LIGHT CG	VOYANT LUMINEUX CG	ANZEIGELICHT CG	1	310602788	S

SAINT-GOBAIN ABRASIVES
 INDUSTRIEWEG 21
 9420 ERPE-MERE
 BELGIUM
 TEL: +32(0) 2 267 21 00

SAINT-GOBAIN ABRASIVES, S.R.O.
 POČERNICKÁ 272/96, MALEŠICE
 108 00 PRAHA 10
 CZECH REPUBLIC
 TEL: +420 255 719 326
 FAX: +420 255 719 321

SAINT-GOBAIN ABRASIVES A/S
 DYBENDALSVÆNGET 2,
 DK-2630 TAASTRUP
 DENMARK
 TEL: +45 4675 5244

PO BOX 643706
 FORTUNE TOWER OFFICE 2106
 JLT BLOCK C
 (NEXT TO METRO STATION)
 JUMEIRA LAKE TOWER, DUBAI
 UNITED ARAB EMIRATES
 TEL: +971 4 431 5154
 FAX: +971 4 431 5434

SAINT-GOBAIN ABRASIFS
 RUE DE L'AMBASSADEUR - B.P.8
 78 702 CONFLANS CEDEX
 FRANCE
 TEL: +33 (0)1 34 90 40 00
 FAX: +33 (0)1 39 19 89 56

SAINT-GOBAIN ABRASIVES GMBH
 BIRKENSTRASSE 45-49
 D-50389 WESSELING
 GERMANY
 TEL: +49 (0) 2236 703-0
 FAX: +49 (0) 2236 703-730

SAINT-GOBAIN ABRASIVES KFT.
 1225 BUDAPEST
 BÁNYALÉG U. 60/B.
 HUNGARY
 TEL: +36 1 371 22 50
 FAX: +36 1 371 22 55

SAINT-GOBAIN ABRASIVI S.P.A
 VIA PER CESANO BOSCONI 4
 I-20094 CORSICO MILANO
 ITALY
 TEL: +39 02 44 851
 FAX: +39 02 44 78 266

SAINT-GOBAIN ABRASIVES S.A.
 190 RUE J.F. KENNEDY
 L-4930 BASCHARAGE
 GRAND DUCHE DE LUXEMBOURG
 TEL: +352 50 401 1
 FAX: +331 83 717 792
 NO. VERT (FRANCE): 0800 906 903

SAINT-GOBAIN ABRASIFS, S.A.
 2 ALLÉE DES FIGUIERS
 AIN SEBAË - CASABLANCA
 MOROCCO
 TEL: +212 5 22 66 57 31
 FAX: +212 5 22 35 09 65

SAINT-GOBAIN ABRASIVES BV
 GROENLOSEWEG 28
 7151 HW EIBERGEN
 P.O. BOX 10
 7150 AA EIBERGEN
 THE NETHERLANDS
 TEL: +31 545 466466
 FAX: +31 545 474605

SAINT-GOBAIN ABRASIVES AS
 KARIHAUGVEIEN, 89
 0186 OSLO
 NORWAY
 TEL: +47 63 87 06 00
 FAX: +47 63 87 06 01

SAINT-GOBAIN HPM POLSKA SP. Z O.O.
 UL. NORTON 1, 62-600 KOŁO
 62-600 KOŁO
 POLAND
 TEL: +48 63 26 17 100
 FAX: +48 63 27 20 401

SAINT-GOBAIN ABRASIVOS, L. DA
 ZONA INDUSTRIAL DA MAIA
 I-SECTOR VIII, NO. 122
 APARTADO 6050
 4476 - 908 MAIA
 PORTUGAL
 TEL: +351 229 437 940
 FAX: +351 229 437 949

SAINT-GOBAIN GLASS
 BUSINESS UNIT ABRASIVI
 PUNCT DE LUCRU : LOC.VETIS, JUD.
 SATU MARE 447355
 STR. CAREIULUI 11
 PARC INDUSTRIAL RENOVATIO
 ROMANIA
 TEL: +40 261 839 709
 FAX: +40 261 839 710

SG HPM RUS
 58, F. ENGELS STR.
 STROENIE 2
 105082 MOSCOW
 RUSSIA
 TEL: +74 955 408 355
 FAX: +74 959 373 224

SAINT-GOBAIN
 ABRASIVES (PTY) LTD
 2 MONTEER ROAD
 ISANDO 1600
 P.O. BOX 67
 SOUTH AFRICA
 TEL: +27 11 961 2000
 FAX: +27 11 961 2184/5

SAINT-GOBAIN ABRASIVOS, S.A.
 CTRA. DE GUIPÚZCOA, KM. 7,5
 E-31195 BERRIOPLANO (NAVARRA)
 SPAIN
 TEL: +34 948 306 000
 FAX: +34 948 306 042

SAINT GOBAIN ABRASIVES AB
 GÅRDSFOGDEVÄGEN 18A
 168 66 BROMMA • SVERIGE
 SWEDEN
 TEL: +46 8 580 881 00
 FAX: +46 8 580 881 30

SAINT-GOBAIN INOVATIF MALZEMELER
 VE ASINDIRICI SAN. TIC. AS.
 ALTAYÇEŞME MAH. ÇAMLI SOK. NO:21
 ESAS OFISPARK KAT:9 34843
 MALTEPE, İSTANBUL • TURKEY
 TEL: 0090-216-217 12 50
 FAX: 0090-216-442 40 74

SAINT-GOBAIN ABRASIVES LTD.
 UNICORN HOUSE UNIT 1, AMISON CLOSE
 REDHILL BUSINESS PARK
 STAFFORD ST161WB
 UNITED KINGDOM
 TEL: +44 1785 279 553
 FAX: +44 1785 213 487



Saint-Gobain Abrasifs
 190 Rue J.F. Kennedy
 L-4930 Bascharage
 Grand Duche de Luxembourg
 Tel: +331 83717792
 Fax: +352 50 16 33
 no. vert (France) 0800 906 903

www.nortonabrasives.com/fr-fr