

NORTON

SAINT-GOBAIN

clipper

Transforming
surfaces
...and beyond

CM 401

SPARE PART LIST
LISTE DE PIÈCES DE RECHANGE
ERSATZTEILLISTE



SAINT-GOBAIN

ENGLISH

TYPE:

S = Spare part

W = Wear part

NA = Not Available

The kits of spare parts contain all screws and bolts and the components referring itself to it.

Screws and bolts is component of standard assembly, which you can easily find at all the retailers of standard components of assembly.

All the components of standard assembly are of a quality grade 8.8.

We recommend not to use a quality grade lower than 8.8 for all the standard components of assembly.

The parts of replacements Norton CLIPPER must always be used.

Wear parts life will vary based on usage and maintenance of the machine or part. Wear parts will need to be maintained and replaced as needed. No warranty is applied to wear parts.

The components NA (Not Available) are not available in spare part.

FRANCAIS

TYPE :

S = Pièce de rechange

W = Pièce d'usure

NA = Non disponible

Les kits de pièces détachées contiennent toute la visserie et les composants s'y rapportant.

La visserie est un composant d'assemblage standard, que vous pouvez facilement trouver chez tous les détaillants de composants d'assemblage standards.

Tous les composants d'assemblage standard sont d'une classe de qualité 8.8.

Nous recommandons de ne pas utiliser une classe de qualité inférieure à 8.8 pour tous les composants d'assemblage standards.

Pour les pièces non standard, les pièces de remplacement doivent impérativement provenir de Norton CLIPPER.

La durée de vie des pièces d'usure varie en fonction de l'utilisation et de la maintenance de la machine ou de la pièce. Les pièces d'usure devront être entretenues et remplacées au besoin. Aucune garantie n'est appliquée aux pièces d'usure.

Les composants NA (Not Available) ne sont pas disponibles en pièce de rechange.

DEUTSCH

TYP :

S = Ersatzteile

W = Verschleißteile

NA = nicht verfügbare

Die definierten Ersatzteil-Set's beinhalten alle Ersatzteile wie Komponenten, Schrauben, Muttern etc.

Norm- bzw. Standardteile wie Schrauben, Muttern etc. können bei offiziellen Schrauben- sowie Komponentenhändler bezogen werden.

Alle Norm- bzw. Standardteile wie Schrauben, Muttern etc. entsprechen der Qualitäts- bzw. Festigungsklasse 8.8.

Wir empfehlen, keine Norm- bzw. Standardteile wie Schrauben, Muttern etc. unter der Qualitäts- bzw.

Festigungsklasse 8.8 einzusetzen.

Es dürfen nur geprüfte Norton CLIPPER-Ersatzteile eingesetzt werden.

Die Lebensdauer der Verschleißteile hängt von der Verwendung und Wartung der Maschine oder des Teils ab. Verschleißteile müssen gewartet und bei Bedarf ersetzt werden. Für Verschleißteile wird keine Garantie übernommen.

Ersatzteile sowie Komponenten mit dem Vermerk NA (NA=nicht verfügbar) sind nicht verfügbar.

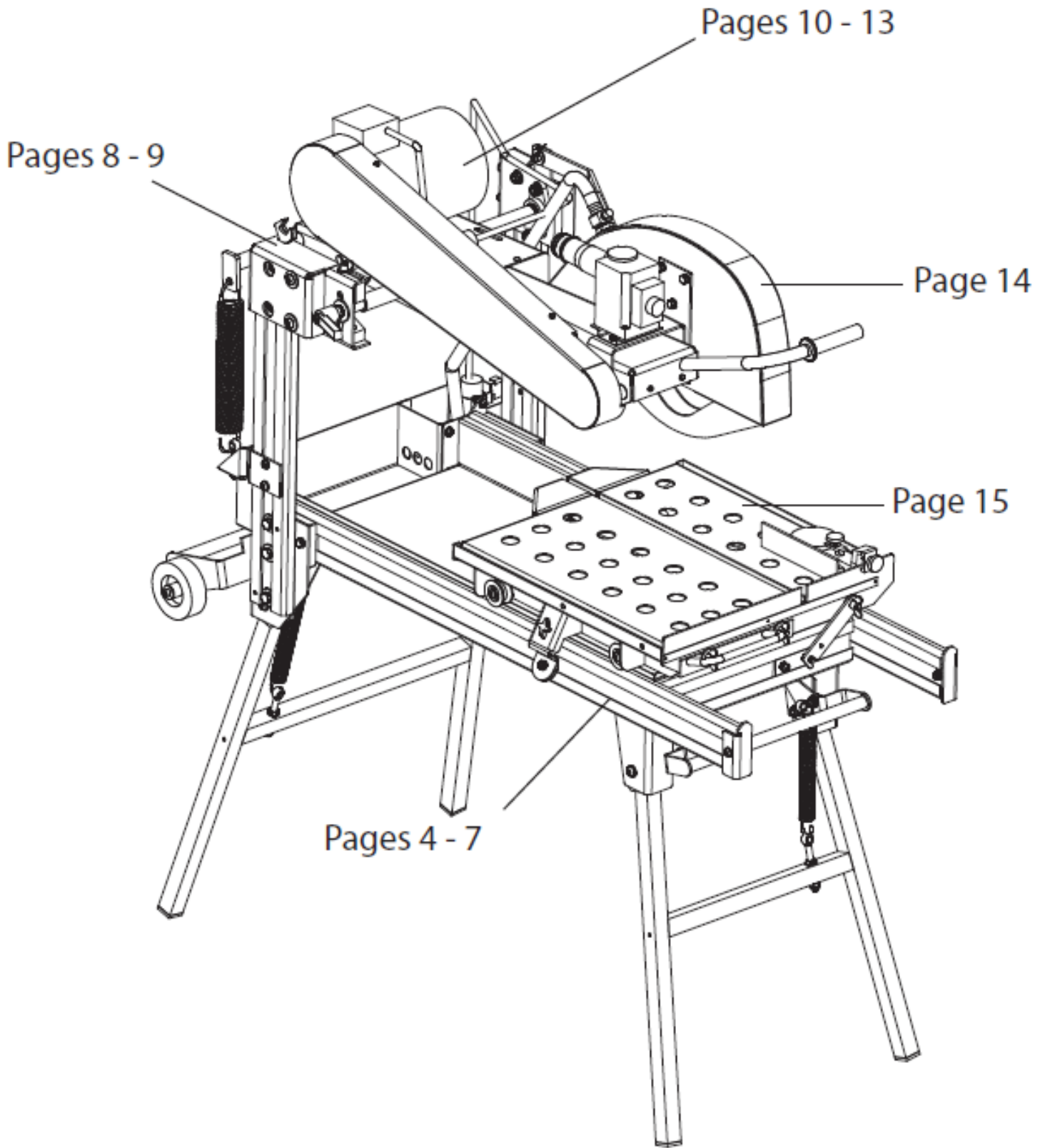

Main frame / Châssis principal / Rahmen

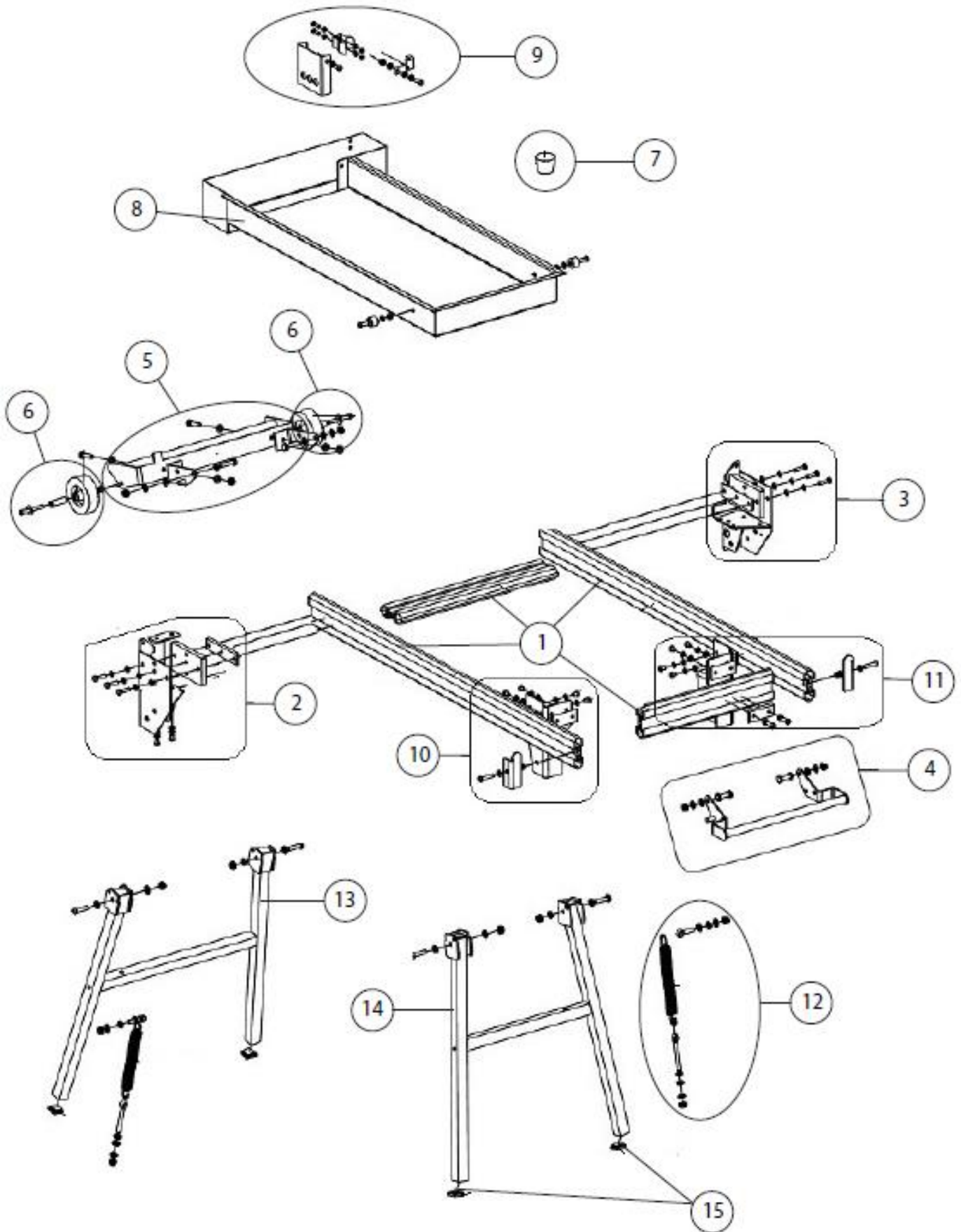

POS.	DESCRIPTION	DESCRIPTION	BESCHREIBUNG	QTY	REF	TYPE
1	Frame kit - L600 mm	Kit châssis - L600 mm	Rahmen Satz - L600 mm	1	510104003	S
	Frame	Châssis	Rahmen	1		
	screw ISO 7380 - M8X16	vis ISO 7380 - M8X16	Schraube ISO 7380 - M8X16	18		
2	Left rear corner kit	Kit coins arrières gauche	Linke Hinterecke Satz	1	310487317	S
	Sheet of fixing	Tôle de fixation	Befestigungsblech	1		
	screw ISO 7380 - M8X16	vis ISO 7380 - M8X16	Schraube ISO 7380 - M8X16	5		
	washer DIN 125 - A8,4	rondelle DIN 125 - A8,4	Scheibe DIN 125 - A8,4	5		
	washer DIN 6798A - A8	rondelle DIN 6798A - A8	Scheibe DIN 6798A - A8	5		
3	Right rear corner kit	Kit coin arrière droit	Rechte Hinterecke Satz	1	310487318	S
	Sheet of fixing	Tôle de fixation	Befestigungsblech	1		
	screw ISO 7380 - M8X16	vis ISO 7380 - M8X16	Schraube ISO 7380 - M8X16	5		
	washer DIN 125 - A8,4	rondelle DIN 125 - A8,4	Scheibe DIN 125 - A8,4	5		
	washer DIN 6798A - A8	rondelle DIN 6798A - A8	Scheibe DIN 6798A - A8	5		
4	Front handle kit	Kit poignée avant	Vorderer Handgriff Satz	1	310007290	S
	Front handle	Poignée avant	Vorderer handgriff	1		
	screw DIN 933 - M8X25	vis DIN 933 - M8X25	Schraube DIN 933 - M8X25	2		
	washer DIN 125 - A8,4	rondelle DIN 125 - A8,4	Scheibe DIN 125 - A8,4	4		
	washer DIN 6798A - A8	rondelle DIN 6798A - A8	Scheibe DIN 6798A - A8	2		
	nut DIN 985 - M8	ecrou DIN 985 - M8	Mutter DIN 985 - M8	2		
5	Rear handle kit	Kit poignée arrière	Hinterer Handgriff Satz	1	310487319	S
	Rear handle	Poignée arrière	Hinterer Handgriff	1		
	screw DIN 933 - M8X25	vis DIN 933 - M8X25	Schraube DIN 933 - M8X25	2		
	screw ISO 7380 - M8X25	vis ISO 7380 - M8X25	Schraube ISO 7380 - M8X25	2		
	washer DIN 125 - A8,4	rondelle DIN 125 - A8,4	Scheibe DIN 125 - A8,4	8		
	washer DIN 6798A - A8	rondelle DIN 6798A - A8	Scheibe DIN 6798A - A8	4		
	nut DIN 985 - M8	ecrou DIN 985 - M8	Mutter DIN 985 - M8	4		
6	Wheel kit	Kit roue	Rad Satz	1	510112315	S
	Wheel	Roue	Rad	2		
	screw ISO 7380 - M8X60	vis ISO 7380 - M8X60	Schraube ISO 7380 - M8X60	2		
	washer DIN 125 - A8,4	rondelle DIN 125 - A8,4	Scheibe DIN 125 - A8,4	4		
	nut DIN 934 - M8	ecrou DIN 934 - M8	Mutter DIN 934 - M8	2		
7	Cap	Bouchon	Stopfen	1	310004776	S
	Cap	Bouchon	Stopfen	1		
8	Water tank kit	Kit bac à eau	Wasserbehälter Satz	1	310487320	S
	Water tank	Bac à eau	Wasserbehälter	1		
	washer DIN 125 - A8,4	rondelle DIN 125 - A8,4	Scheibe DIN 125 - A8,4	4		
	screw DIN 933 - M8X50	vis DIN 933 - M8X50	Schraube DIN 933 - M8X50	2		
	nut DIN 985 - M8	ecrou DIN 985 - M8	Mutter DIN 985 - M8	2		
9	Water pump support kit	Kit support pompe à eau	Wasserpumpeträger Satz	1	310487321	S
	Water pump valve	Clapet	Wasserpumpe Klappe	1		
	Pump Support	Support pompe	Pumpeträger	1		
	screw ISO 7380 - M8X15	vis ISO 7380 - M8X15	Schraube ISO 7380 - M8X15	1		
	washer DIN 125 - A8,4	rondelle DIN 125 - A8,4	Scheibe DIN 125 - A8,4	1		
	nut DIN 934 - M8	ecrou DIN 934 - M8	Mutter DIN 934 - M8	1		
	screw DIN 933 - M6X35	vis DIN 933 - M6X35	Schraube DIN 933 - M6X35	2		
	washer DIN 125 - A6,4	rondelle DIN 125 - A6,4	Scheibe DIN 125 - A6,4	4		
	nut DIN 985 - M6	ecrou DIN 985 - M6	Mutter DIN 985 - M6	2		

Main frame / Châssis principal / Rahmen

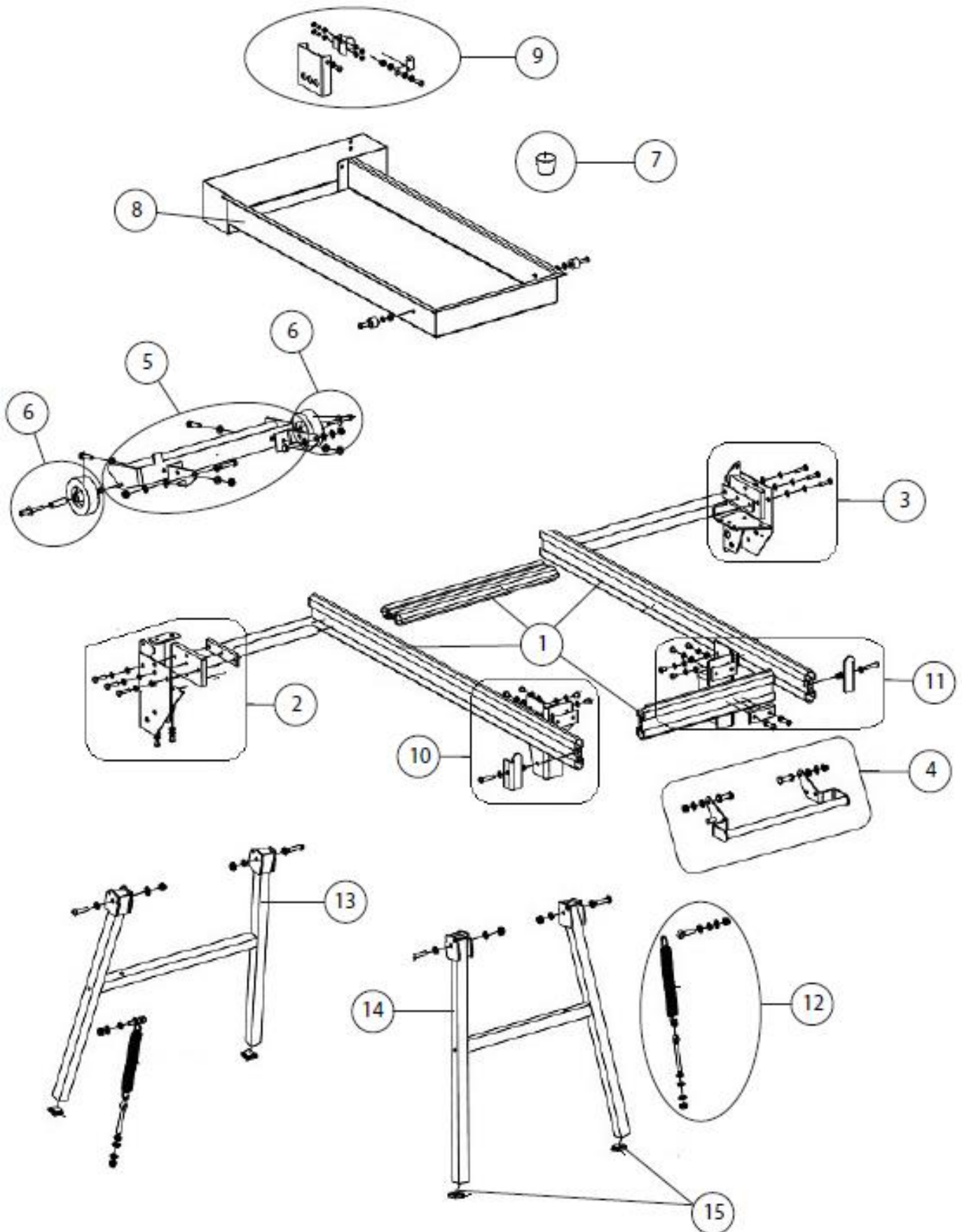

POS.	DESCRIPTION	DESCRIPTION	BESCHREIBUNG	QTY	REF	TYPE
10	Left front corner kit	Kit coin avant gauche	Linke Vorderecke Satz	1	310488081	S
	screw ISO 7380 - M8X16	vis ISO 7380 - M8X16	Schraube ISO 7380 - M8X16	6		
	washer DIN 125 - A8,4	rondelle DIN 125 - A8,4	Scheibe DIN 125 - A8,4	6		
	washer DIN 6798A - A8	rondelle DIN 6798A - A8	Scheibe DIN 6798A - A8	6		
	Sheet of fixing	Tôle de fixation	Befestigungsblech	1		
11	Right front corner kit	Kit coin avant droit	Rechte Vorderecke Satz	1	310488082	S
	screw ISO 7380 - M8X16	vis ISO 7380 - M8X16	Schraube ISO 7380 - M8X16	6		
	washer DIN 125 - A8,4	rondelle DIN 125 - A8,4	Scheibe DIN 125 - A8,4	6		
	washer DIN 6798A - A8	rondelle DIN 6798A - A8	Scheibe DIN 6798A - A8	6		
	Sheet of fixing	Tôle de fixation	Befestigungsblech	1		
12	Spring	Ressort	Feder	1	310002114	S
	Spring	Ressort	Feder	1		
	screw DIN 444 - M10X40	vis DIN 444 - M10X40	Schraube DIN 444 - M10X40	1		
	screw DIN 444 - M10X90	vis DIN 444 - M10X90	Schraube DIN 444 - M10X90	1		
	nut ISO 4035 - M10	ecrou ISO 4035 - M10	Mutter ISO 4035 - M10	2		
	washer DIN 125 - A10,5	rondelle DIN 125 - A10,5	Scheibe DIN 125 - A10,5	4		
	nut DIN 985 - M10	ecrou DIN 985 - M10	Mutter DIN 985 - M10	2		
13	Rear feet kit	Kit pied arrière	Hintere FüÙe Satz	1	310007288	S
	Rear feet	Pied arrière	Hintere FüÙe	1		
	screw DIN 444 - M10X36	vis DIN 444 - M10X36	Schraube DIN 444 - M10X36	1		
	screw DIN 444 - M10X80	vis DIN 444 - M10X80	Schraube DIN 444 - M10X80	1		
	screw ISO 7380 - M10X80	vis ISO 7380 - M10X80	Schraube ISO 7380 - M10X80	2		
	washer DIN 125 - A10,5	rondelle DIN 125 - A10,5	Scheibe DIN 125 - A10,5	8		
	washer DIN 6798A - A10	rondelle DIN 6798A - A10	Scheibe DIN 6798A - A10	4		
	NUT DIN 985 - M10	ecrou DIN 985 - M10	Mutter DIN 985 - M10	2		
14	Front feet kit	Kit pied avant	Vordere FüÙe Satz	1	310007289	S
	Front feet	Pied avant	Vordere FüÙe	1		
	screw DIN 444 - M10X36	vis DIN 444 - M10X36	Schraube DIN 444 - M10X36	1		
	screw DIN 444 - M10X80	vis DIN 444 - M10X80	Schraube DIN 444 - M10X80	1		
	screw ISO 7380 - M10X80	vis ISO 7380 - M10X80	Schraube ISO 7380 - M10X80	2		
	washer DIN 125 - A10,5	rondelle DIN 125 - A10,5	Scheibe DIN 125 - A10,5	4		
	washer DIN 6798A - A10	rondelle DIN 6798A - A10	Scheibe DIN 6798A - A10	4		
	NUT DIN 985 - M10	ecrou DIN 985 - M10	Mutter DIN 985 - M10	2		
15	Plastic cap (set of 2)	Bouchon plastique (jeu de 2)	Kunststoffstopfen Satz	1	310488818	S

Support head of cut / Support tête de coupe / Support Schüsselkopf

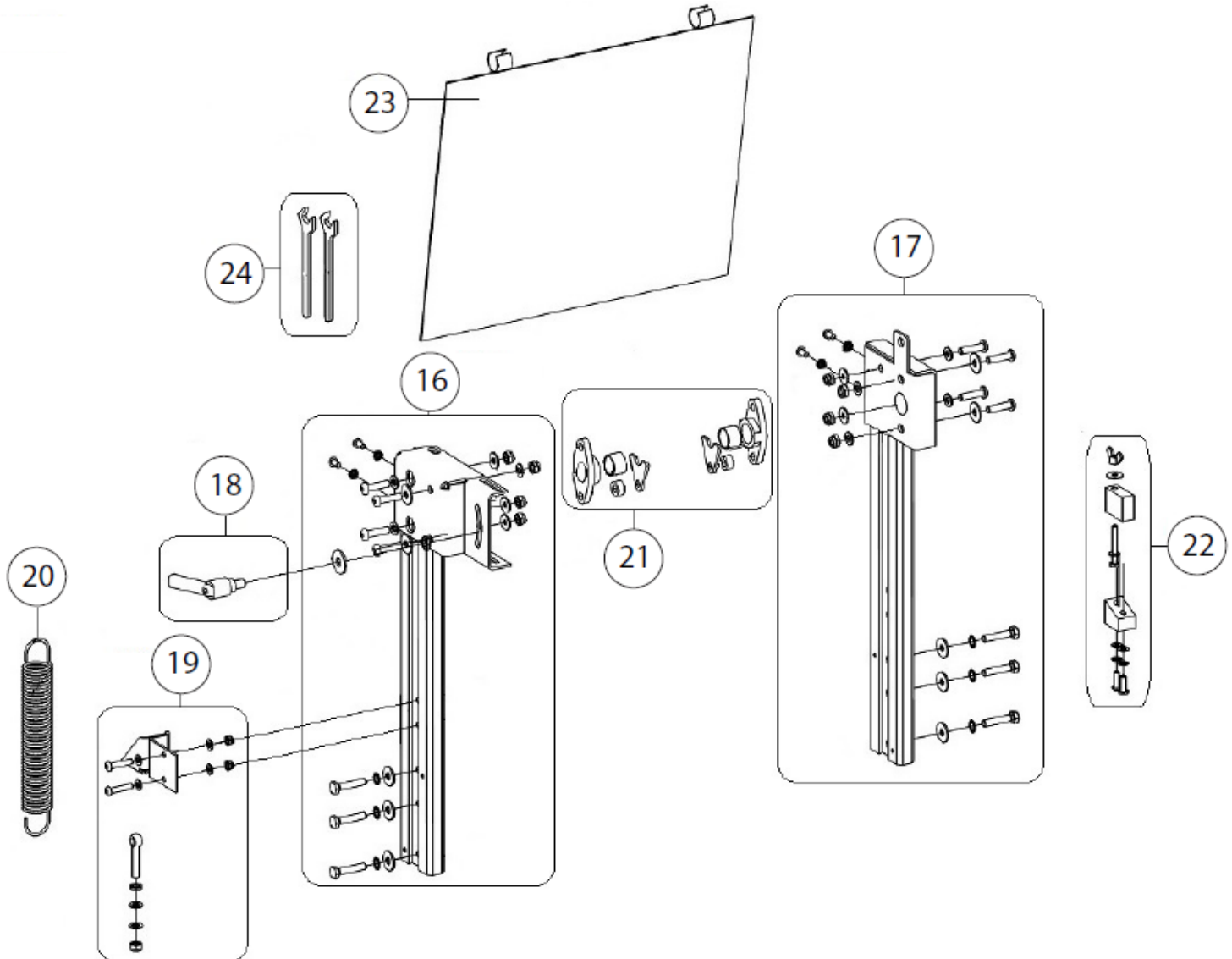

POS.	DESCRIPTION	DESCRIPTION	BESCHREIBUNG	QTY	REF	TYPE
16	Left bracket kit	Kit potence gauche	Linker Auslager Satz	1	310488083	S
	Left bracket	Potence gauche	Linker Auslager	1		
	screw ISO 7380 - M10X45	vis ISO 7380 - M10X45	Schraube ISO 7380 - M10X45	3		
	screw ISO 7380 - M10X70	vis ISO 7380 - M10X70	Schraube ISO 7380 - M10X70	4		
	screw DIN 933 - M8X25	vis DIN 933 - M8X25	Schraube DIN 933 - M8X25	2		
	washer DIN 125 - A10,5	rondelle DIN 125 - A10,5	Scheibe DIN 125 - A10,5	4		
	washer DIN 9021 - A10	rondelle DIN 9021 - A10	Scheibe DIN 9021 - A10	7		
	washer DIN 6798A - A10	rondelle DIN 6798A - A10	Scheibe DIN 6798A - A10	3		
	nut DIN 985 - M10	ecrou DIN 985 - M10	Mutter DIN 985 - M10	4		
	washer DIN 125 - A8,4	rondelle DIN 125 - A8,4	Scheibe DIN 125 - A8,4	2		
17	Right bracket kit	Kit potence droite	Richter Auslager Satz	1	310488084	S
	Right bracket	Potence droite	Richter Auslager	1		
	screw ISO 7380 - M10X45	vis ISO 7380 - M10X45	Schraube ISO 7380 - M10X45	3		
	screw ISO 7380 - M10X70	vis ISO 7380 - M10X70	Schraube ISO 7380 - M10X70	4		
	screw DIN 933 - M8X25	vis DIN 933 - M8X25	Schraube DIN 933 - M8X25	2		
	washer DIN 125 - A10,5	rondelle DIN 125 - A10,5	Scheibe DIN 125 - A10,5	4		
	washer DIN 9021 - A10	rondelle DIN 9021 - A10	Scheibe DIN 9021 - A10	7		
	washer DIN 6798A - A10	rondelle DIN 6798A - A10	Scheibe DIN 6798A - A10	3		
	nut DIN 985 - M10	ecrou DIN 985 - M10	Mutter DIN 985 - M10	4		
	washer DIN 125 - A8,4	rondelle DIN 125 - A8,4	Scheibe DIN 125 - A8,4	2		
18	Indexable handle kit	Kit poignée indexable	Indexierbarer Handgriff	1	310006528	S
	Indexable handle	Poignée indexable	Indexierbarer Handgriff	1		
19	Spring fixing kit	Kit fixation ressort	Federbefestigung Satz	1	510112476	S
	Spring fixing plate	Plaque fixation ressort	Federbefestigungsplatte	1		
	screw ISO 7380 - M8X40	vis ISO 7380 - M8X40	Schraube ISO 7380 - M8X40	2		
	screw DIN 444 - M10X50	vis DIN 444 - M10X50	Schraube DIN 444 - M10X50	1		
	washer DIN 125 - A8,4	rondelle DIN 125 - A8,4	Scheibe DIN 125 - A8,4	4		
	nut DIN 985 - M8	ecrou DIN 985 - M8	Mutter DIN 985 - M8	2		
	washer DIN 125 - A10,5	rondelle DIN 125 - A10,5	Scheibe DIN 125 - A10,5	2		
	washer DIN 6798A - A10	rondelle DIN 6798A - A10	Scheibe DIN 6798A - A10	1		
	nut DIN 985 - M10	ecrou DIN 985 - M10	Mutter DIN 985 - M10	1		
20	Spring kit	Kit ressort	Feder Satz	1	510112319	S
	Spring	Ressort	Feder	1		
21	Bearing kit	Kit palier	Lager Satz	1	510112318	S
	Bearing	Palier	Lager	2		
22	Head stop kit	Kit butée de tête	Kopfanschlag Satz	1	310007380	S
	Head stop	butée de tête	Kopfanschlag	2		
	screw DIN 933 - M8X60	vis DIN 933 - M8X60	Schraube DIN 933 - M8X60	1		
	screw ISO 7380 - M8X16	vis ISO 7380 - M8X16	Schraube ISO 7380 - M8X16	2		
	washer DIN 125 - A8,4	rondelle DIN 125 - A8,4	Scheibe DIN 125 - A8,4	4		
	washer DIN 6798A - A8	rondelle DIN 6798A - A8	Scheibe DIN 6798A - A8	2		
	nut DIN 315 - M8	ecrou DIN 315 - M8	Mutter DIN 315 - M8	1		
23	Splash guard	Rideau d'eau	Wasserspritzschutz	1	310004677	S
24	Wrench kit	Kit clé	Maulschüssel Satz	1	510112477	S
	19mm wrench	Clé 19mm	Maulschüssel 19mm	1		
	21mm wrench	Clé 21mm	Maulschüssel 21mm	1		

Cutting head / Tête de coupe / Schüsselkopf

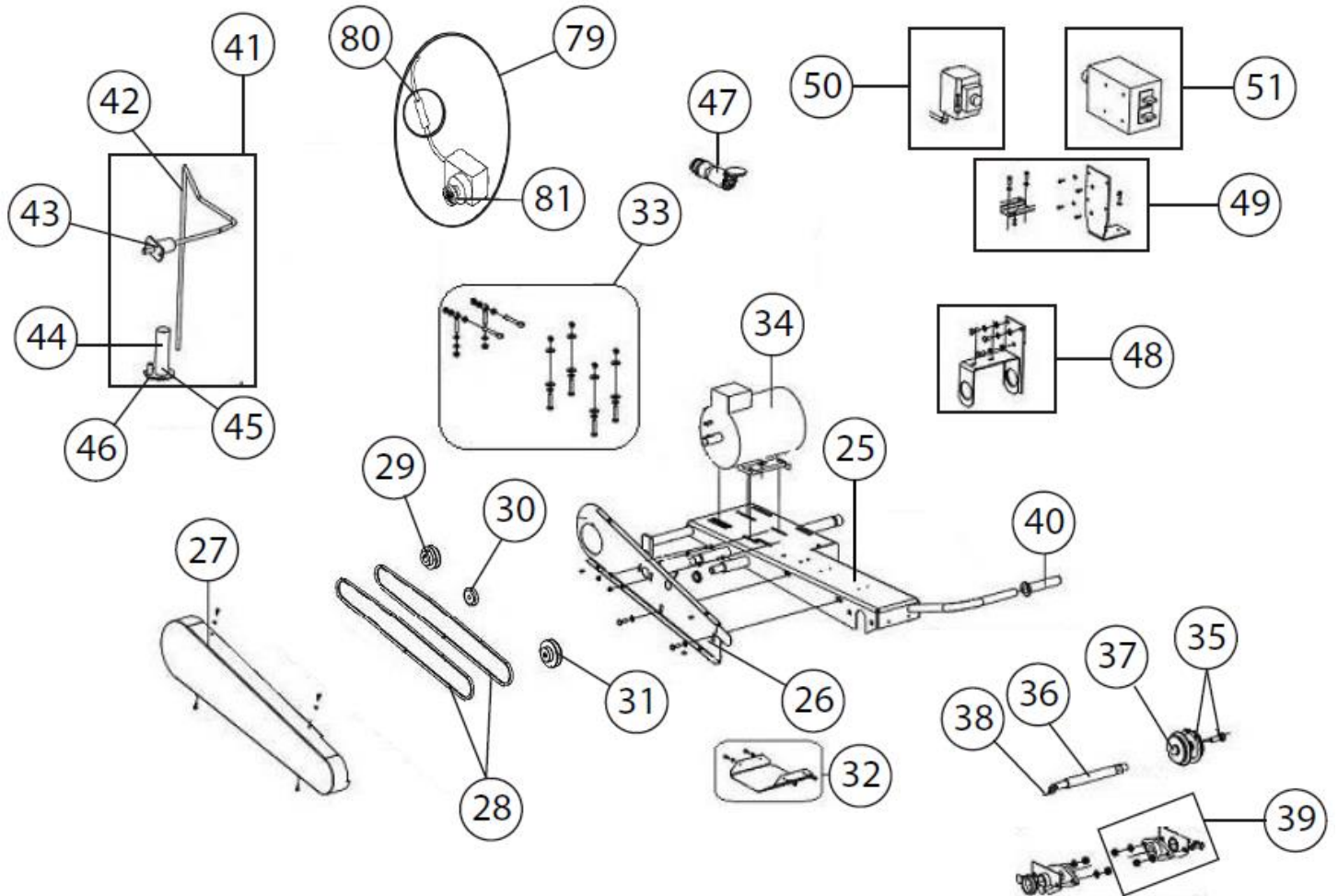

POS.	DESCRIPTION	DESCRIPTION	BESCHREIBUNG	QTY	REF	TYPE
25	Cutting head kit - Ø500 mm	Kit tête de coupe - Ø500 mm	Ø500 mm Schneidkopf Satz	1	310007382	S
	Cutting head kit - Ø600 mm	Kit tête de coupe - Ø600 mm	Ø600 mm Schneidkopf Satz	1	310007383	S
	Cutting head	Tête de coupe	Schneidkopf	1		
26	Fixed casing belt kit	Kit carter de courroie fixe	Festes Riemengehäuse Satz	1	310488796	S
	Fixed casing belt	Carter de courroie fixe	Festes Riemengehäuse	1		
	screw DIN 933 - M6X20	vis DIN 933 - M6X20	Schraube DIN 933 - M6X20	2		
	washer DIN 125 - A6,4	rondelle DIN 125 - A6,4	Scheibe DIN 125 - A6,4	2		
27	Mobile casing belt kit	Kit carter de courroie mobile	Bewegliches Riemengehäuse Satz	1	310488797	S
	Mobile casing belt	Carter de courroie mobile	Bewegliches Riemengehäuse	1		
	screw DIN 933 - M4X16	vis DIN 933 - M4X16	Schraube DIN 933 - M4X16	4		
	washer DIN 125 - A4,3	rondelle DIN 125 - A4,3	Scheibe DIN 125 - A4,3	4		
28	Belt kit 115/230V	Kit courroies 115/230V	115/230V Riemen Satz	1	310004357	W
	Belt kit 400V	Kit courroies 400V	400V Riemen Satz	1	310007389	W
	Belt	Courroie	Riemen	2		
29	Motor pulley kit 115/230V	Kit poulie moteur 115/230V	115/230V Motorrolle Satz	1	310004783	S
	Motor pulley kit 400V	Kit poulie moteur 400V	400V Motorrolle Satz	1	310004803	S
	Motor pulley	Poulie moteur	Motorrolle	1		
	Screw NF-E27-180 M8X10	Vis NF-E27-180 M8X10	Schraube NF-E27-180 M8X10	1		
30	Water pump pulley kit 115/230V	Kit poulie pompe à eau 115/230V	115/230V Wasserpumperolle Satz	1	310004669	S
	Water pump pulley kit 400V	Kit poulie pompe à eau 400V	400V Wasserpumperolle Satz	1	310004883	S
	Water pump pulley	Poulie pompe à eau	Wasserpumperolle	1		
31	Blade shaft pulley kit 115/230V	Kit poulie arbre de meule 115/230V	115/230V Schleifachserolle Satz	1	310004779	S
	Blade shaft pulley kit 400V	Kit poulie arbre de meule 400V	400V Schleifachserolle Satz	1	310004888	S
	Blade shaft pulley	Poulie arbre de meule	Schleifachserolle	1		
	Screw NF-E27-180 M8X10	Vis NF-E27-180 M8X10	Schraube NF-E27-180 M8X10	1		
32	Bearing protection kit	Kit protection paliers	Lagerschutz Satz	1	310004792	S
	Sheet of protection	Tôle de protection	Schützblech	1		
	screw DIN 933 - M8X22	vis DIN 933 - M8X22	Schraube DIN 933 - M8X22	4		
	washer DIN 125 - A8,4	rondelle DIN 125 - A8,4	Scheibe DIN 125 - A8,4	4		
33	Belt tensioner kit	Kit tendeur de courroies	Antriebsriemenspanner Satz	1	310007386	S
	screw DIN 444 - M8X45	vis DIN 444 - M8X45	Schraube DIN 444 - M8X45	2		
	screw DIN 444 - M8X30	vis DIN 444 - M8X30	Schraube DIN 444 - M8X30	2		
	screw DIN 933 - M8X40	vis DIN 933 - M8X40	Schraube DIN 933 - M8X40	2		
	screw DIN 933 - M8X30	vis DIN 933 - M8X30	Schraube DIN 933 - M8X30	2		
	washer DIN 125 - A8,4	rondelle DIN 125 - A8,4	Scheibe DIN 125 - A8,4	8		
	washer DIN 9021 - A8	rondelle DIN 9021 - A8	Scheibe DIN 9021 - A8	8		
	washer DIN 128 - A8	rondelle DIN 128 - A8	Scheibe DIN 128 - A8	8		
	nut DIN 985 - M8	ecrou DIN 985 - M8	Mutter DIN 985 - M8	8		
	nut DIN 934 - M8	ecrou DIN 934 - M8	Mutter DIN 934 - M8	2		
34	Motor kit 115V	Kit moteur 115V	115V MotorSatz	1	310006949	S
	Motor kit 230V	Kit moteur 230V	230V MotorSatz	1	510003842	S
	Motor kit 400V	Kit moteur 400V	400V MotorSatz	1	310004197	S
	Motor	Moteur	Motor	1		
35	Mobile flange kit	Kit flasque mobile	Beweglicher Flansche Satz	1	510111768	S
	Mobile flange	Flasque mobile	Beweglicher Flansche	1		
	Thumb screw of the flask	vis de serrage du flasque	Flansche Klemmschraube	1		
36	Blade shaft kit	Arbre de meule	Schleifscheibenachse Satz	1	310488772	S
	Blade shaft	Arbre de meule	Schleifscheibenachse	1		

Cutting head / Tête de coupe / Schüsselkopf



Depends on the serial number of the machine
 Dépend du numéro de serie de la machine
 Hängt von der Nummer von Serie der Maschine ab

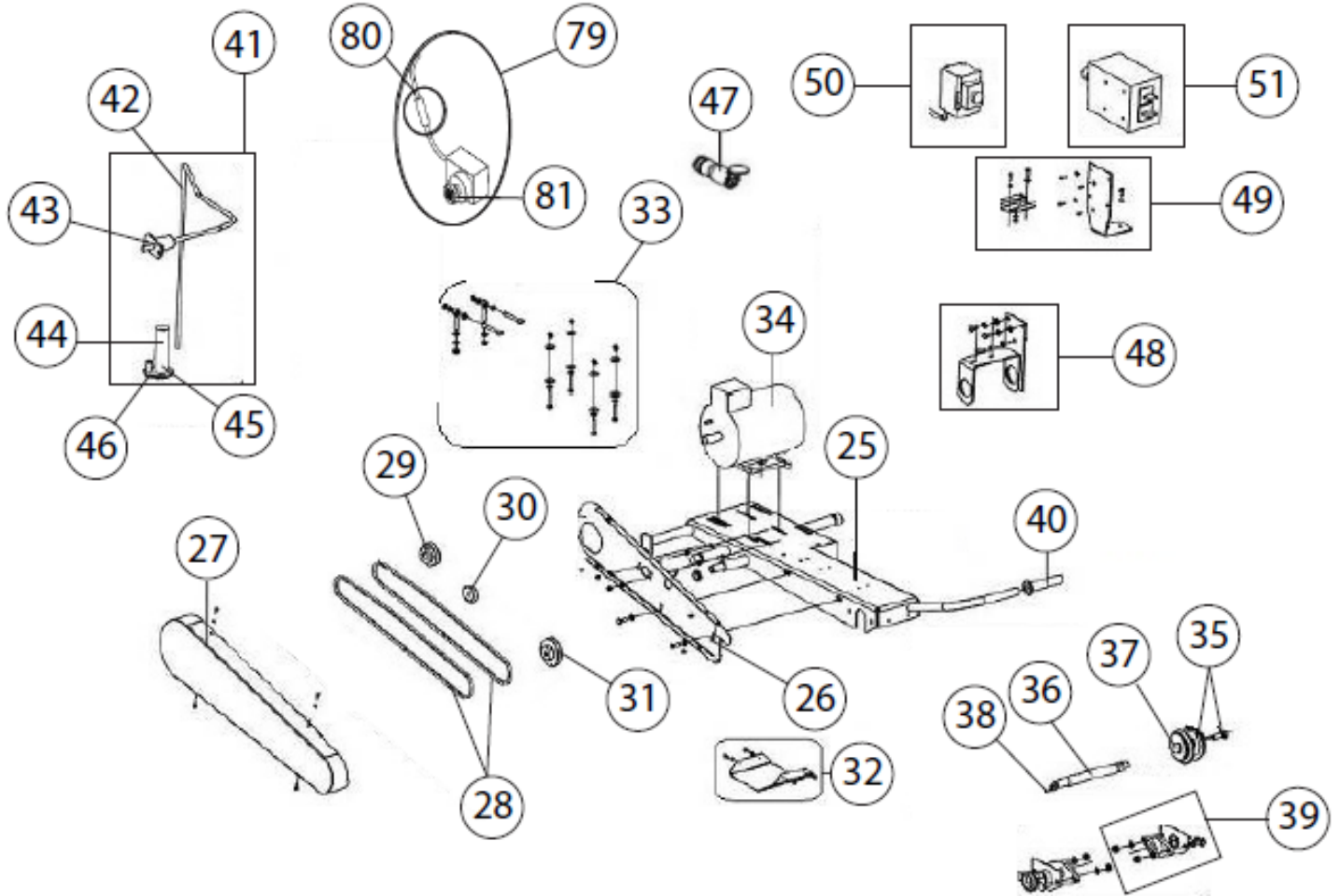

Electric case / Boitier électrique / Elektrisches Gehäuse 400 V:

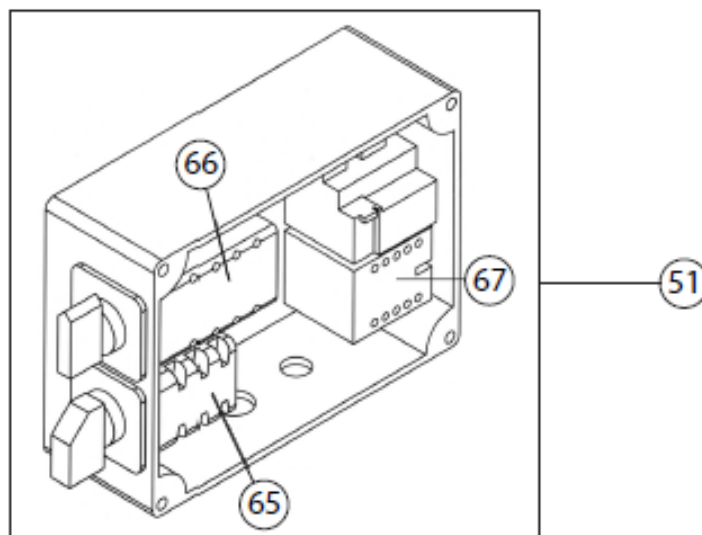
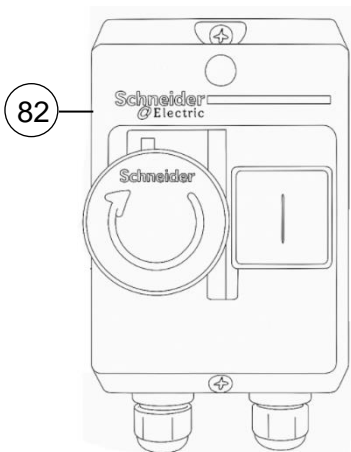

POS.	DESCRIPTION	DESCRIPTION	BESCHREIBUNG	QTY	REF	TYPE
37	Fixed flange kit	Flasque fixe	Fester Flansche Satz	1	310488773	S
	Fixed flange	Flasque fixe	Festes Lagerschild	1		
38	Blade shaft key	Clavette arbre de meule	Schleifscheibenachsekeil	1	310004431	S
	Blade shaft key	Clavette arbre de meule	Schleifscheibenachse Keil	1		
39	Bearing kit	Kit palier	Lager Satz	1	310488770	S
	Bearing	Palier	Lager	1		
	screw DIN 603 - M10X30	vis DIN 603 - M10X30	Schraube DIN 603 - M10X30	2		
	washer DIN 125 - A10,5	rondelle DIN 125 - A10,5	Scheibe DIN 125 - A10,5	4		
	washer DIN 128 - A10	rondelle DIN 128 - A10	Scheibe DIN 128 - A10	2		
	nut DIN 985 - M10	ecrou DIN 985 - M10	Mutter DIN 985 - M10	2		
40	Rubber handle kit	Poignée en caoutchouc	Gummigriff Satz	1	310004190	S
	Rubber handle	Poignée en caoutchouc	Gummigriff	1		
41	Water pump assy. Kit (up to 161000000)	Kit pompe à eau complète (jusqu'à 161000000)	Kompletter Wasserpumpe Satz	1	310004436	S
	Water pump	Pompe à eau	Wasserpumpe	1		
	screw ISO 7380 - M5X20	vis ISO 7380 - M5X20	Schraube ISO 7380 - M5X20	2		
	washer DIN 125 - A5,3	rondelle DIN 125 - A5,3	Scheibe DIN 125 - A5,3	4		
	washer DIN 128 - A5	rondelle DIN 128 - A5	Scheibe DIN 128 - A5	2		
	nut DIN 985 - M5	ecrou DIN 985 - M5	Mutter DIN 985 - M5	2		
79	Water pump assy. 115V kit (from 161000000)	Kit pompe complète 115V (depuis 161000000)	Wasserpumpe Satz 115V (Serien Nr. von 161000000)	1	310459733	S
	Water pump assy. 230V kit (from 161000000)	Kit pompe complète 230V (depuis 161000000)	Wasserpumpe Satz 230V (Serien Nr. von 161000000)	1	310446803	S
	Male connector	Connecteur mâle	Stecker (männlich.)	1		
	Female connector	Connecteur femelle	Stecker (Weiblich.)	1		
	Water pump 220V	Pompe complète 220V	Wasserpumpe Kompl.	1		
80	Powersafe Plug	Connecteur électrique étanche	Wasserdichte Steckverbindung	1	510109120	S
	Male connector	Connecteur mâle	Stecker (männlich.)	1		
	Female connector	Connecteur femelle	Stecker (Weiblich.)	1		
81	Sieve of water pump	Tamis de pompe à eau	Wasserpumpesieb	1	310007222	S
42	Sheath of pump kit	Kit Gaine de pompe	Pumpenhülle Satz	1	310004232	S
43	Head of water pump Kit	Kit Tête de pompe à eau	Wasserpumpe Kopf Satz	1	310004236	S
44	Pump housing kit	Kit Corps de pompe	Pumpegehäuse Satz	1	310004231	S
45	Propeller pump water kit	Kit Hélice pompe à eau	Wasserpumpe Propeller Satz	1	310004349	S
46	Sieve in figure pump water kit	Kit tamis en plastique pompe à eau	Wasserpumpe Kunststoffsieb Satz	1	310004207	S
47	Electrical plug kit 115V	Kit prise femelle 115V	115V Steckdose Satz (weibliches Teil)	1	310002091	S
	Electrical plug kit 230V	Kit prise femelle 230V	230V Steckdose Satz (weibliches Teil)	1	310004392	S
	Electrical plug kit 400V	Kit prise femelle 400V	400V Steckdose Satz (weibliches Teil)	1	310004160	S
	Electrical plug	Prise femelle	Steckdose (weibliches Teil)	1		
48	Aligning support kit	Kit support auto alignant	Parallelführungsarm Satz	1	310004794	S
	Aligning support	Support auto alignant	Parallelführungsarm	1		
	screw DIN 933 - M8X20	vis DIN 933 - M8X20	Schraube DIN 933 - M8X20	3		
	washer DIN 128 - A8	rondelle DIN 128 - A8	Scheibe DIN 128 - A8	3		
49	Switch support kit 115V	Kit Support interrupteur 115V	115V Schalterträger Satz	1	310004432	S
	Switch support kit 230V	Kit Support interrupteur 230V	230V Schalterträger Satz	1	310005069	S
	Switch support kit 400V	Kit Support interrupteur 400V	400V Schalterträger Satz	1	310007388	S
	Switch support	Support interrupteur	Schalterträger	1		
50	screw DIN 933 - M8X15	vis DIN 933 - M8X15	Schraube DIN 933 - M8X15	2		
	washer DIN 125 - A8,4	rondelle DIN 125 - A8,4	Scheibe DIN 125 - A8,4	5		
	nut DIN 985 - M8	ecrou DIN 985 - M8	Mutter DIN 985 - M8	2		
	Switch kit 115V	Kit interrupteur 115V	115V Schalter Satz	1	310006864	S
	Switch kit 230V	Kit interrupteur 230V	230V Schalter Satz	1	310004332	S
	Switch	Interrupteur	Schalter	1		
51	screw DIN 7958 - M4X20	vis DIN 7958 - M4X20	Schraube DIN 7958 - M4X20	2		
	screw DIN 7958 - M4X50	vis DIN 7958 - M4X50	Schraube DIN 7958 - M4X50	2		
	washer DIN 125 - A4,3	rondelle DIN 125 - A4,3	Scheibe DIN 125 - A4,3	2		
	washer DIN 128 - A4	rondelle DIN 128 - A4	Scheibe DIN 128 - A4	2		
	nut DIN 985 - M4	ecrou DIN 985 - M4	Mutter DIN 985 - M4	2		
	Delta-Star Merz Switch kit 400V	Kit interrupteur-étoile triangle Merz 400V	400V-Merz Stern dreieckdschalter Satz	1	310005684	S
	Switch	Interrupteur	Schalter	1		
	screw DIN 933 - M5X20	vis DIN 933 - M5X20	Schraube DIN 933 - M5X20	4		
	nut DIN EN ISO 7040 - M5 - N	ecrou DIN EN ISO 7040 - M5 - N	Mutter DIN EN ISO 7040 - M5 - N	4		
	washer DIN 125 - A 5.3	rondelle DIN 125 - A 5.3	Scheibe DIN 125 - A 5.3	8		
65	Section switch kit - 400V	Sectionneur	400V Hauptschalter	1	310006622	S
66	Star triangle switch kit - 400V	Kit Interrupteur étoile triangle 400V	400V Stern dreieckdschalter Satz	1	310006618	S
67	Relay kit - 400V	Kit relais	400V Relais Satz	1	310006617	S
82	Schneider Switch 400V	Interrupteur Schneider 400V	400V-Schneider Schalter	1	310628898	S
	Switch 400V	Interrupteur 400V	400V Schalter	1		
	Switch support	Support interrupteur	Schalterträger	1		
	Countersunk head screw DIN 7991 - M6x20	Vis à tête fraisée DIN 7991 - M6x20	Senkkopfschraube DIN 7991 - M6x20	2		
	Washer DIN 125 - M6	Rondelle DIN 125 - M6	Scheibe DIN 125 - M6	2		
	Nut DIN 7040 - M6	Écrou DIN 7040 - M6	Mutter DIN 7040 - M6	2		

Blade guard / Carter de disque / Plattegehäuse

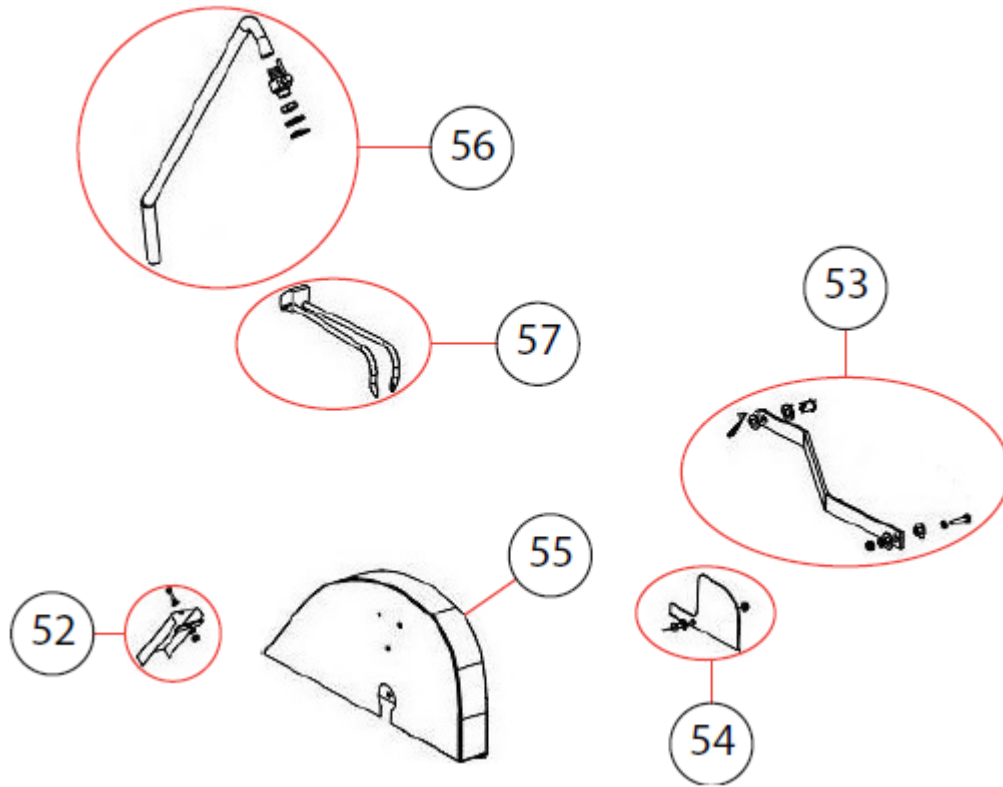

POS.	DESCRIPTION	DESCRIPTION	BESCHREIBUNG	QTY	REF	TYPE
52	Splash guard kit	Kit bavette	Spritzschutzklappen Satz	1	310004413	W
	Splash guard	Bavette	Spritzschutzklappen	1		
	screw ISO 7380 - M8X20	vis ISO 7380 - M8X20	Schraube ISO 7380 - M8X20	1		
	washer DIN 125 - A6,4	rondelle DIN 125 - A6,4	Scheibe DIN 125 - A6,4	2		
	washer DIN 128 - A6	rondelle DIN 128 - A6	Scheibe DIN 128 - A6	1		
	nut DIN 985 - M6	ecrou DIN 985 - M6	Mutter DIN 985 - M6	1		
53	Pivoting arm kit	Kit bras de renvoi	Hebelarm Satz	1	310488021	S
	Pivoting arm	Bras de renvoi	Hebelarm	1		
	screw DIN 933 - M8X30	vis DIN 933 - M8X30	Schraube DIN 933 - M8X30	1		
	washer DIN 125 - A8,4	rondelle DIN 125 - A8,4	Scheibe DIN 125 - A8,4	2		
	washer DIN 137 - A8	rondelle DIN 137 - A8	Scheibe DIN 137 - A8	1		
	nut DIN 985 - M8	ecrou DIN 985 - M8	Mutter DIN 985 - M8	1		
54	Blade guard cover kit	Kit fermeture carter de disque	Verschluss Scheibenschutz Satz	1	310004790	W
	Blade guard cover	Tôle fermeture carter de disque	Verschluss Scheibenschutzblech	1		
	screw DIN 933 - M8X25	vis DIN 933 - M8X25	Schraube DIN 933 - M8X25	1		
	washer DIN 125 - A8,4	rondelle DIN 125 - A8,4	Scheibe DIN 125 - A8,4	2		
	nut DIN 985 - M8	ecrou DIN 985 - M8	Mutter DIN 985 - M8	1		
55	Blade guard kit	Kit carter de disque	Scheibenschutz Satz	1	310487376	S
	Blade guard	Carter de disque	Scheibenschutz	1		
56	Tap and pipe kit	Kit robinet et tuyau	HahnSatz und Wasserschlauch	1	310488775	S
	Tap	Robinet	Hahn	1		
	Pipe	Tuyau	Schlauch	1		
57	Nozzle kit	Busette	Düsen Satz	1	310488774	S
	Nozzle	Busette	Düsen	1		

Table / Table / Tisch

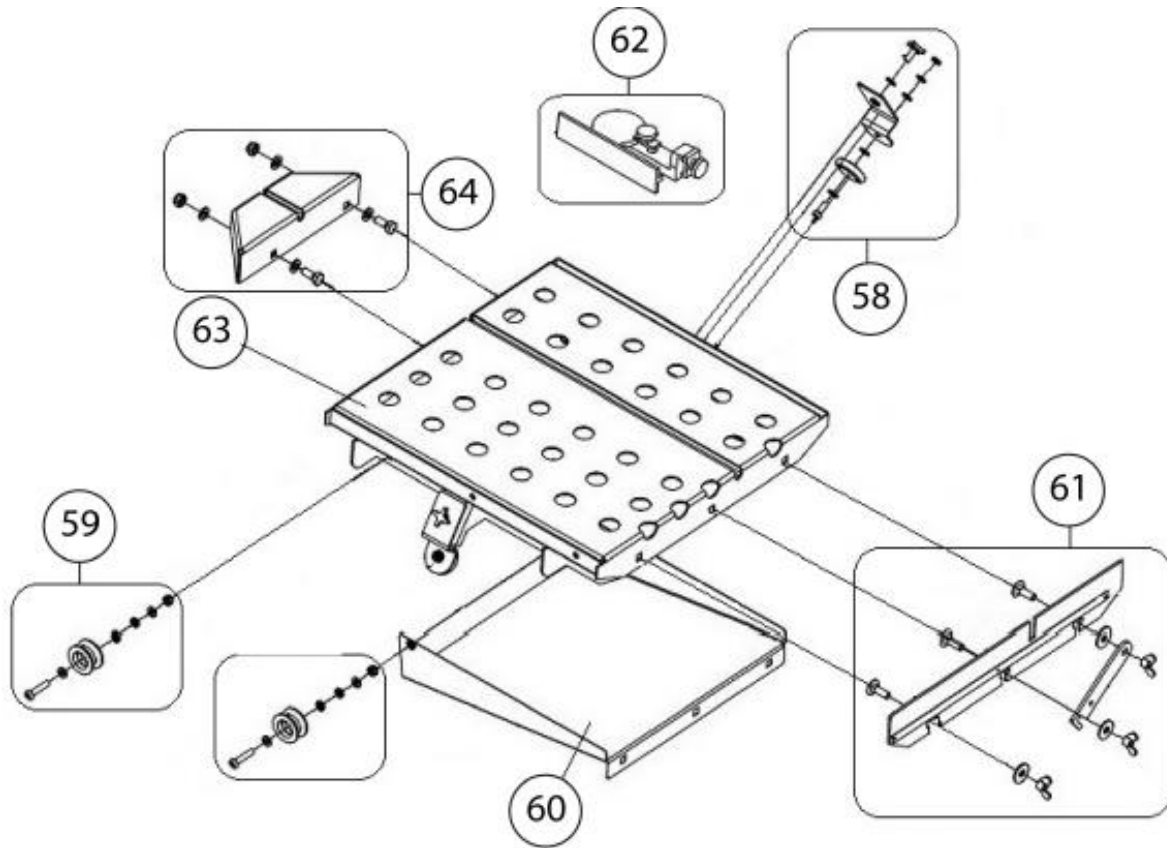

POS.	DESCRIPTION	DESCRIPTION	BESCHREIBUNG	QTY	REF	TYPE
58	Anti-tilting kit	Système anti-basculement	Stabilisierungssystem	1	310487377	S
	Anti-swing sheet	Plaque anti-basculement	Stabilisierungsblech	1		
	screw ISO 7380 - M8X30	vis ISO 7380 - M8X30	Schraube ISO 7380 - M8X30	1		
	washer DIN 125 - A8,4	rondelle DIN 125 - A8,4	Scheibe DIN 125 - A8,4	4		
	washer DIN 128 - A8	rondelle DIN 128 - A8	Scheibe DIN 128 - A8	1		
	nut DIN 985 - M8	ecrou DIN 985 - M8	Mutter DIN 985 - M8	1		
59	Wheels kit (X 4)	Kit de roulettes (X 4)	Rolle Satz (X 4)	4	310007312	S
	Wheel	Roulette	Rolle	4		
	Long bushing	Douille longue	Lange Buchse	2		
	Short bushing	Douille courte	Kurze Buchse	2		
	screw DIN 931 - M10X80	vis DIN 931 - M10X80	Schraube DIN 931 - M10X80	4		
	washer DIN 125 - A10,5	rondelle DIN 125 - A10,5	Scheibe DIN 125 - A10,5	12		
	washer DIN 128 - A10	rondelle DIN 128 - A10	Scheibe DIN 128 - A10	4		
	nut DIN 985 - M10	ecrou DIN 985 - M10	Mutter DIN 985 - M10	4		
60	Water recuperator	Récupérateur d'eau	Wassersammler	1	310007313	S
61	Material stop kit	Kit butée de matériau	Baustoff Anschlag Satz	1	510112498	S
	Material stop	Butée de matériau	Baustoff Anschlag	1		
	screw DIN 603 - M10X25	vis DIN 603 - M10X25	Schraube DIN 603 - M10X25	3		
	washer DIN 9021 - A10,5	rondelle DIN 9021 - A10,5	Scheibe DIN 9021 - A10,5	3		
	nut DIN 315 - M10	ecrou DIN 315 - M10	Mutter DIN 315 - M10	3		
62	Angular cutting-guide kit	Guide de coupe angulaire	Winkelfräserführung Satz	1	310064856	S
	Angular cutting-guide	Guide de coupe angulaire	Winkelfräserführung	1		
63	Table kit	Kit table	Tisch Satz	1	510112497	S
64	600mm table extension kit	Kit rallonge 600mm	600mm Ausziehplatte Satz	1	310007311	S
	600mm table extension	Rallonge 600mm	600mm Ausziehplatte	1		
	screw DIN 933 - M10X30	vis DIN 933 - M10X30	Schraube DIN 933 - M10X30	2		
	washer DIN 125 - A10,5	rondelle DIN 125 - A10,5	Scheibe DIN 125 - A10,5	4		
	nut DIN 985 - M10	ecrou DIN 985 - M10	Mutter DIN 985 - M10	2		

115-230V Motor:

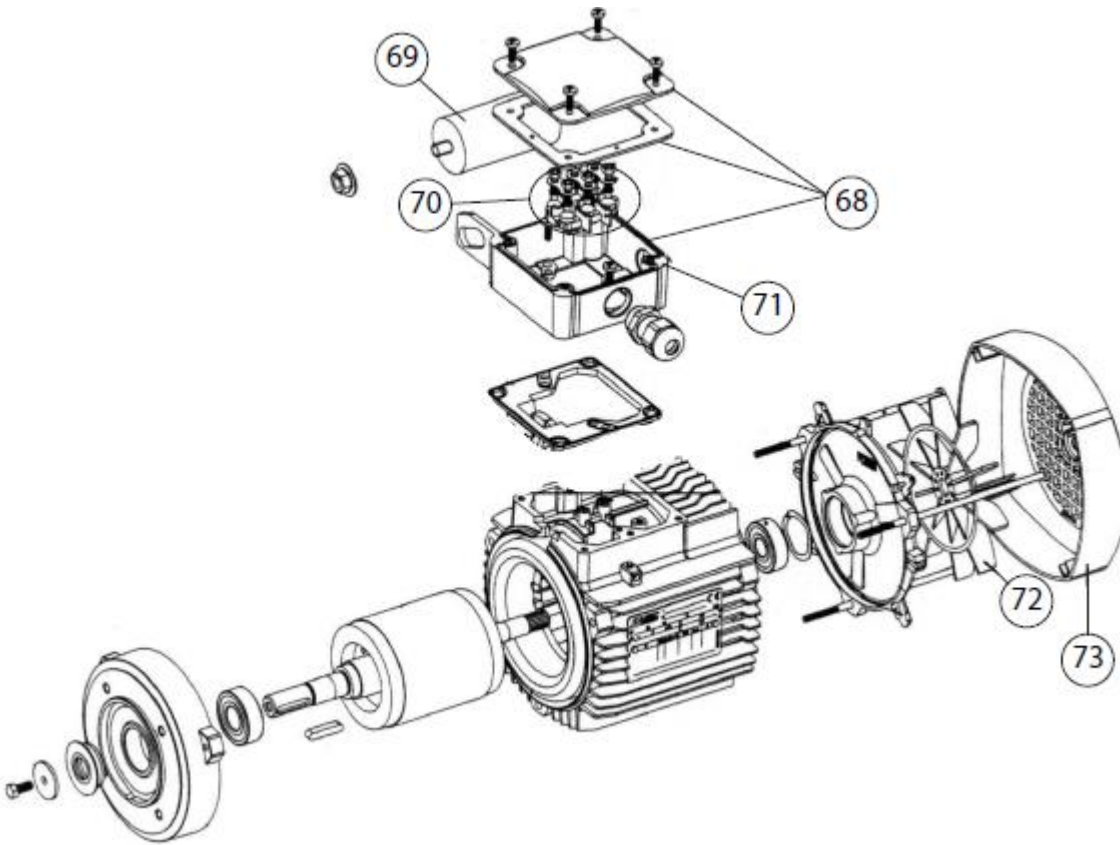

400V Motor:

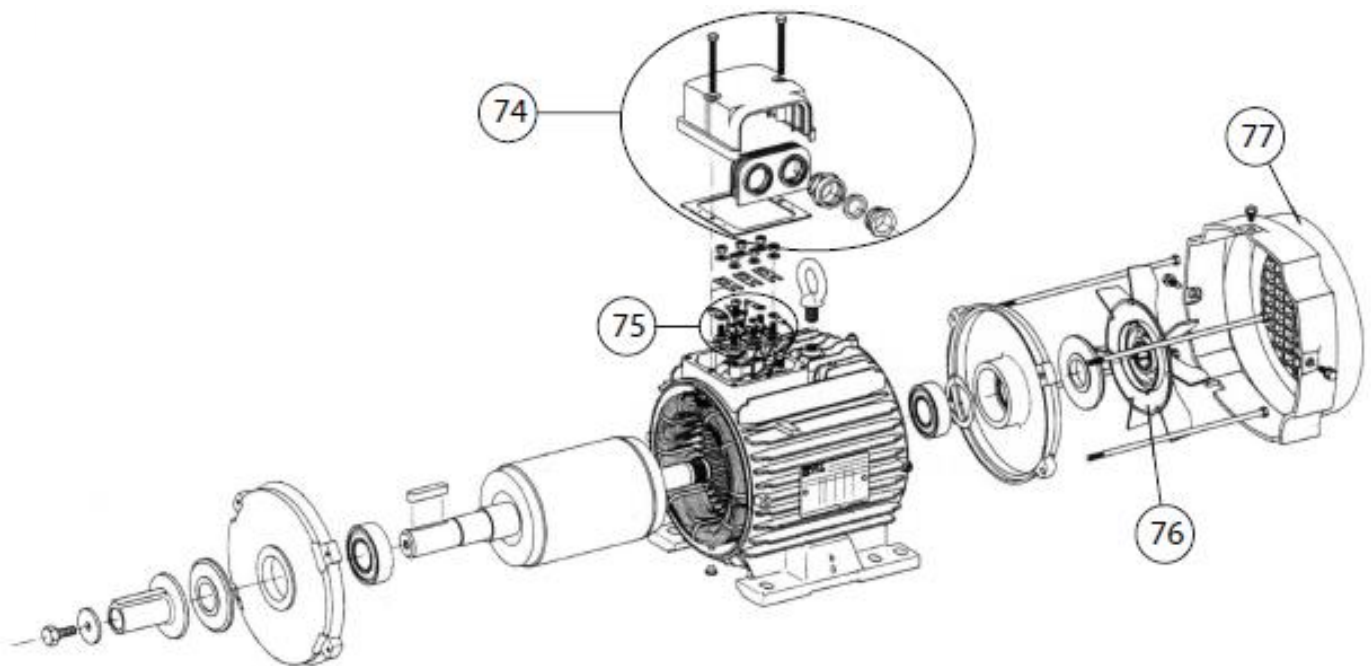

115-230V Motor Leroy:

POS.	DESCRIPTION	DESCRIPTION	BESCHREIBUNG	QTY	REF	TYPE
68	Kit limps on terminals - 115/230V	Kit boîte à bornes - 115/230V	115/230V Anschlusskasten Satz	1	310004243	S
69	Condenser kit - 115/230V	Kit condensateur - 115/230V	115/230V Kondensator Satz	1	310004329	S
70	Terminal kit - 115/230V	Kit Bornier - 115/230V	115/230V Terminal Satz	1	310004248	S
71	Thermal protection kit - 115 V	Kit Protection thermique - 115 V	115 V Wärmeschutz Satz	1	310006961	S
	Thermal protection kit - 230 V	Kit Protection thermique - 230 V	230 V Wärmeschutz Satz	1	310005068	S
72	Ventilator kit - 115/230V	Kit ventilateur - 115/230V	115/230V Ventilator Satz	1	310004240	S
73	Ventilator cap kit - 115/230V	Kit capot ventilateur - 115/230V	115/230V Ventilatorshaube Satz	1	310004239	S

230 V Motor Able:

POS.	DESCRIPTION	DESCRIPTION	BESCHREIBUNG	QTY	REF	TYPE
68	Connecting box MOTOR ABLE	Boite à bornes MOTEUR ABLE	Klemmenblock MOTOR ABLE (Serien Num bis 1611....)	1	510133165	S
72	Motor fan MOTOR ABLE	Ventilateur moteur MOTEUR ABLE	Ventilator Motor MOTOR ABLE	1	510133166	S
69	Condensator MOTEUR ABLE for dephasing only (Serial Nbr from 1611....) 1 of 80µF or 2 of 40µF in parallel	Condensateur MOTEUR ABLE pour le déphasage uniquement (N° série à partir de 1611....) 1 de 80µF ou 2 de 40µF en parallèle	Kondensator MOTEUR ABLE nur für Phasenwinkel (Serien Num bis 1611....) 1 von 80µF oder 2 von 40µF parallelaufend	1	510137240	S
73	Cover fan MOTOR ABLE	Capot ventilateur MOTEUR ABLE	Motordeckel MOTOR ABLE	1	510133168	S
	Engine feet Able	Pieds de moteurs Able	Motorfüße Able	2	310533083	S

400V Motor:

POS.	DESCRIPTION	DESCRIPTION	BESCHREIBUNG	QTY	REF	TYPE
74	Kit limps on terminals - 400 V	Kit boîte à bornes - 400 V	400V Anschlusskasten Satz	1	310004250	S
75	Terminal kit - 400 V	Kit Bornier - 400 V	400 V Terminal Satz	1	310004340	S
76	Ventilator kit - 400 V	Kit ventilateur - 400 V	400 V Ventilator Satz	1	310004249	S
77	Ventilator cap kit - 400 V	Kit capot ventilateur - 400 V	400 V Satz Ventilatorshaube Satz	1	310310272	S

Stickers / Autocollants / Aufkleber:



POS.	DESCRIPTION	DESCRIPTION	BESCHREIBUNG	QTY	REF	TYPE
78	Sticker kit	Kit d'autocollants	Aufkleber Satz	1	510131209	S
	White arrow	Flèche blanche	Weißer Pfeil	1		
	4 pictograms	4 pictogrammes	4 Piktogramme	1		
	Right side	Flanc droit	Rechte Flanke	1		
	Norton Clipper Logo Blade guard	Norton Clipper carter de disque	Norton Clipper Scheibehäuse	1		
	Risk of hand cut	Risque de coupure main	Gefahr von Schnittverletzungen	1		
	Norton Clipper Logo Blade guard back	Norton Clipper carter de disque arrière	Norton Clipper Hinterplattegehäuse	1		
	Logo 3 bands	Logo 3 bandes	3 Bänder Logo	1		

SAINT-GOBAIN ABRASIVES
INDUSTRIEWEG 21
9420 ERPE-MERE
BELGIUM
TEL: +32(0) 2 267 21 00

SAINT-GOBAIN CONSTRUCTION PRODUCTS
CZ A.S
DIVIZE ABRASIVES
SMRČKOVA 2485/4
180 00 PRAHA 8
CZECH REPUBLIC
TEL: +420 255 719 326
FAX: +420 255 719 321

SAINT-GOBAIN ABRASIVES A/S
DYBENDALSVÆNGET 2,
DK-2630 TAASTRUP
DENMARK
TEL: +45 4675 5244

PO BOX 643706
FORTUNE TOWER OFFICE 2106
JLT BLOCK C
(NEXT TO METRO STATION)
JUMEIRA LAKE TOWER, DUBAI
UNITED ARAB EMIRATES
TEL: +971 4 431 5154
FAX: +971 4 431 5434

SAINT-GOBAIN ABRASIFS
RUE DE L'AMBASSADEUR - B.P.8
78 702 CONFLANS CEDEX
FRANCE
TEL: +33 (0)1 34 90 40 00
FAX: +33 (0)1 39 19 89 56

SAINT-GOBAIN ABRASIVES GMBH
BIRKENSTRASSE 45-49
D-50389 WESSELING
GERMANY
TEL: +49 (0) 2236 703-0
FAX: +49 (0) 2236 703-730

SAINT-GOBAIN ABRASIVES KFT.
1225 BUDAPEST
BÁNYALÉG U. 60/B.
HUNGARY
TEL: +36 1 371 22 50
FAX: +36 1 371 22 55

SAINT-GOBAIN ABRASIVI S.P.A
VIA PER CESANO BOSCONI 4
I-20094 CORSICO MILANO
ITALY
TEL: +39 02 44 851
FAX: +39 02 44 78 266

SAINT-GOBAIN ABRASIVES S.A.
190 RUE J.F. KENNEDY
L-4930 BASCHARAGE
GRAND DUCHE DE LUXEMBOURG
TEL: +352 50 401 1
FAX: +331 83 717 792
NO. VERT (FRANCE): 0800 906 903

SAINT-GOBAIN ABRASIFS, S.A.
2 ALLÉE DES FIGUIERS
AIN SEBAË - CASABLANCA
MOROCCO
TEL: +212 5 22 66 57 31
FAX: +212 5 22 35 09 65

SAINT-GOBAIN ABRASIVES BV
GROENLOSEWEG 28
7151 HW EIBERGEN
P.O. BOX 10
7150 AA EIBERGEN
THE NETHERLANDS
TEL: +31 545 466466
FAX: +31 545 474605

SAINT-GOBAIN ABRASIVES AS
KARIHAUGVEIEN, 89
0186 OSLO
NORWAY
TEL: +47 63 87 06 00
FAX: +47 63 87 06 01

SAINT-GOBAIN HPM POLSKA SP. Z O.O.
UL. NORTON 1, 62-600 KOŁO
62-600 KOŁO
POLAND
TEL: +48 63 26 17 100
FAX: +48 63 27 20 401

SAINT-GOBAIN ABRASIVOS, L. DA
ZONA INDUSTRIAL DA MAIA
I-SECTOR VIII, NO. 122
APARTADO 6050
4476 - 908 MAIA
PORTUGAL
TEL: +351 229 437 940
FAX: +351 229 437 949

SAINT-GOBAIN GLASS
BUSINESS UNIT ABRASIVI
PUNCT DE LUCRU : LOC.VETIS, JUD.
SATU MARE 447355
STR. CAREIULUI 11
PARC INDUSTRIAL RENOVATIO
ROMANIA
TEL: +40 261 839 709
FAX: +40 261 839 710

SG HPM RUS
58, F. ENGELS STR.
STROENIE 2
105082 MOSCOW
RUSSIA
TEL: +74 955 408 355
FAX: +74 959 373 224

SAINT-GOBAIN
ABRASIVES (PTY) LTD
2 MONTEER ROAD
ISANDO 1600
P.O. BOX 67
SOUTH AFRICA
TEL: +27 11 961 2000
FAX: +27 11 961 2184/5

SAINT-GOBAIN ABRASIVOS, S.A.
CTRA. DE GUIPÚZCOA, KM. 7,5
E-31195 BERRIOPLANO (NAVARRA)
SPAIN
TEL: +34 948 306 000
FAX: +34 948 306 042

SAINT GOBAIN ABRASIVES AB
GÅRDSFOGDEVÄGEN 18A
168 66 BROMMA • SVERIGE
SWEDEN
TEL: +46 8 580 881 00
FAX: +46 8 580 881 30

SAINT-GOBAIN INOVATIF MALZEMELER VE
ASINDIRICI SAN. TIC. AS.
ALTAYÇEŞME MAH. ÇAMLI SOK. NO:21 ESAS
OFISPARK KAT:9 34843
MALTEPE, İSTANBUL • TURKEY
TEL: 0090-216-217 12 50
FAX: 0090-216-442 40 74

SAINT-GOBAIN ABRASIVES LTD.
UNICORN HOUSE UNIT 1, AMISON CLOSE
REDHILL BUSINESS PARK
STAFFORD ST161WB
UNITED KINGDOM
TEL: +44 1785 279 553
FAX: +44 1785 213 487



Saint-Gobain Abrasifs
190 Rue J.F. Kennedy
L-4930 Bascharage
Grand Duche de Luxembourg
Tel: +352 50 401 1
Fax: +331 83 717 792
no. vert (France) 0800 906 903

www.nortonabrasives.com/fr-fr